

Wooden Love Seat

416/5989

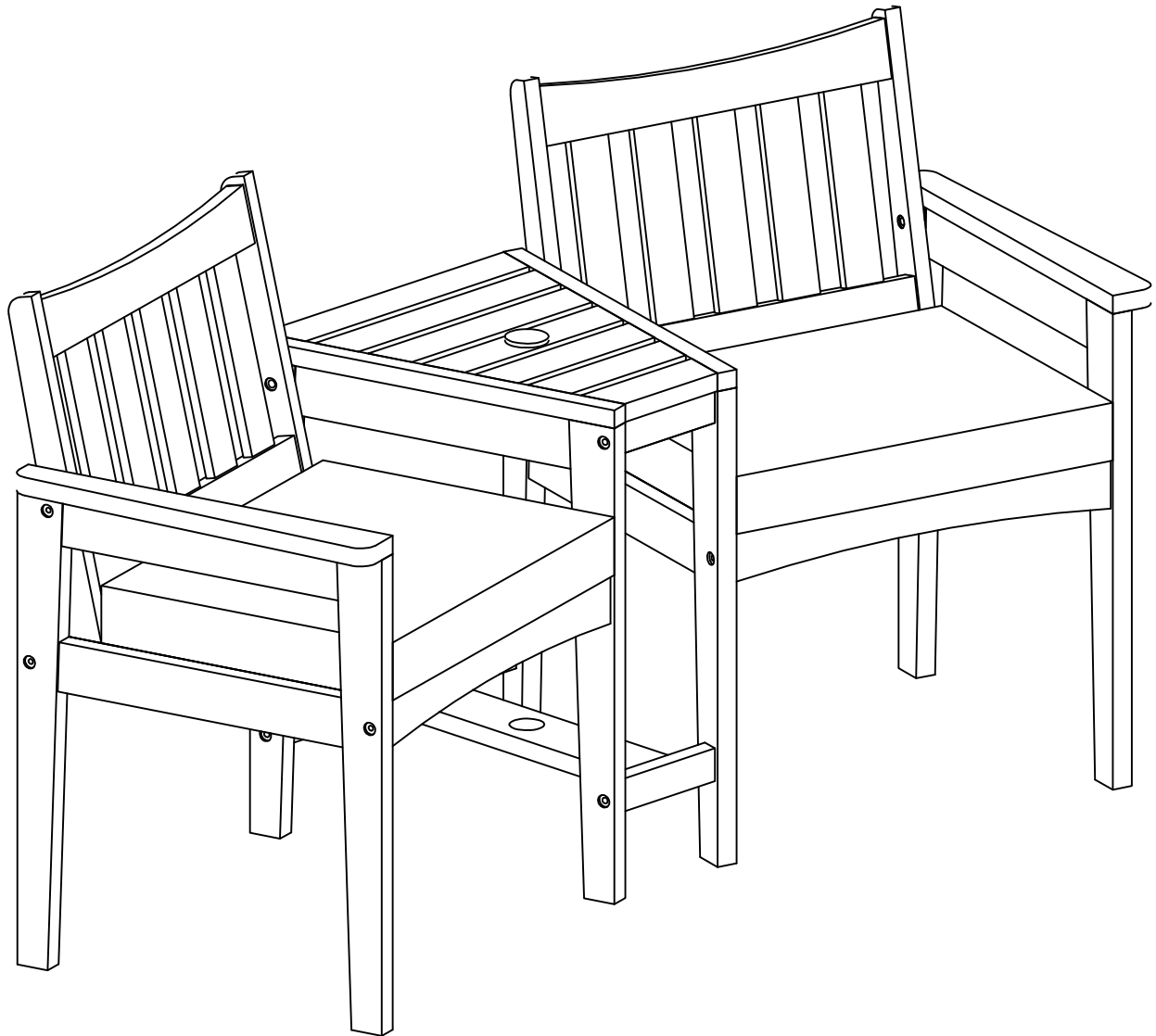

Spare Parts

Visit: www.argos-support.co.uk

Email: Help@ClickSpares.co.uk

Call: 0370 112 1928

Customer Support

Call: 0345 640 0800



Safety and Care Advice

Product Details

416/5989

IMPORTANT, RETAIN FOR FUTURE REFERENCE: READ CAREFULLY.

- Keep children and animals away from the work area, small parts could choke if swallowed.
- Make sure you have enough space to layout the parts before starting.
- This product has been constructed to be used in the domestic environment only and not for commercial purposes.

- Assemble the item as close to its final position (in the same room) as possible.
- Assemble on a soft level surface to avoid damaging the unit or your floor.

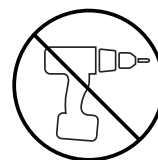

- We do not recommend the use of power drill/drivers for inserting screws as this could damage the unit. Only use hand screwdrivers.
- Parts of the assembly will be easier with 2 people.
- Dispose of all packaging carefully and responsibly .

Care and maintenance

- Only clean using a damp cloth and mild detergent. Do not use abrasive cleaners.
- Use a dry cloth to clean the product, furniture polish is not recommended.
- From time to time check that there are no loose screws, nuts or bolts. If there are please re-tighten.
- This product should not be discarded with household waste. Take to your local authority waste disposal centre.

Additional Guidance

- Assemble all parts and bolts loosely during assembly, only once the product is complete should you fully tighten the bolts.
- Regularly check and ensure that all bolts and fittings are tightend properly.
- This product is compliant EN 581

Sainsbury's Argos is a trading name of both: Argos Limited, Registered office: 489-499 Avebury Boulevard, Milton Keynes, United Kingdom, MK9 2NW, registered number: 01081551 (England and Wales); and Sainsbury's Supermarkets Limited, Registered office: 33 Holborn, London, EC1N 2HT, registered number: 03261722 (England and Wales). Both companies are subsidiaries of J Sainsbury's plc.

Fittings

Bag 1

A

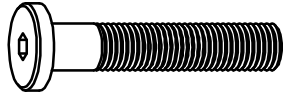

(M6x35mm) Bolt x 4Pcs

B

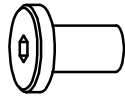

(Ø6 x 15mm) Barrel Nuts x 4Pcs

C



(M6 x 70mm) Screw x 10Pcs

D

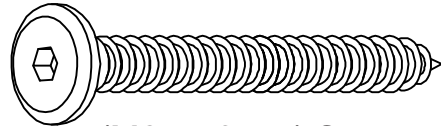

(M6 x 50mm) Screw x 15Pcs

E

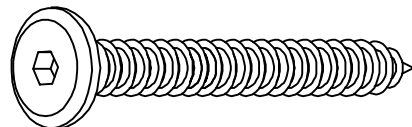

(M6 x 30mm) Screw x 8Pcs

F

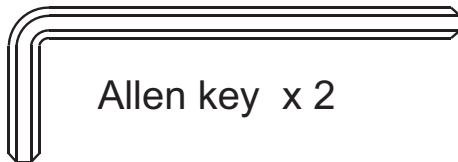

Allen key x 2

Panels

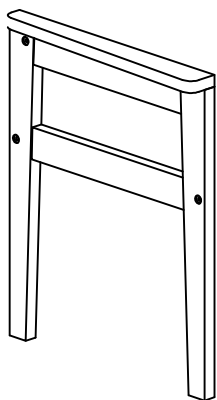

1 Left leg frame x 1

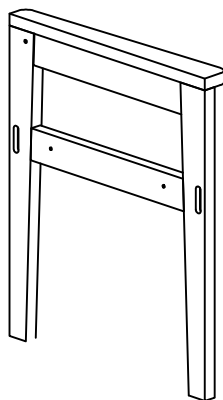

2 Right leg frame x 1

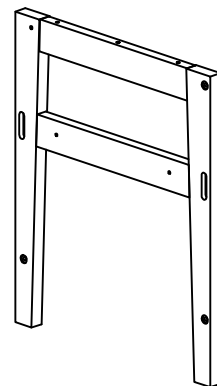

3 Left leg frame x 1

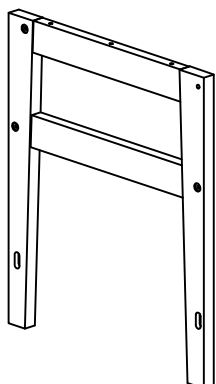

4 Right leg frame x 1

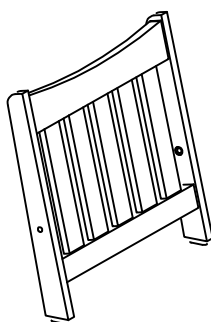

5 Backrest x 2

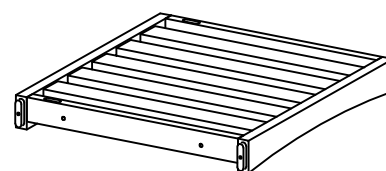

6 Seat x 2

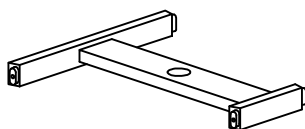

7 Leg stretchers x 1

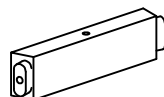

8 Leg stretchers x 1

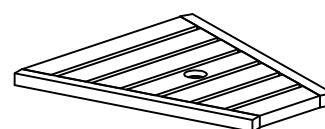

9 Table top x 1



10 Parasol hole cap x 1

Assembly Instructions

1

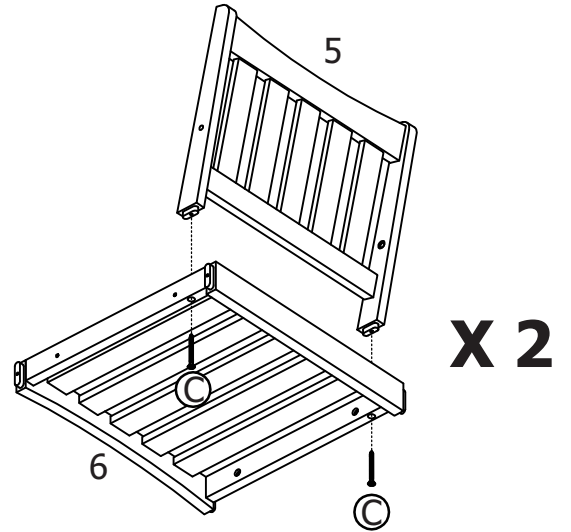
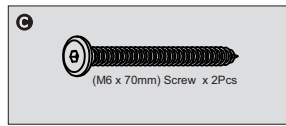
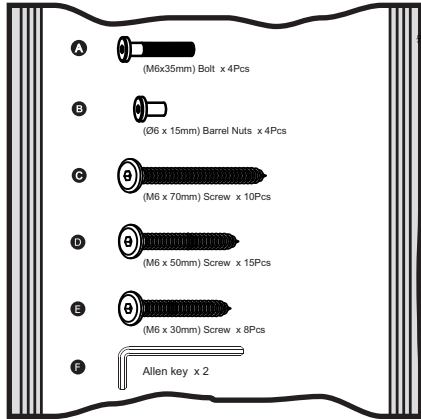

2

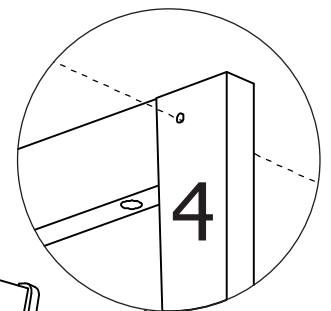
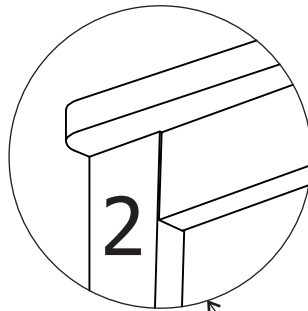
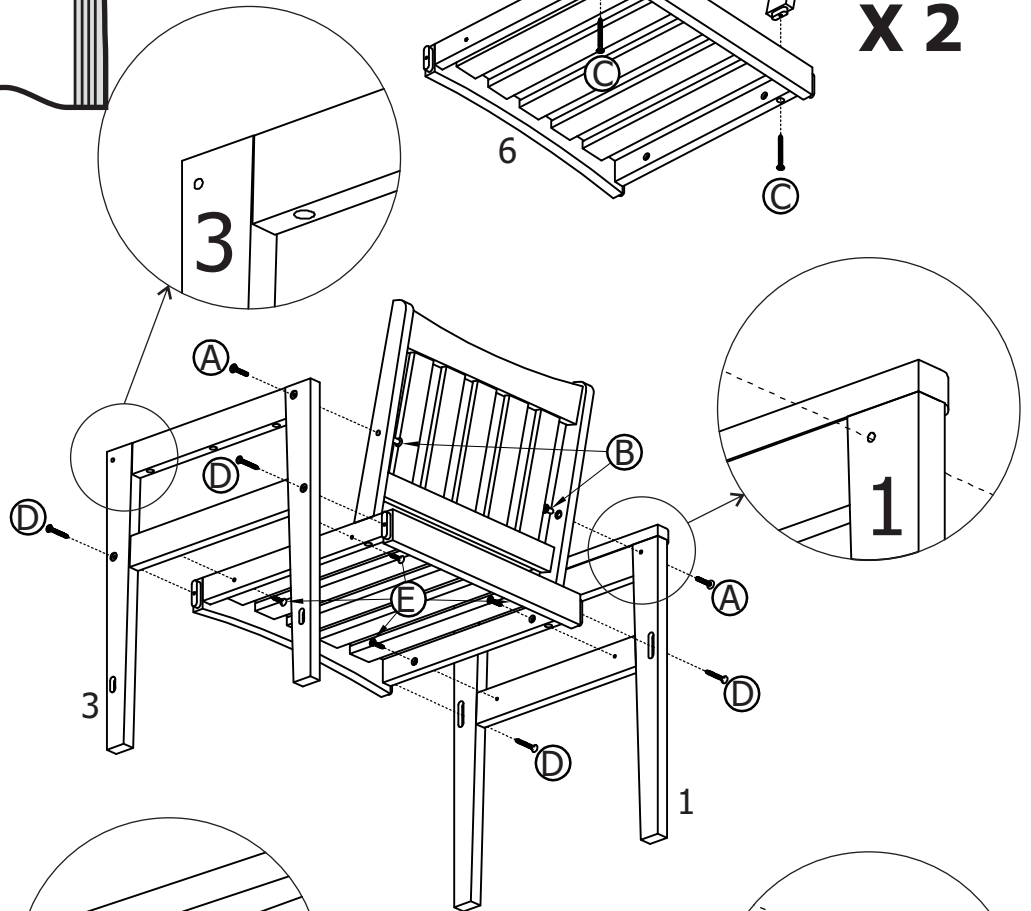
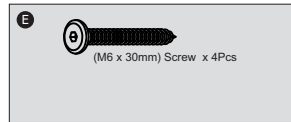
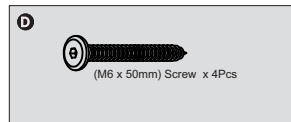
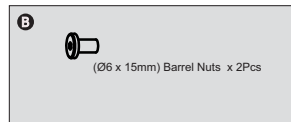
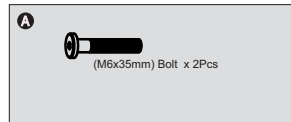

3

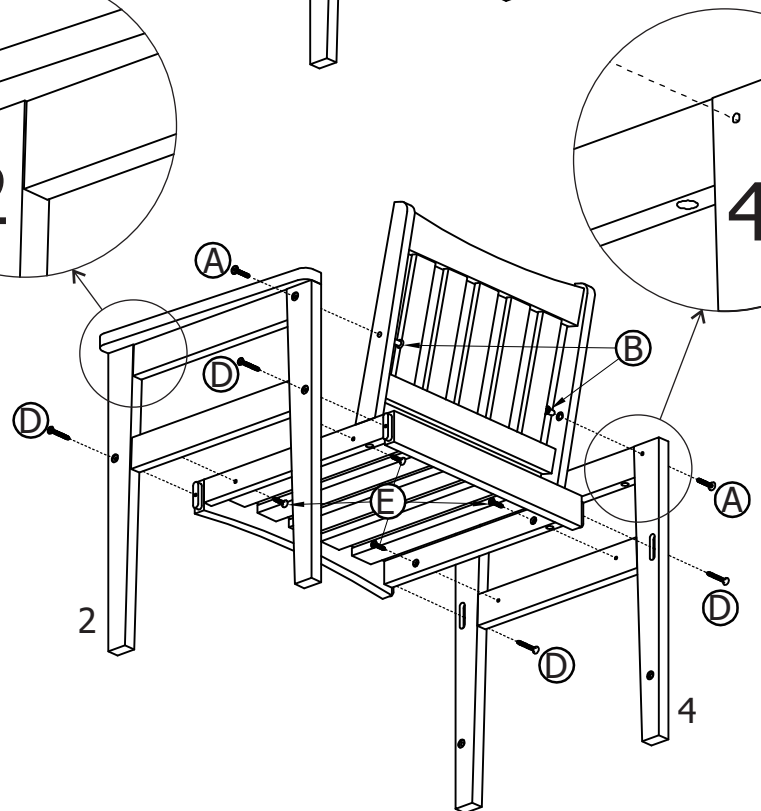
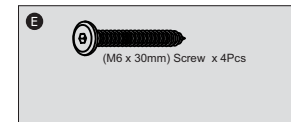
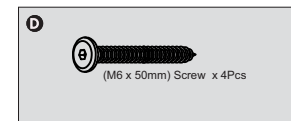
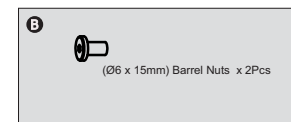
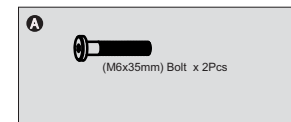

Assembly Instructions

4

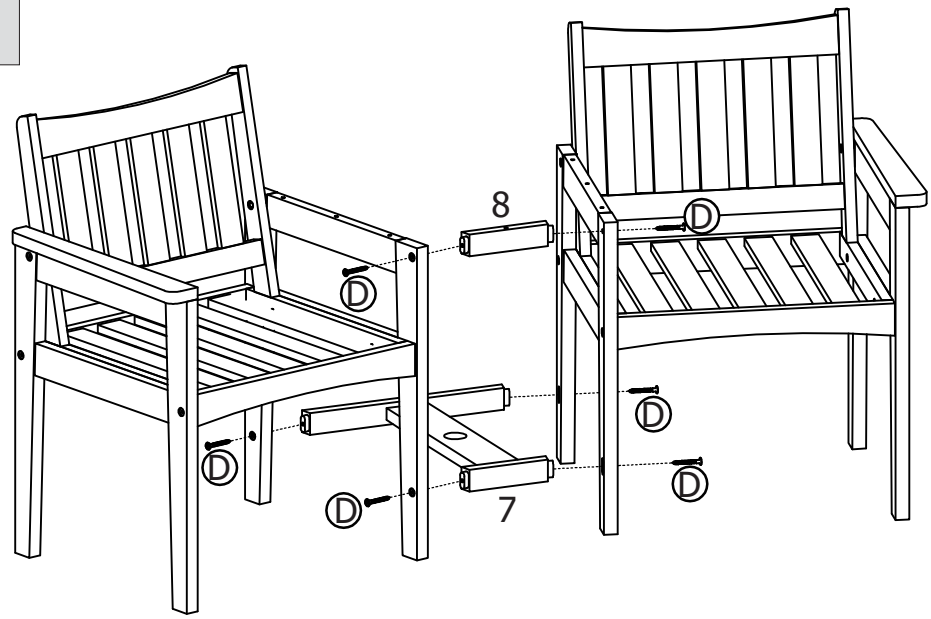
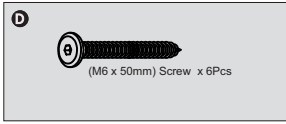

5

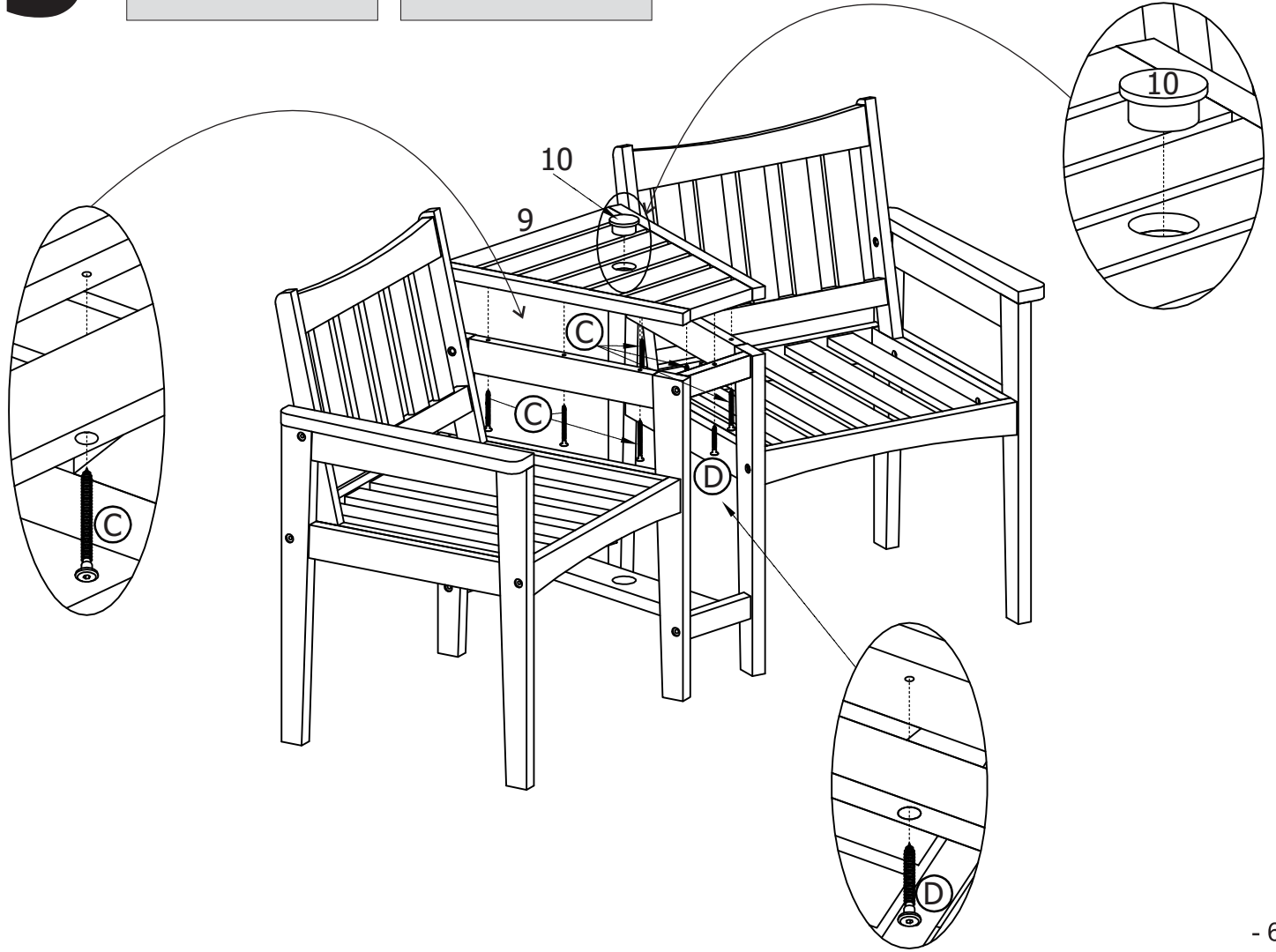
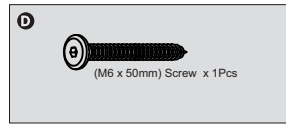
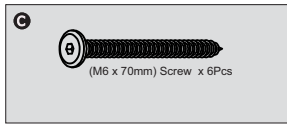

Assembly Instructions

6

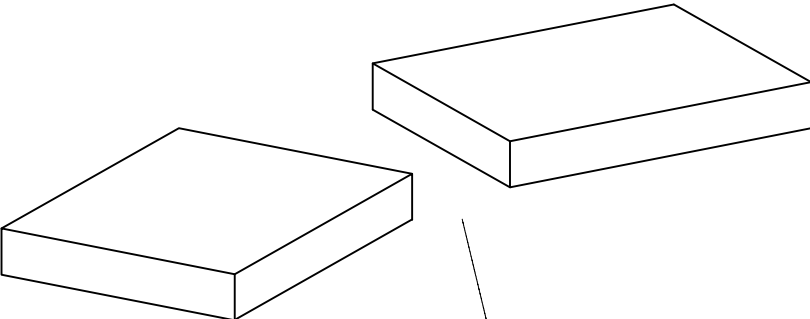
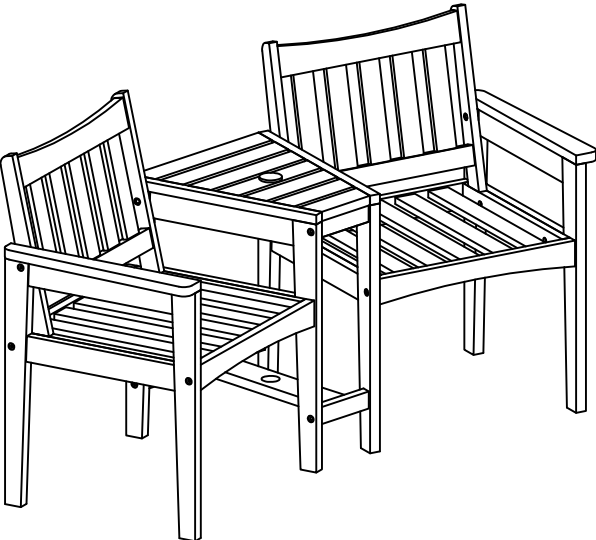

7

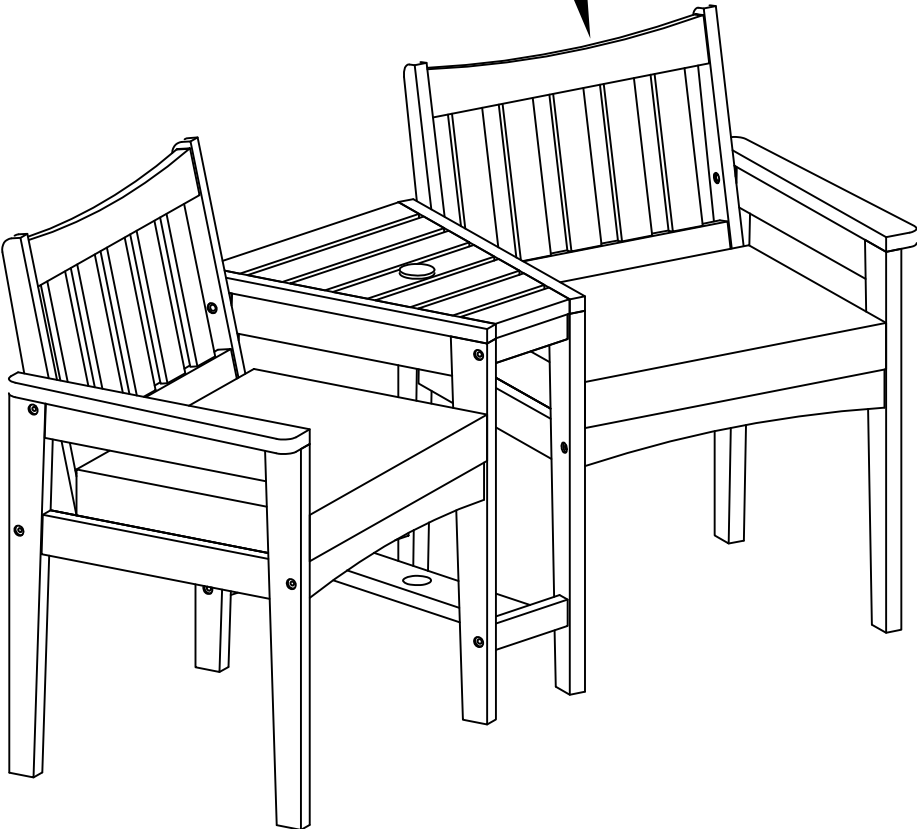

Your 1 Year Guarantee

Peace Of Mind

Knowing Your Furniture Is Protected

Protection received within the Manufacturer's Guarantee	Optional Added Protection with Furniture Care
Covers you for manufacturing defects for 1 year.	Covers you for up to 2 years for specific structural defects following the expiry of the manufacturer's guarantee.
In the event of a problem within this time please call 0345 640 0800 , or visit an Argos store. Please retain your receipt and order number as proof of purchase.	Plus - covers you for accidental damage up to 3 years for incidents such as household spills, rips, tears and burns. Accidental damage cover begins from the moment your plan starts.
	If you want to purchase Furniture Care visit https://argos.productaftercare.co.uk or go into an Argos store.

Key exclusions applying to both the Manufacturer's Guarantee and Furniture Care include where the fault is due to misuse, abuse, deliberate damage, wear and tear, neglect, use in contravention with the instructions, or if the product has been the subject of unauthorised alterations or commercial use (for full list of exclusions please visit **<https://argos.productaftercare.co.uk>** or visit an Argos store for more information).
You have up to 45 days post purchase to take out Furniture Care.
Terms and conditions apply. Your statutory rights remain unaffected.

Register

For Your Manufacturer's Guarantee

Thank you for choosing Argos Home.
We hope you love your shiny new things!

To provide you with the best possible after sales service, don't forget to visit **<https://argos.productaftercare.co.uk>** where you can **register** for your guarantee.

Once you've registered, you can upload your receipt to store safely online, alongside details of our after sales support service, ready at hand should you need it.

You can also take out Furniture Care which protects you against accidental damage, from the moment you take the plan out, to keep your new furniture looking newer for longer.

Register Today

<https://argos.productaftercare.co.uk>