

Solid pine 4 Tier shoe rack

Assembly Instructions - Please keep for future reference

391/6782

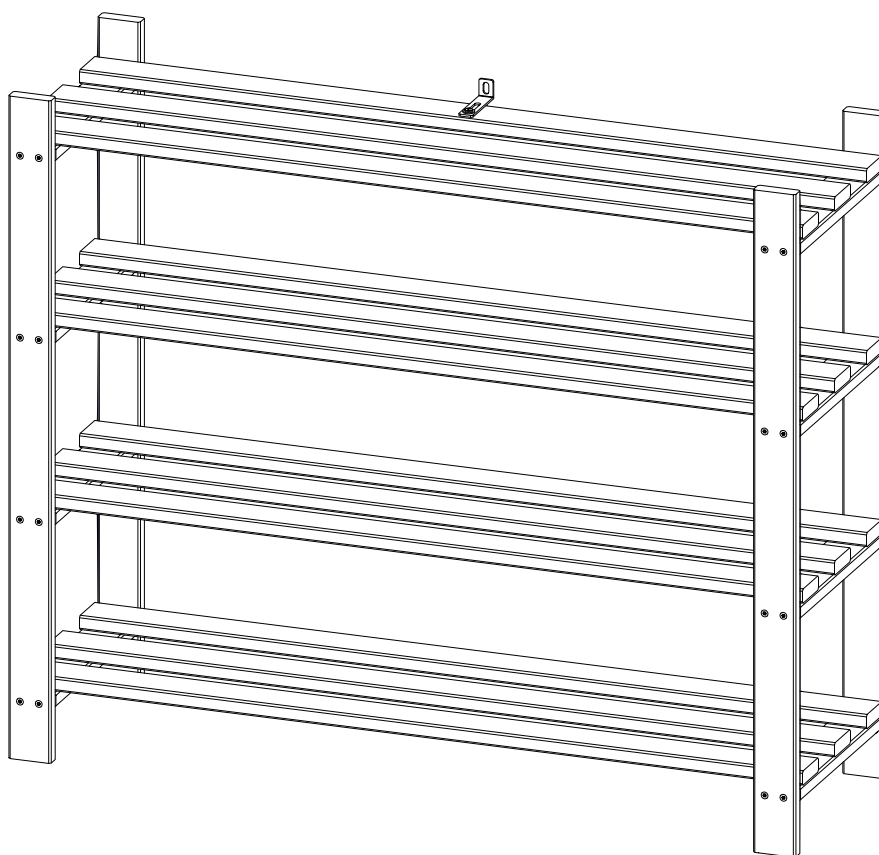

Dimensions

Width - 83.7cm
Depth - 26.6cm
Height - 69.9cm

Important – Please read these instructions fully before starting assembly

If you need help or have damaged or missing parts, call the **Customer Helpline: 08456 400 800**



Safety and Care Advice

Important – Please read these instructions fully before starting assembly

- Check you have all the components and tools listed on pages 2 and 3.
- Remove all fittings from the plastic bags and separate them into their groups.
- Keep children and animals away from the work area, small parts could choke if swallowed.
- Make sure you have enough space to layout the parts before starting.

- Do not stand or put weight on the product, this could cause damage.
- Assemble the item as close to its final position (in the same room) as possible.
- Assemble on a soft level surface to avoid damaging the unit or your floor.
- Parts of the assembly will be easier with 2 people.



- We do not recommend the use of power drill/drivers **for inserting screws**, as this could damage the unit. Only use hand screwdrivers.
- Dispose of all packaging carefully and responsibly.

Care and maintenance

- Only clean using a damp cloth and mild detergent, do not use bleach or abrasive cleaners.
- From time to time check that there are no loose screws on this unit.
- This product should not be discarded with household waste. Take to your local authority waste disposal centre.

Components - Panels

If you have damaged or missing components, call the **Customer Helpline: 08456 400 800**

Please check you have all the panels listed below

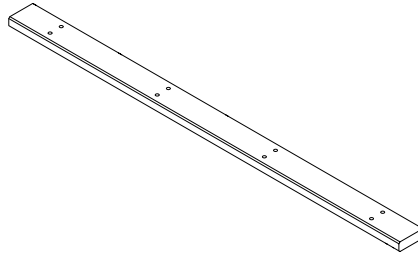
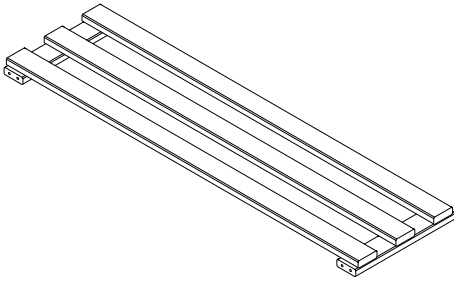

1 Shelf x4 (83.7 x 23.6 cm)

2 Leg x4 (69.9 x 4.5 cm)

Components - Fittings

Please check you have all the fittings listed below

Note: The quantities below are the correct amount to complete the assembly. In some cases more fittings may be supplied than are required.

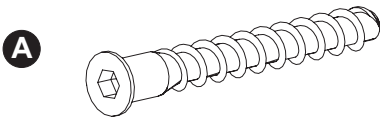

A Screw x 32

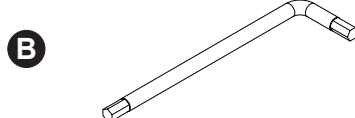

B Allen key x 1

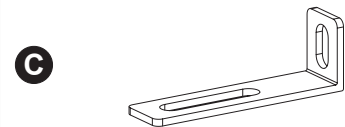

C Angle x 1

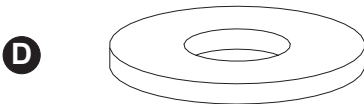

D Washer x 1

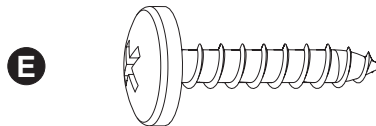

E 15 mm Screw x 1

Ruler - Use this ruler to help correctly identify the screws



Assembly Instructions

Step 1

Insert screw **A** into the screwholes as shown and tighten using a **B** allen key.

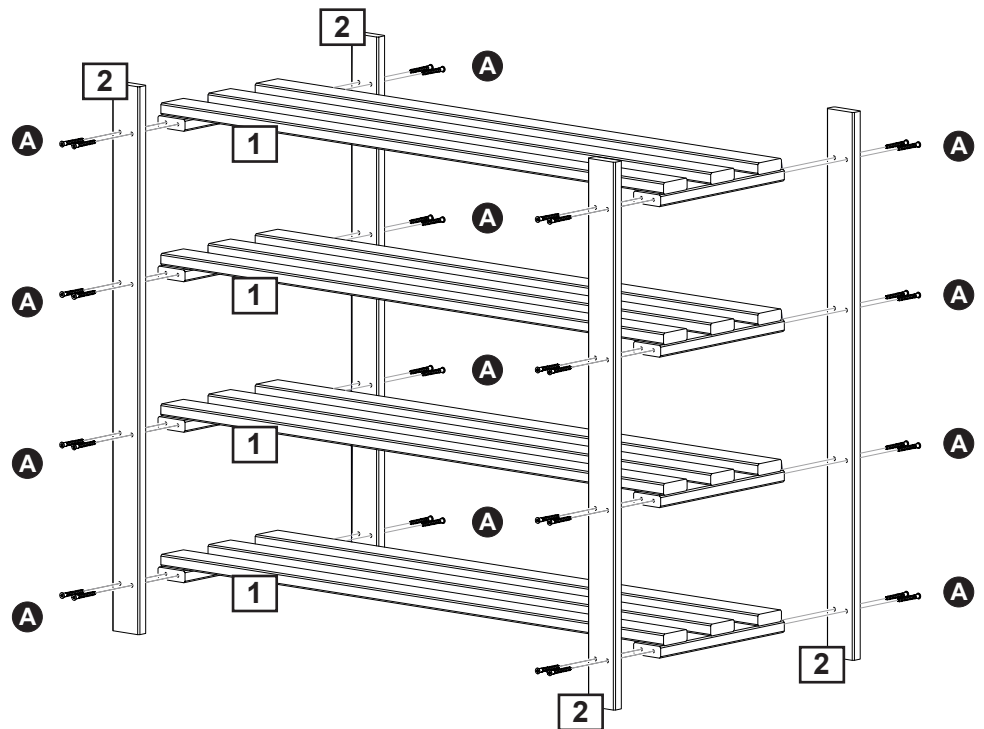

Step 2

Fixing to wall

It is recommended that the storage is fixed to a wall.

Fix angle **C** to top of rack using screw **E**.

Insert screw into the screwhole as shown and tighten using a screwdriver.

Note:

The correct type of fixing must be used for your wall, seek professional advice if in doubt.

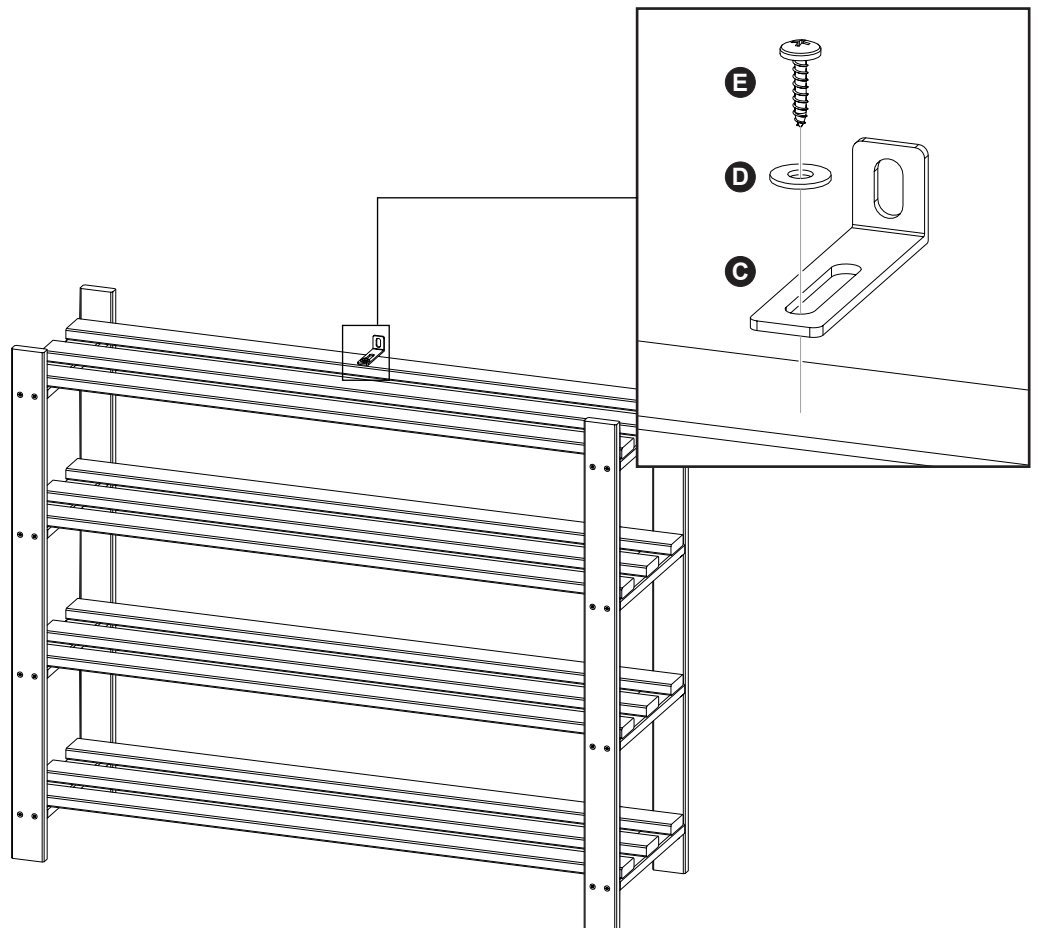

A Guide to - Wall Mounting & Fixings

Important note:

If plastic wall plugs are supplied with your product:



- these are only suitable for use in masonry walls.

If you are in any doubt about the correct wall plugs for your wall, seek professional advice.

Failure of the product due to using incorrect fixings is the responsibility of the installer.



Important: When drilling into walls always check that there are no hidden wires or pipes etc.

Make sure that the screws and wall plugs being used are suitable for supporting your unit. Consult a qualified tradesperson if you are unsure.

Hints:

- 1: **General rule:**  Always use a larger screw and wall plug if you are not sure.
- 2: Ensure you use the recommended drill bit to match the wall plug and hole size.
- 3: Ensure you drill the hole horizontally, do not force the drill or enlarge the hole.
- 4: Take extra care when drilling high walls, ceilings and ceramic tiles. Ensure wall plugs are inserted beyond the thickness of the ceramic tiles to avoid the tiles splitting or cracking.
- 5: Ensure wall plugs are well fitted and are a tight fit in the drilled hole.

Types of walls

You can use one of the following types of wall plug if your walls are made of brick, breeze block, concrete, stone or wood.

No.1 "General Purpose" wall plug

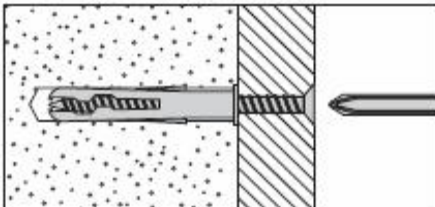

Generally aerated blocks should not be used to support heavy loads, use a specialist fitting in this case. For light loads, general purpose wall plugs can be used.

No.2 "Plasterboard" wall plug

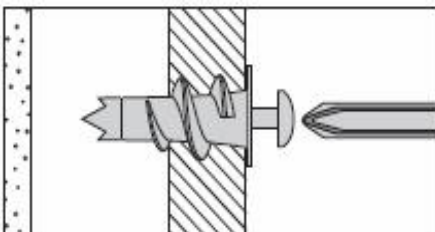

For use when attaching light loads on to plasterboard partitions.

No.3 "Cavity Fixing" wall plug

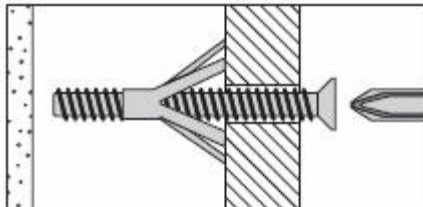

For use with plasterboard partitions or hollow wooden doors.

No.4 "Cavity Fixing-Heavy Duty" wall plug

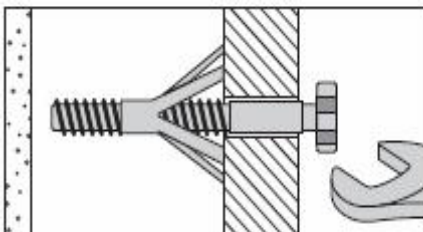

For use when fitting or supporting heavy loads such as shelving, wall cabinets and coat racks.

No.5 "Hammer Fixing" wall plug

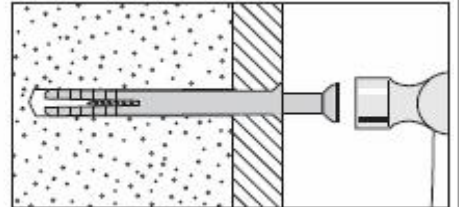

For use with walls stuck with plasterboard. The hammer fixing allows it to be fixed to the wall rather than the plasterboard. Always check the fixing is secure to the retaining wall.

No.6 "Shield Anchor" wall plug
Heavy loads

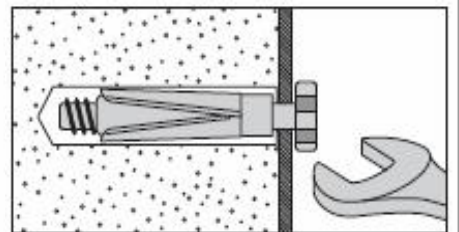

For use with heavier loads such as TV & HiFi speakers and satellite dishes etc.



Care & Maintenance

Safety: Always check the fitting and location to ensure your safety in and around the home.

Fitting: From time to time check the fitting to ensure the wall plugs or screws do not become loose.

Dear Customer

Please note that the product you have purchased is a natural living timber.

Just like nature itself, wood varies in shape and colour. Knots, vein patterns, resin pockets and colour differences contribute to giving the piece of furniture its beauty and form - a natural part of solid wood.

Although the tree has been cut down and dried, it is still alive and therefore will react to high and low temperatures, light, humidity, drought and time.

In cold and dry periods, the wood contracts which may lead to small cracks in the piece of furniture. The reverse happens in warm and humid periods where the wood expands and this may result in slight unevenness.

The colour of the wood also changes with time, particularly if the furniture is placed in a light place. This is a natural process and part of owning a piece of furniture made of solid wood.

Any flexing that has occurred during transport will re-correct itself once this product is correctly assembled.

Tighten all joints of the furniture after six months.

Please keep these instructions in a safe place for future use.