

# 2 IN 1 SWING

Assembly & User Instructions - Please keep for future reference

367/3544

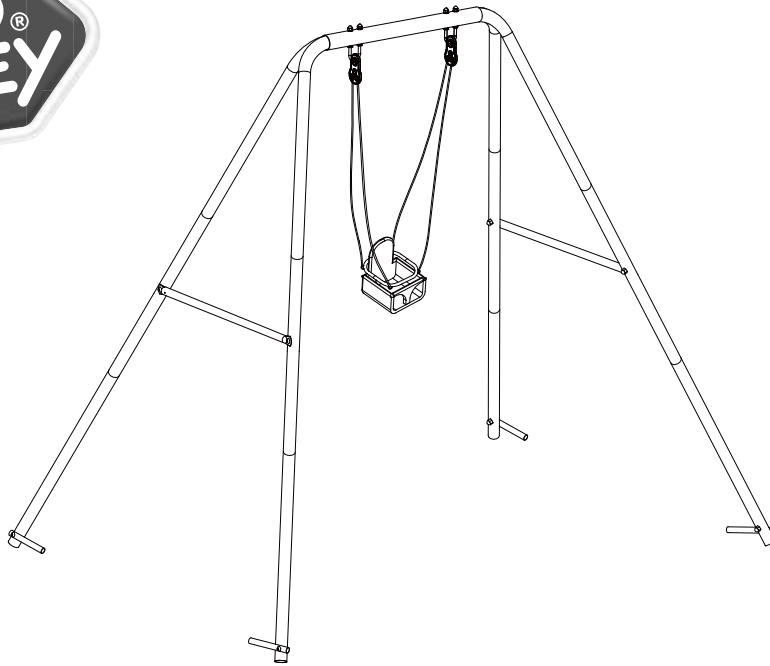

## Assembly

Tips: It will take around 30 minutes to assemble.

2 Adults required

## Important

Age: 3-8 years  
Maximum user weight:  
45kg(Single swing)

Age: 12+months  
Maximum user weight:  
25kg(Baby swing)



**Important** - Please read these instructions fully before assembly or use.

These instructions contain important information which will help you get the best from your product and ensure safe and correct assembly, use and maintenance.

If you need help or have damaged or missing parts, call the **Customer Helpline: (+44) 01702 208117**

# Contents

Safety Information	2
Parts	3
Assembly Instructions	4-8
Care and Maintenance	9

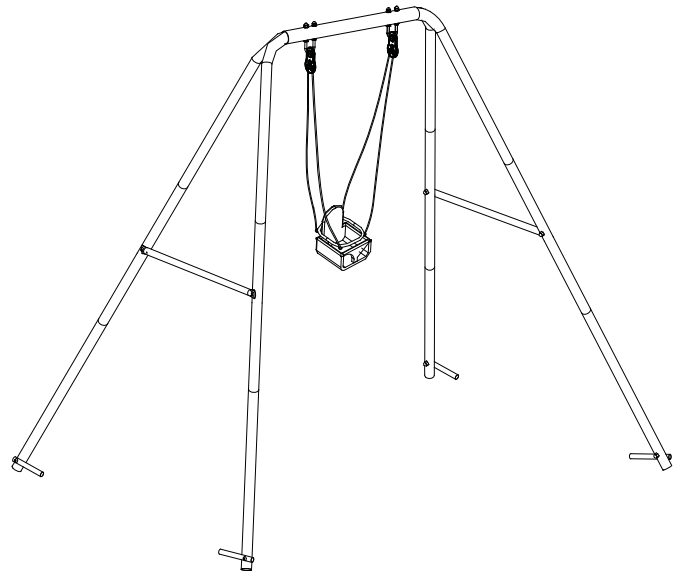



# Safety Information

**Important** –Please read these instructions fully before assembly or use.

## Top Tips before you start

### **WARNING. FOR DOMESTIC USE ONLY.**

- Please check to ensure all parts are present before you start the assembly of this unit. If any missing parts, please properly store the product away and contact our customer service representatives for assistance.
- Assembly by adult(s) required. Do not allow children nearby during assembly to avoid choking hazard from small parts.
- Constant adult supervision is required during use of this product.
- At the start of assembly, do not tighten bolts/nuts completely so as to allow some possible adjustment. After all major components are assembled, go back over all bolts and nuts and properly tighten all of them before using this product.

## Read and follow all instructions

- The single swing is suitable for age 3-8 with maximum user weight of 45kg.
- The nursery swing is suitable for ages 12+months with maximum user weight of 25kg.
- The equipment is designed for outdoor domestic use only and is not permitted for hiring or commercial use.
- Adult supervision is required at all times while the swing is in use. Never leave children unattended during play.
- Do not use the equipment in any manner other than intended.
- Please retain these instructions for future reference
- The product should not be installed over concrete, asphalt or any other hard surfaces. The equipment should be placed on a level surfaces at least 2 m from any structure or obstruction such as a fence, garage, house, overhanging branches, laundry lines or electrical wires.
- Do not use the equipment until it has been fully assembled and anchored, and all the components are properly secured. All the chains/ropes/cables cannot be looped back on themselves.
- Never allow children to disembark from the play equipment whilst it is still in motion.
- Ensure that children are not facing the sun whilst using the equipment.
- Do not attach items to the equipment that are not specially designed for use with this product, including but not limited to cables, shipping ropes and chains as they may cause strangulation hazards.
- Never allow children to walk too close to, in front of, behind or in between the equipment whilst in use, always keep children a safe distance from the product whilst in use.
- Do not allow reckless playing, such as jumping off, standing on seats or climbing ropes.
- Do not allow children to use when the swing seat is wet.

- Instruct children to avoid swinging the empty swing and not twist the swing chain or loop them over the top support bar since this may reduce the strength of the chain or rope.
- Do not allow children to climb on the structure of the swing (eg legs, top bar, cross bars and other parts).
- Instruct child to sit in the centre of the swing with their full weight in the center of the seat.
- Ensure that children wear suitable clothing whilst using this equipment. Never allow children to wear loose clothing, neck ties, scarves, drawstrings or loose jewellery.
- Please remove all packaging and packing tags/ wires before giving this toy to your child. Please take note: As an extra precaution, check this toy regularly for signs of wear or damage. Protective surfacing: One of the most important things you can do to reduce the likelihood of serious head injuries is to install **Shock-Absorbing Protective Surfacing (over the ground)** under and around your play equipment. If you use loose-fill materials such as wood mulch/chips, engineered wood fibre, or shredded/recycled rubber mulch for equipment up to 8 feet high, and 9 inches of sand or pea gravel for equipment up to 5 feet high. NOTE: an initial fill level of 12 inches will compress to about 9 inch depth of surfacing, and settle. The surfacing will also compact, displace, and settle, and should be periodically refilled to maintain at least a 9-inch depth. Carpeting and thin mats are generally not adequate protective surfacing, check and maintain the depth of the loose-fill surfacing material. Maintain the right amount of loose-fill material. Do not install loose fill surfacing over hard surfaces such as concrete or asphalt.

## CARE AND MAINTENANCE INSTRUCTION

- Please carry out and checks and maintenance of the main parts (Crossbeams, suspensions, anchors nuts and bolts) before each use. If these checks are not carried out the toy could overture or otherwise become a hazard. It is of particular importance that they be followed at the beginning of each season as well as at regular intervals during the usage season.
- Check all nuts and bolts for tightness and tighten when required; Oil all metallic moving parts; Check all coverings for bolt and sharp edges and replace when required; Check swing seats, chain, ropes and other means of attachments for evidence of deterioration. Replace when required in accordance with the manufacture's instructions.
- Do not use when temperature drop below 32 degree F.(0 degree C).

# Parts

If you have damaged or missing parts,  
call the **Customer Helpline: (+44) 01702 208117**

Please Check you have all the parts fittings listed below

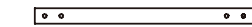

1 Beam x 1pcs

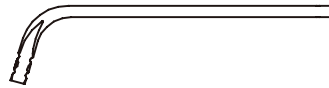

2 Leg x 2pcs

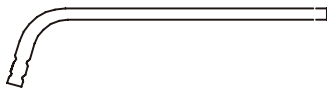

3 Leg x 2pcs



4 Leg x 4pcs

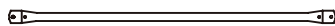

5 Rail x 2pcs

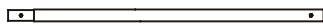

6 Leg x 4pcs



7 Anchor x4pcs

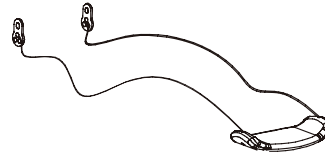

8 Single swing seat x1pcs

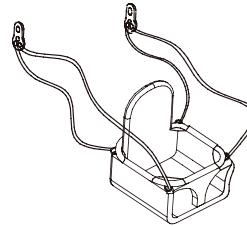









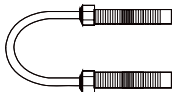



9 Nursery swing seat x1pcs



10 Plastic cap x 4pcs

**Note:** The quantities below are the correct amount to complete the assembly. In some cases more fittings may be supplied than are required.

<p>A</p>  <p>×2(M8)</p>	<p>B</p>  <p>×8(M6×38mm)</p>	<p>C</p>  <p>×4(M6×53mm)</p>	<p>D</p>  <p>×4(M6×42mm)</p>
<p>E</p>  <p>×8 (Ø19×Ø8.5 mm)</p>	<p>F</p>  <p>×32 (Ø14×Ø6.5 mm)</p>	<p>H</p>  <p>×4 (Ø13.5×Ø8.5 mm)</p>	<p>I</p>  <p>×16 (Ø10×Ø6.5 mm)</p>
<p>J</p>  <p>×4 (M8)</p>	<p>K</p>  <p>×16 (M6)</p>	<p>W</p>  <p>x 1 (10mm)</p>	<p>Z</p>  <p>x 1 (4mm)</p>

**Ruler - Use this ruler to help correctly identify the bolts/screws**

0 5 10 15 20 25 30 35 40 45 50 55 60 65 70 75 80 85 90 95 100 105 110 115 120 125 130 135 140 145 150 155 160 165 170

# Assembly Instructions

## Step 1

Insert Legs (2) and (3) into Beam (1) as shown in Figure 1. Please note the order of Legs (2) and (3) need to be inverse on the two sides of the beam.

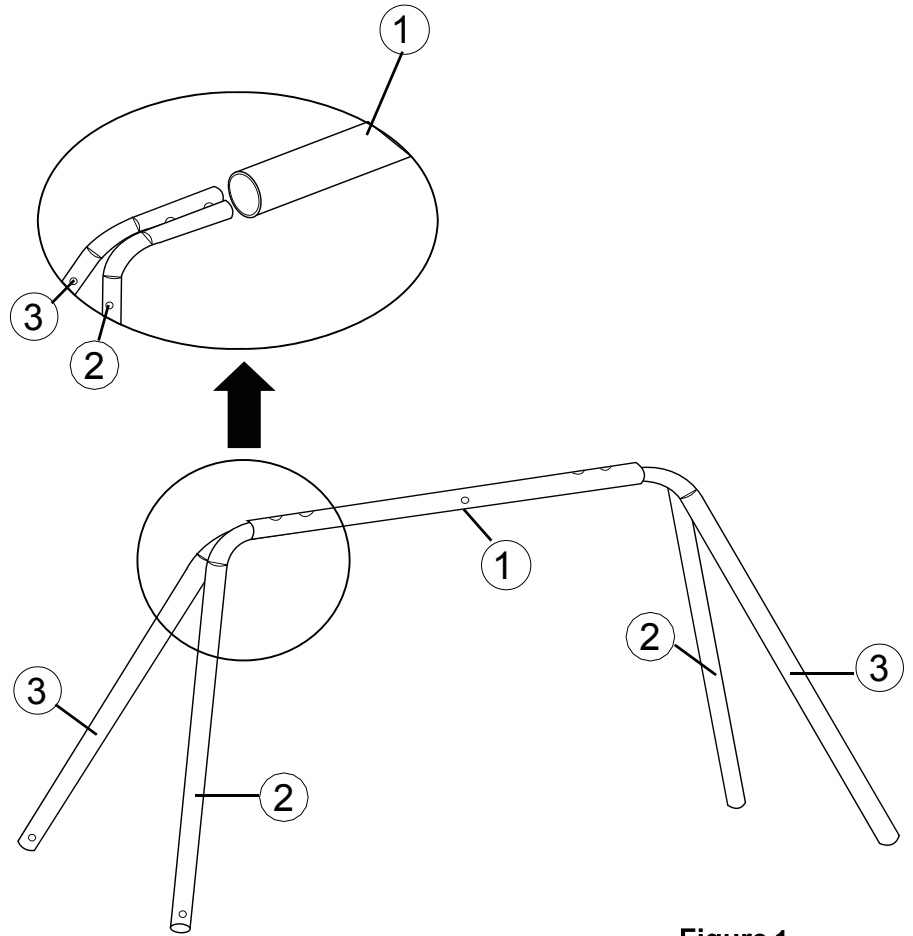
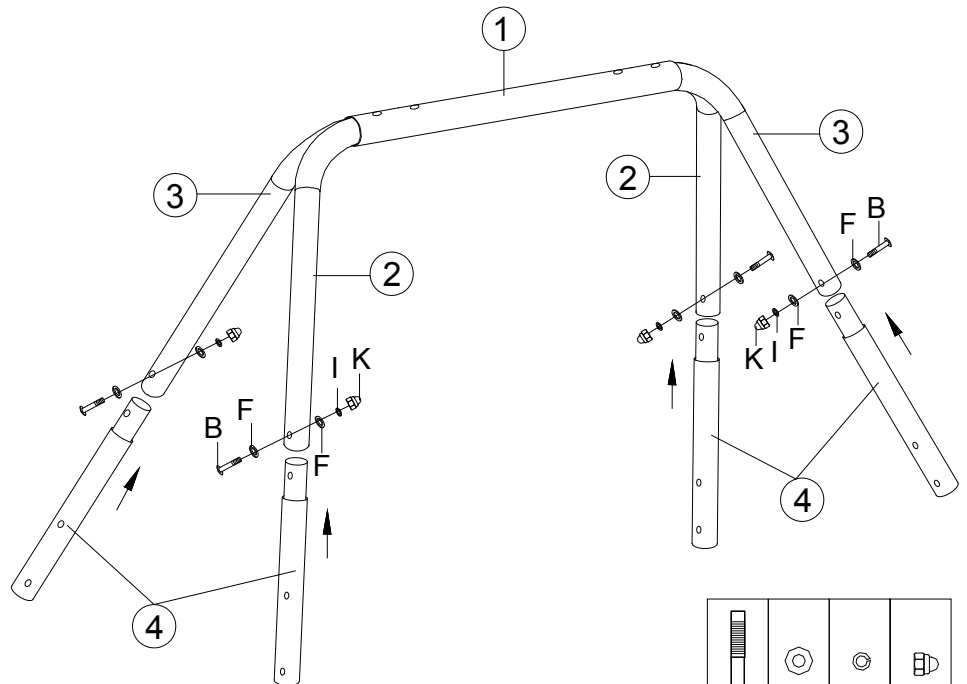

Figure 1

## Step 2

Insert Legs (4) into (2) and (3). Secure with B,F,I and K in the sequence shown in Figure 2.



B x 4pcs	F x 8pcs	I x 4pcs	K x 4pcs

Figure 2

# Assembly Instructions

## Step 3 (a)

Attach Plastic Cap (10) to each side of Rail (5)  
Secure Rail to Legs (4) on both sides of the swing using D,F,I and K in the sequence shown in FIGURE 3-1.

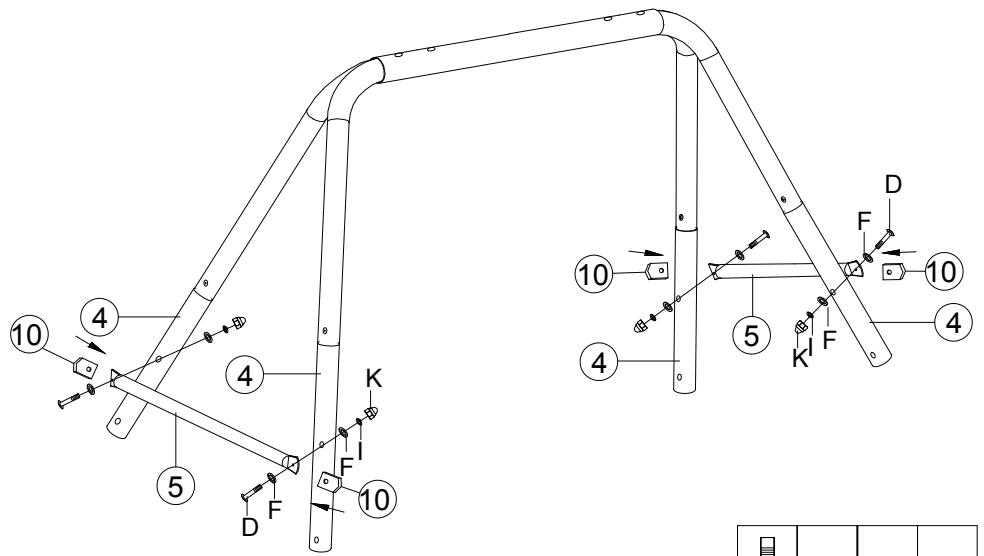

D	F	I	K
x 4pcs	x 8pcs	x 4pcs	x 4pcs

**Figure 3-1**

## Step 3 (b)

Attach Legs (6) to (4) using B,F,I and K in the sequence shown in FIGURE 3-2.

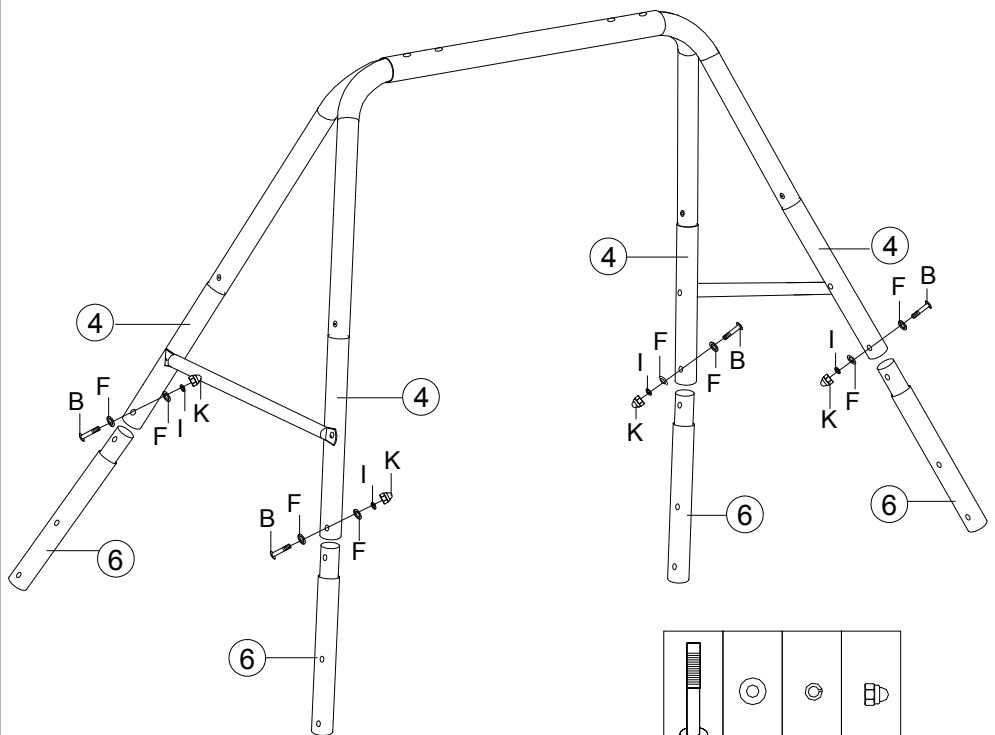

B	F	I	K
x 4pcs	x 8pcs	x 4pcs	x 4pcs

**Figure 3-2**

# Assembly Instructions

## Step 4 (For Nursery Swing Seat)

Loop U-bolt (A) through the plate at the top of the swing and secure it to Beam (1) using E, H, and J in the sequence shown in FIGURE 4-1

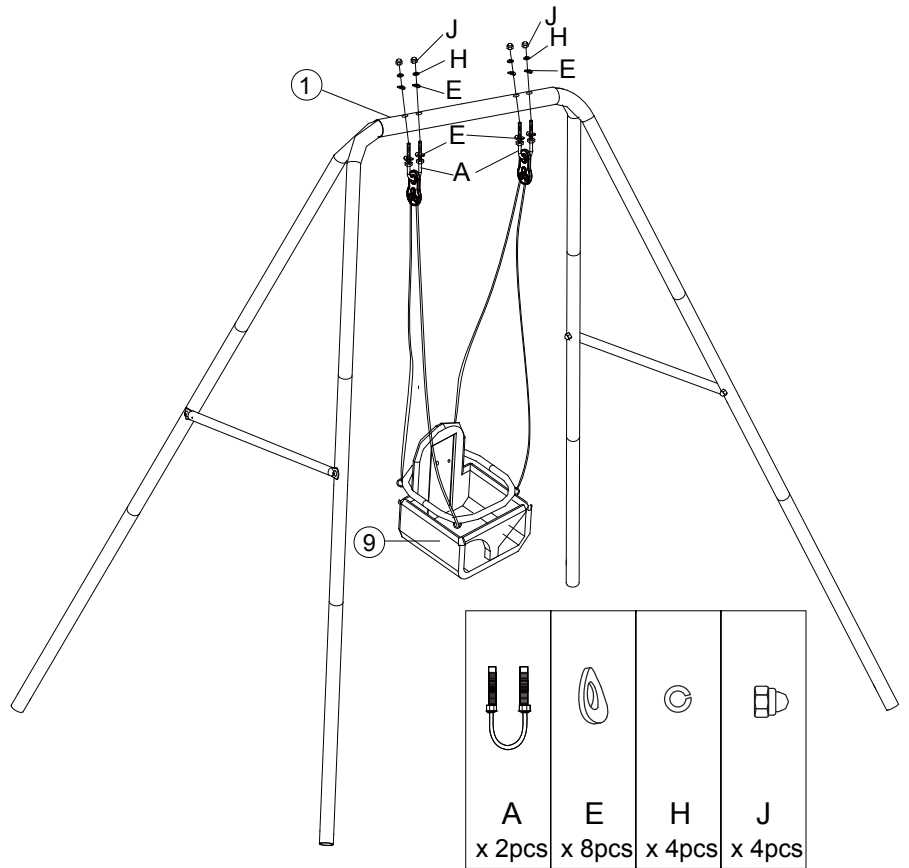

Figure 4-1

## Step 4 (For Single Swing Seat)

Loop U-bolt (A) through the plate at the top of the swing and secure it to Beam (1) using E,H and J in the sequence shown in FIGURE 4-2.

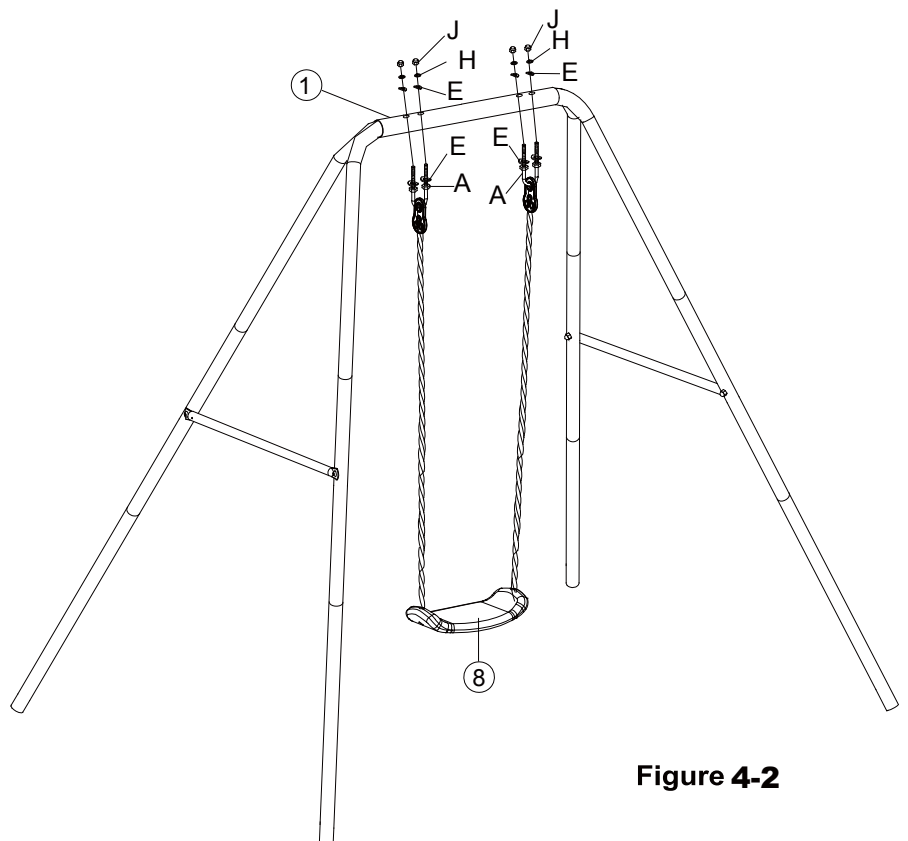

Figure 4-2

# Assembly Instructions

## Step 5

Attach Anchor (7) to the base of all four Legs (6) using C, F, I and K in the sequence shown in FIGURE 5.

**IMPORTANT: AFTER COMPLETING ALL THE STEPS, GO OVER THE ENTIRE UNIT AND TIGHTEN ALL BOLTS BEFORE ALLOWING CHILDREN TO USE.**

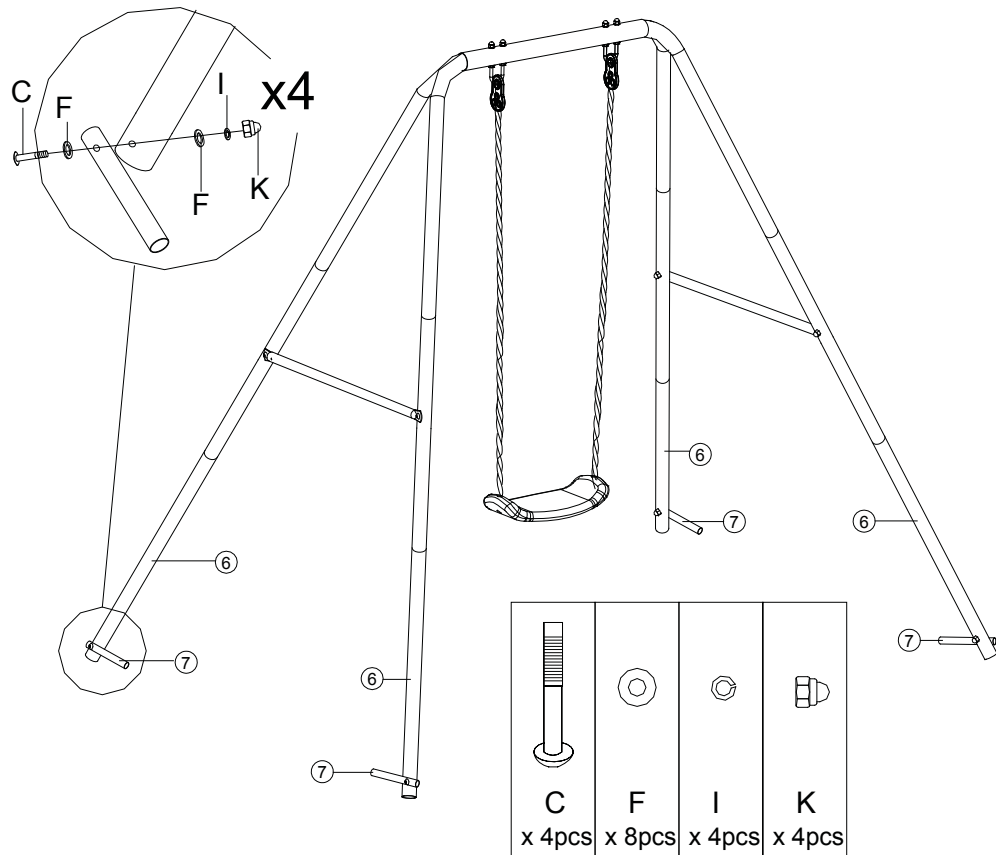
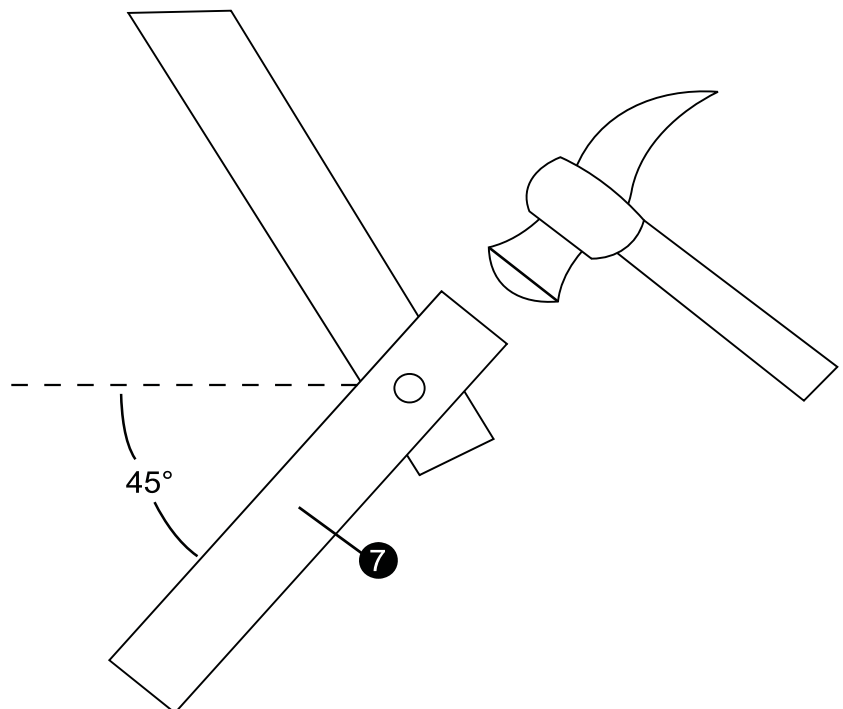

Figure 5

## Step 6

Position the anchors at 45 degree angle and secure them fully into the ground until the leg of the swing is standing flat and stable on the ground.





# Assembly Instructions

To secure the child in the nursery swing

**Note :** Lock the seat belt tightly over the child.

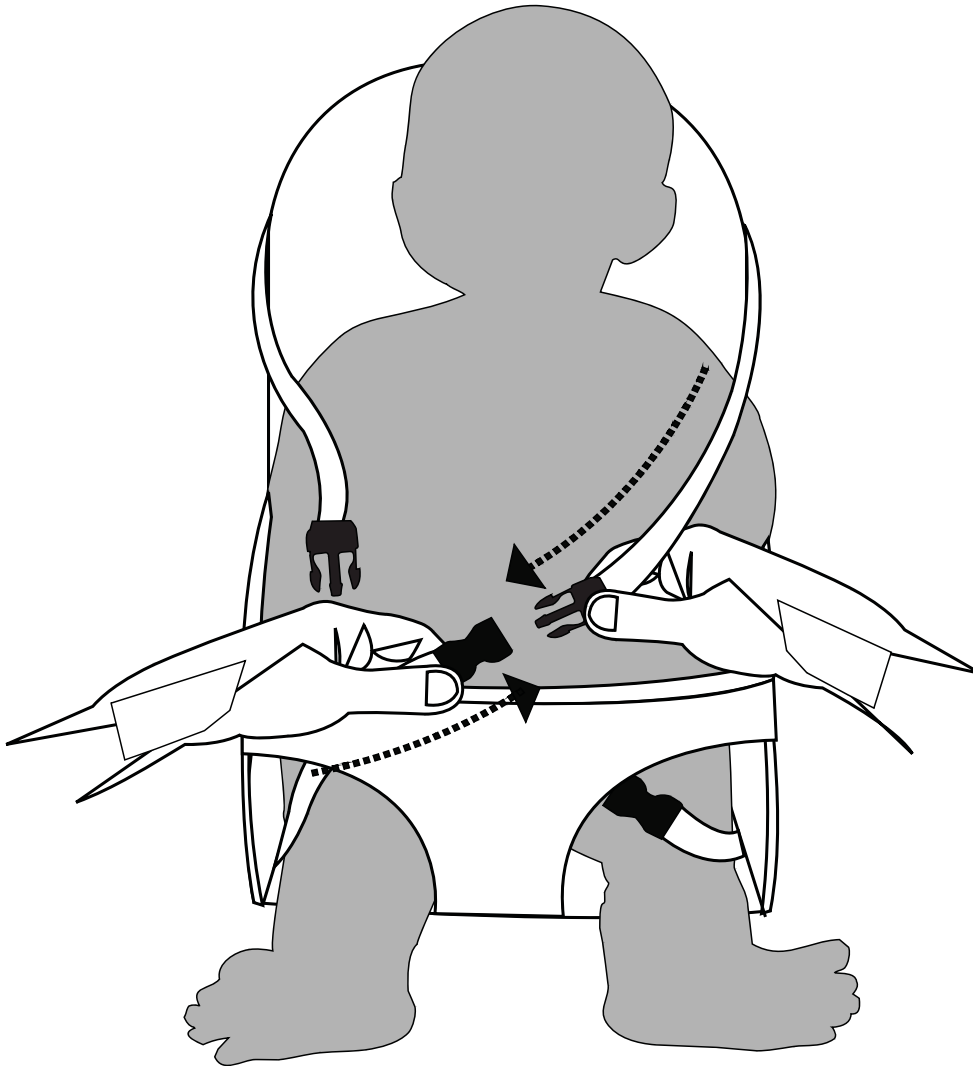

**WARNING!**

CONSTANT ADULT SUPERVISION REQUIRED AT ALL TIMES DURING USE.

# Care and Maintenance

## General

This 2 in 1 Swing was designed and manufactured with quality materials and craftsmanship.

If correct care and maintenance is provided, it will provide users with years of exercise, fun and enjoyment.

### Inspect regularly for:

- CHECK ALL NUTS AND BOLTS TWICE MONTHLY DURING THE USAGE SEASON FOR TIGHTNESS AND TIGHTEN AS REQUIRED. IT IS PARTICULARLY IMPORTANT THAT THIS PROCEDURE BE FOLLOWED AT THE BEGINNING OF EACH SEASON.
- Never use pliers to tighten up screws –these can cause damage to both the paintwork and the special anti-corrosion plating.
- Tighten all nuts and bolts securely. Replace as needed. If not checked regularly, bolts can be loose or missed and components can become detached and cause injuries.
- Check the unit at the beginning of the usage season and monthly thereafter for evidence of deterioration.
- Immediately remove and replace any items that appear to be weak or broken. Contact Customer Support for replacement parts.
- Check all covers designed for bolts and sharp edges regularly to be certain they are present and in good condition. Replace as needed. It is particularly important that all covers are checked prior to the first use each season.
- Inspect handle bar, hardware, and etc., for proper closure and for signs of wear, deterioration, rust and/or damage. Replace as needed.
- Lubricate all metallic moving parts monthly during the usage season. Applying a light coat of automobile wax to all metal tubing surfaces will help protect your unit and add to its longevity. Sand any rusted areas of the metal tubing and repaint using a non-lead based paint.
- Remove plastic seats and store indoors, or do not use when the temperature drops below 32°F/0°C.
- Check unit for scuffs, burrs, sharp edges and any other defects that may occur from assembly, abuse, shipping or everyday use. Burrs and sharp edges may be filed down until smooth and covered with duct tape if necessary.
- To help maintain the products appearance, occasionally clean the seats and metal framework with a damp cloth lightly – but DO NOT use abrasive chemical cleaners.
- When the time comes to disassemble and dispose of this product, please completely disassemble the unit and discard of it in a safe place and manner so as not to present any hazard to any individual. It is important to check and maintain the main parts at regular intervals.If these checks are not carried out,the toy could overturn or otherwise become a hazard.Whenever practical,the instructions shall also be affixed to the toy.

**IMPORTANT!KEEP FOR FUTURE REFERENCE.**

### WARNING!

- Nursery Swing is suitable for children by ages 12+months with maximum weight of 25kg.
- Single Swing is suitable for children between 3-8 years old with maximum weight of 45kg.
- Do not allow more than one user at the same time.
- Constant adult supervision required at all times during use. Do not leave children unattended.
- For domestic use only. Not for rental or commercial use.
- Adult assembly required. Make sure to properly dispose of all packaging material and do not allow children nearby during assembly due to small parts: choking hazard!



If you need help or have damaged or missing parts, call the Customer Helpline: (+44) 01702 208117  
Produced for Chad Valley Toys. Argos Ltd. Country of origin: China  
Address: 489 - 499 Avebury Boulevard, Central Milton Keynes, MK9 2NW. [www.argos.co.uk](http://www.argos.co.uk)