

Normandy - Tall 3+3 Mirror Robe

Assembly Instructions - Please keep for future reference

355/6324

338/3267

357/5563

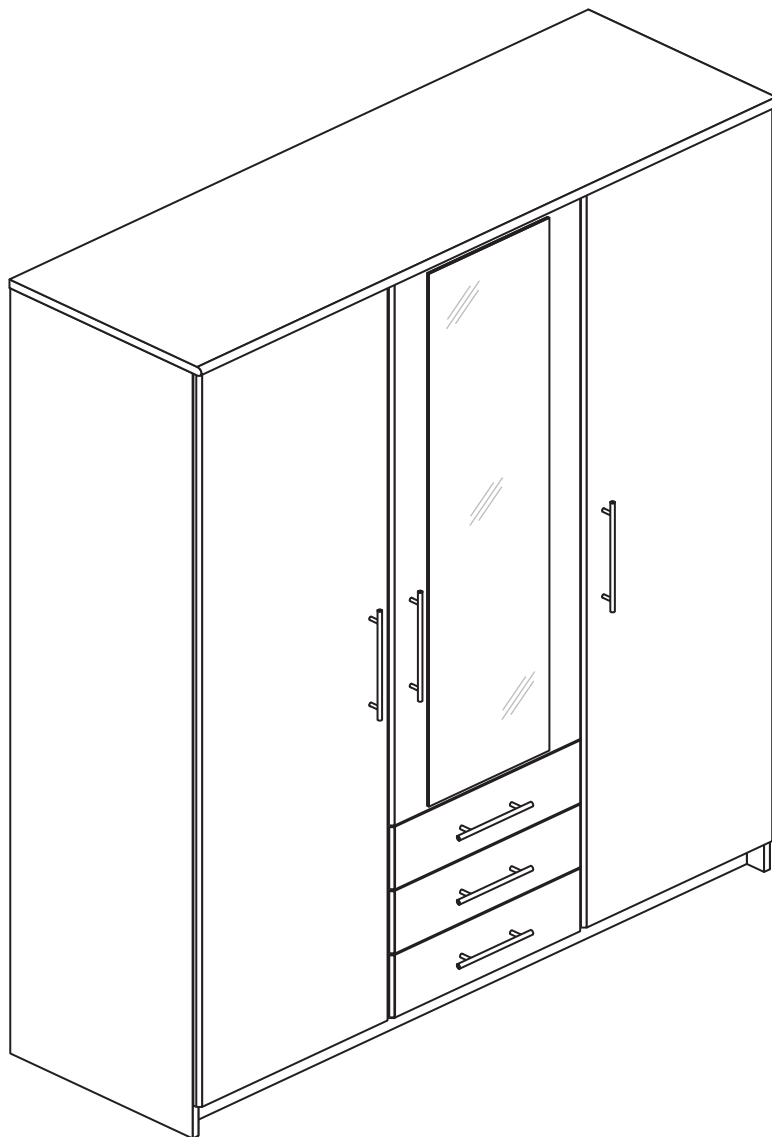

Dimensions

Width - 149.5cm

Depth - 50cm

Height - 199.5cm



**MADE IN
BRITAIN**

Important - Please read these instructions fully before starting assembly

If you need help or have damaged or missing parts, call the **Customer Helpline: 08456 400800**



Safety and Care Advice

Important - Please read these instructions fully before starting assembly

- **Warning:** This unit weighs approximately 108kgs. Please lift with care.
- Check you have all the components and tools listed on pages 2 and 3.
- Remove all fittings from the plastic bags and separate them into their groups.
- Keep children and animals away from the work area, small parts could choke if swallowed.
- Parts of the assembly will be easier with 2 people.

- Make sure you have enough space to layout the parts before starting.
- Do not stand or put weight on the product, this could cause damage.
- Assemble the item as close to its final position (in the same room) as possible.
- Assemble on a soft level surface to avoid damaging the unit or your floor (use opened out unit carton).



- We do not recommend the use of power drill/drivers **for inserting screws**, as this could damage the unit. Only use hand screwdrivers.

- **Safety note:** It is recommended that this unit is secured to a wall using the bracket supplied.

- Dispose of all packaging carefully and responsibly.

Care and maintenance

- Only clean using a damp cloth and mild detergent, do not use bleach or abrasive cleaners.
- From time to time check that there are no loose screws on this unit.
- This product should not be discarded with household waste. Take to your local authority waste disposal centre.

Components - Panels

If you have damaged or missing components, call the **Customer Helpline: 08456 400800** quoting the reference numbers below

Please check you have all the panels listed below

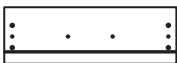

1 Drawer Front (DF1859)
(494 x 162mm) x 3

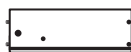

2 Left Drawer Side (W350-124LH)
(350 x 124mm) x 3

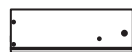

3 Right Drawer Side (W350-124RH)
(350 x 124mm) x 3

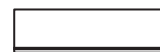

4 Drawer Back (W436-124)
(436 x 124mm) x 3



5 Drawer Base (T447-367)
(447 x 367mm) x 3



6 Top (D2047A)
(1495 x 496mm)

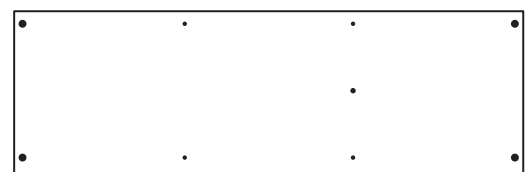

7 Base (DF1969A)
(1461 x 470mm)

Components - Panels

If you have damaged or missing components, call the **Customer Helpline: 08456 400800** quoting the reference numbers below

Please check you have all the panels listed below



8 Left Side (D2048C)
(1978 x 471mm)



9 Right Side (D2049C)
(1978 x 471mm)

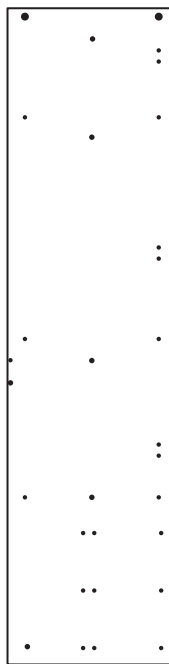

10 Divider (DF1870)
(1883 x 469mm)



11 Large Shelf (D2052A)
(965 x 467mm)

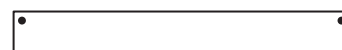

12 Back Rail (D2053A)
(965 x 120mm)

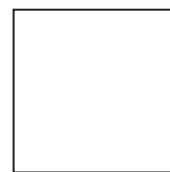

13 Small Shelf (D2060A)
(479 x 467mm)



14 Plinth (D2054A)
(1461 x 80mm) x 2

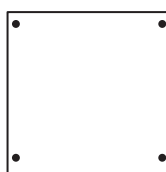

15 Horizontal (DF1871)
(468 x 468mm)

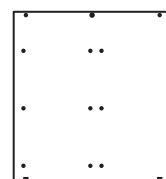

16 Small Divider (DF1872)
(489 x 469mm)

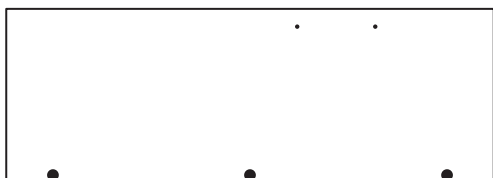

17 Mirror Door (DF1858A) (Mirror - SG14
1376 x 311mm
Safety Back SAR)

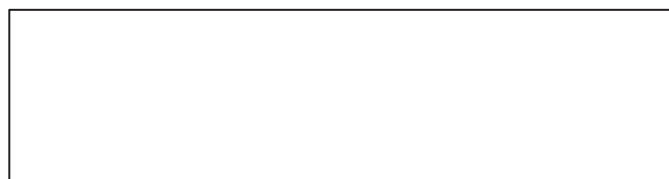

21 Small Back (X955)
(1914 x 499mm)

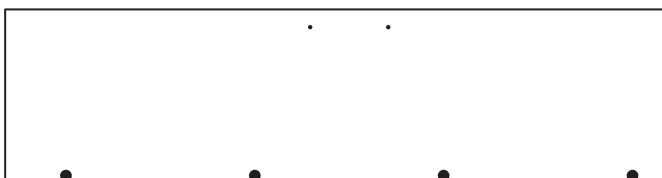

18 Plain Door (D2056A)
(1894 x 494mm) x 2



19 Large Hanging Rail (FHR957)
(957mm long) x 2



20 Small Hanging Rail (FHR471)
(471mm long) x 2

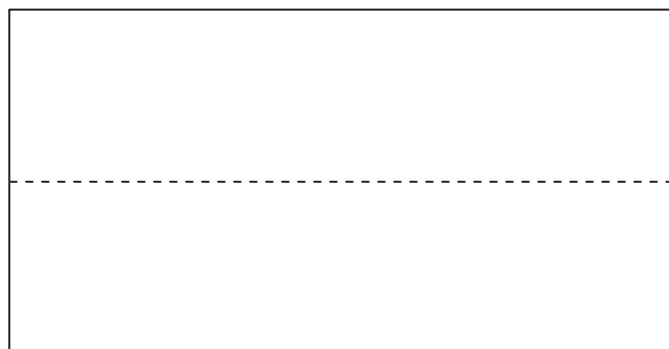

22 Large Back (X956)
(1914 x 988mm)











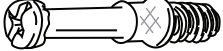









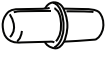

Components - Fittings

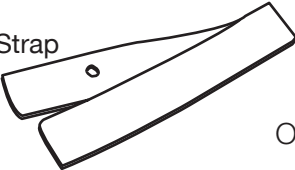
If you have damaged or missing components, call the **Customer Helpline: 08456 400800** quoting the reference numbers below

Please check you have all the fittings listed below

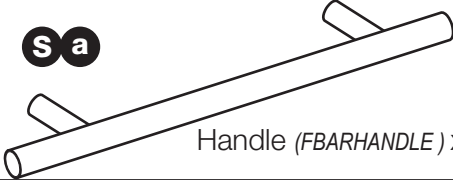
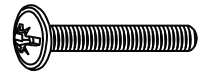
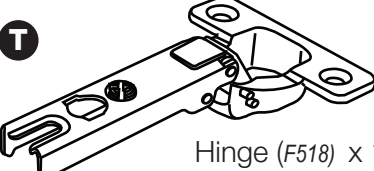
Note: The quantities below are the correct amount to complete the assembly. In some cases more fittings may be supplied than are required.

<p>A </p> <p>Wooden dowel (F22) x 14</p>	<p>B </p> <p>Metal dowel (F901) x 26</p>	<p>C </p> <p>Small locking nut (F3) x 6</p>
<p>D </p> <p>Large locking nut (F900) x 20</p>	<p>E </p> <p>Nail screw (F277) x 6</p>	<p>F </p> <p>Back holder (F276) x 6 *These can also be round</p>
<p>G </p> <p>13mm Screw (F63) x 30</p>	<p>H </p> <p>9mm Screw (F73) x 12</p>	<p>I </p> <p>9mm Screw (F74) x 6</p>
<p>J </p> <p>40mm Screw (F910) x 4</p>	<p>K </p> <p>Nail (F51) x 45</p>	<p>L </p> <p>Knock-in Peg (F171GY) x 12</p>
<p>M </p> <p>Rail holder (F1014) x 8</p>	<p>N </p> <p>Shelf stud (F110) x 8</p>	<p>O </p> <p>Plastic Nail (F91) x 6</p>
<p>P </p> <p>Wedgefix (F639) x 6</p>	<p>Q    Washer x 2</p> <p>Overbalance protector kit (F269) x 1</p>	
<p>R </p> <p>Hinge plate (F523) x 11</p>	<p>S a </p> <p>Handle (FBARHANDLE) x 6</p>	<p>S b </p> <p>Handle screw (F461) x 12</p>
<p>T </p> <p>Hinge (F518) x 11</p>	<p>U </p> <p>Drawer runner (F1004) x 6</p>	

Ruler - Use this ruler to help correctly identify the screws

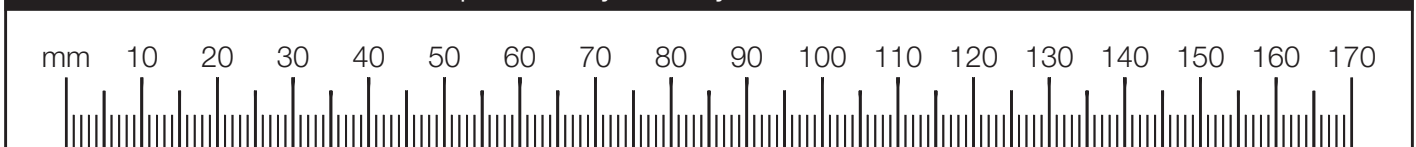

Assembly Instructions

If you have damaged or missing components, call the
Customer Helpline: 08456 400800 quoting the reference
numbers below

Step 1

Prepare the 3 drawer fronts

Screw 2 metal dowels **B** into each of the drawer fronts **1**.

Note: Tighten the metal dowels up fully against the panels.

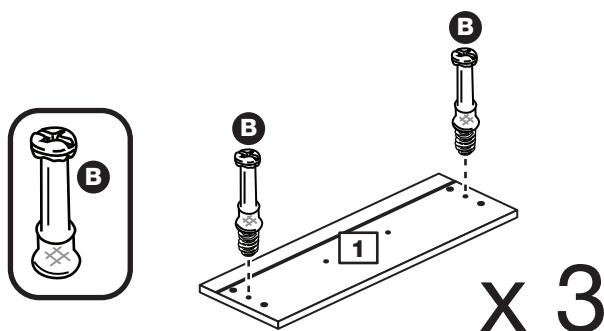

Step 2

Prepare the drawer sides

Insert a small locking nut **C** into the hole shown on the left drawer side **2** and the right drawer side **3**.

Note: The arrow on the locking nut **must** point towards the hole in the edge of the panel.

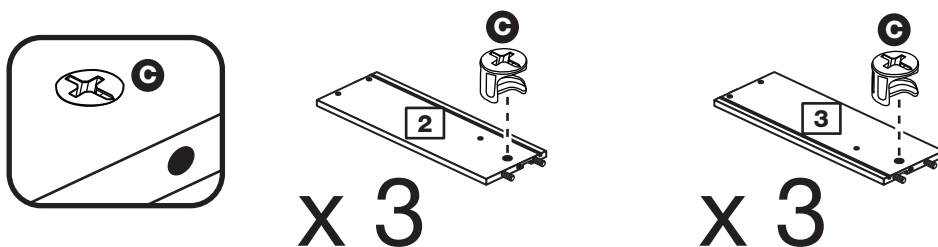

Step 3

Attach the drawer sides to the drawer fronts

Push the left drawer sides **2** and right drawer sides **3** onto the back of the drawer fronts **1**.

Turn the small locking nuts **C** on the left drawer side **2** and right drawer side **3**.

Note: Turn the locking nuts **C** clockwise to secure panels - more than 1/2 a turn.

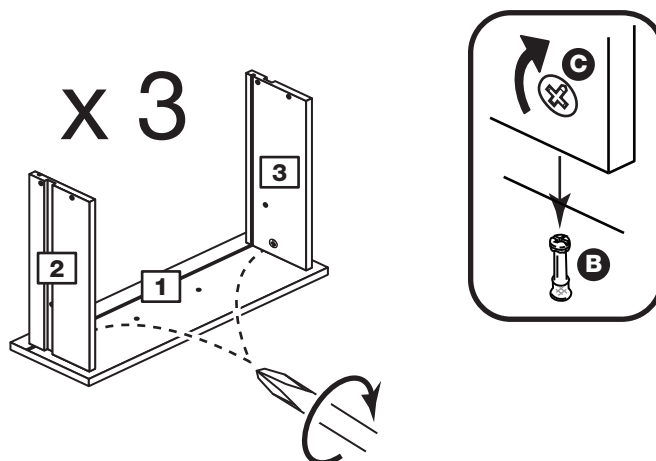

Assembly Instructions

Step 4

Fit the drawer base

Slide the drawer base **5** down the grooves in the drawer sides **2** and **3** and down into the groove in the drawer front **1**.

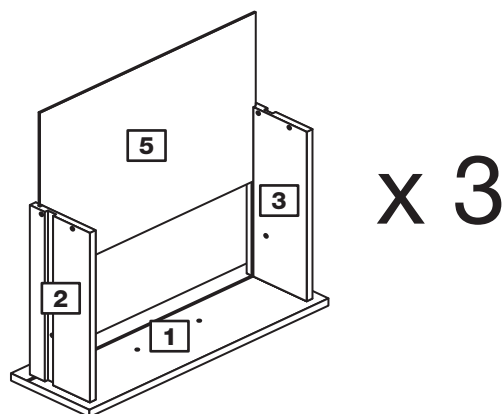

Step 5

Fit the drawer back

Fit the drawer back **4** between the drawer sides **2** and **3**. Make sure that the drawer base **5** fits into the groove in the drawer back **4**.

Hold the drawer back **4** in position and tap the knock-in pegs **L** through the holes in the drawer sides **2** and **3**.

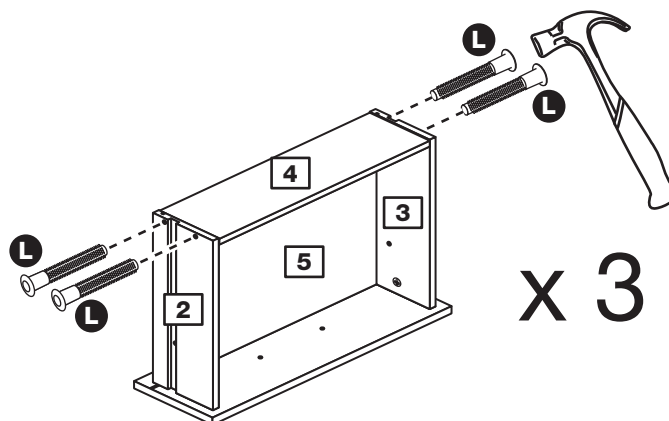

Step 6

Attach the handles

Attach a handle **Sa** to each drawer front **1** using 2 screws **Sb**.

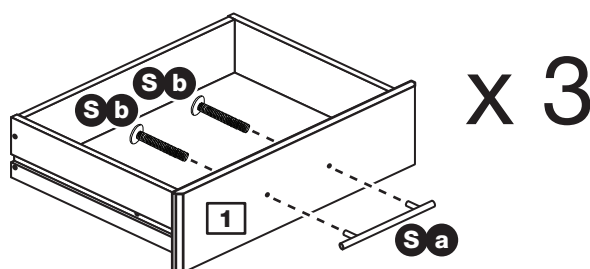

Step 7

Fit the wedgexes

Turn the drawer assemblies over and slide 2 wedgexes **P** into the front and back grooves, as shown, and tighten up the screws.

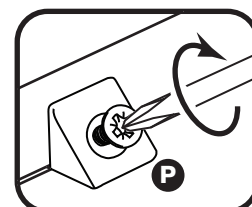
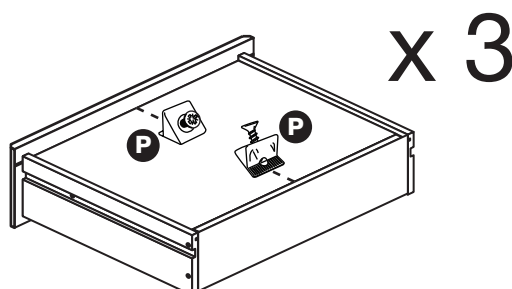

Assembly Instructions

Step 8

Prepare the divider

a: Place a runner **U** on the divider **10**. Slide back the top of runner and use the 2nd hole from the front to fit the 1st screw **H**.

b: Slide the runner back the other way and fit the 2nd screw **H** into the corresponding hole in the divider **10**.

Fit 3 hinge plates **R** onto the divider **10**, making sure that the slot is facing towards the finished front edge.

c: Tap 2 wooden dowels **A** into the divider **10**.

Screw 3 metal dowels **B** into the divider **10**.

Insert 2 large locking nuts **D** into the divider **10**.

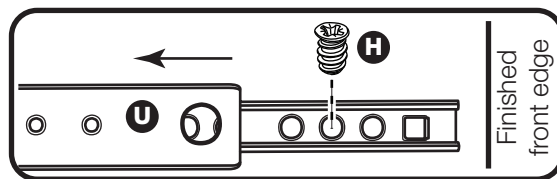

a:

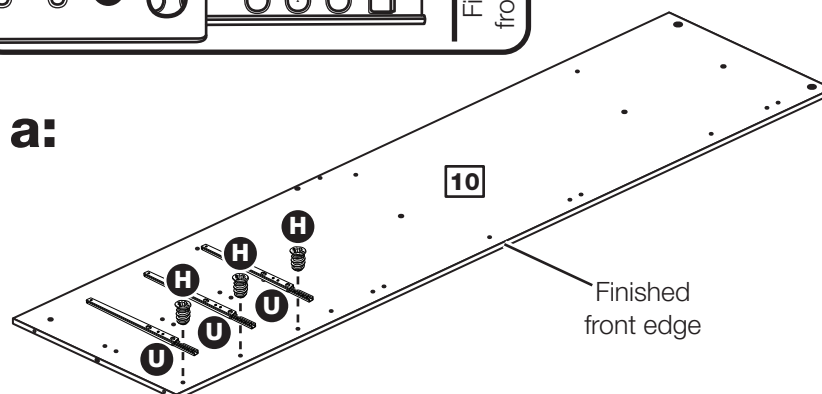

b:

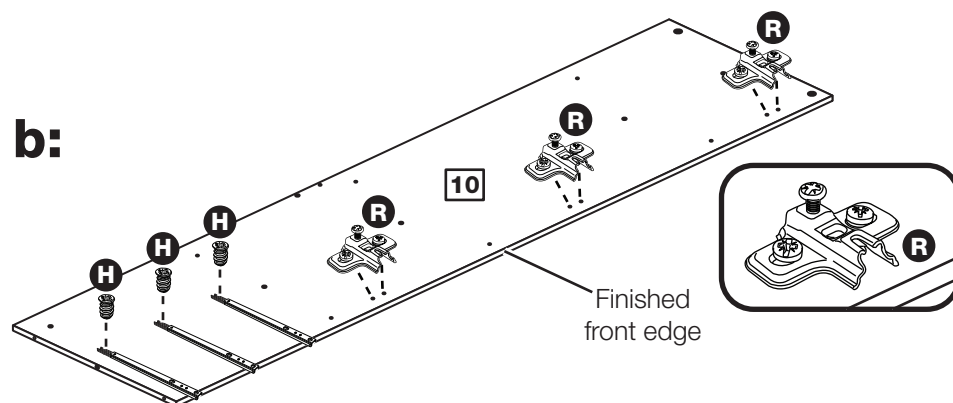

c:

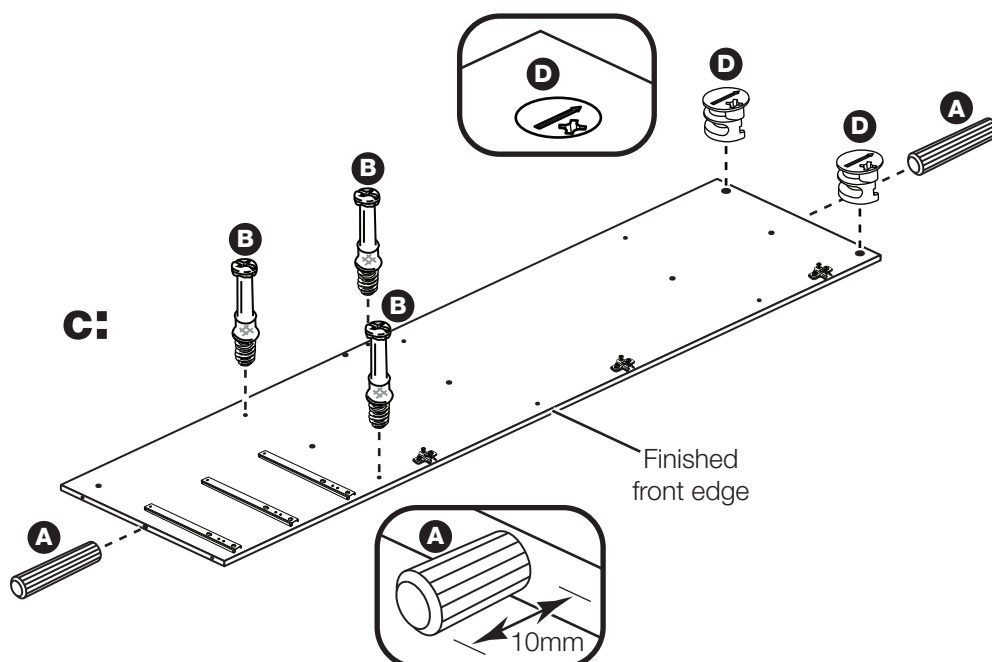

Assembly Instructions

Step 9

Prepare the horizontal

Insert 4 large locking nuts **D** into the horizontal **15**.

Tap 2 wooden dowels **A** into the horizontal **15**.

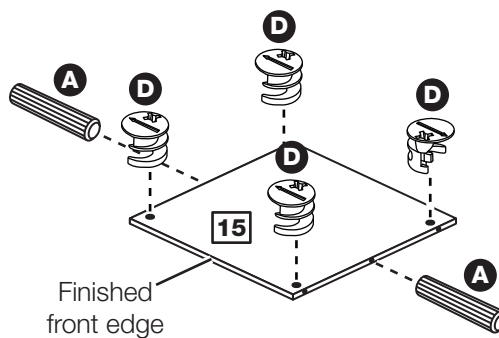

Step 10

Fit the horizontal to the divider

Push the horizontal **15** onto the divider **10**.

Use a screwdriver to tighten the 2 large locking nuts **D** fitted to the horizontal **15**.

Note: Turn the large locking nuts **D** as far as they will go - more than 1/2 a turn.

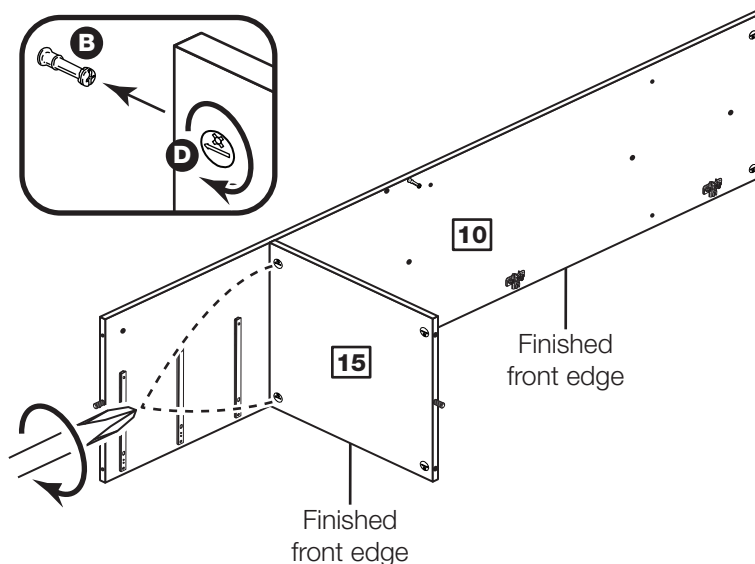

Step 11

Prepare the small divider

a: Place a runner **U** on the small divider **16**. Slide back the top of runner and use the 2nd hole from the front to fit the 1st screw **H**.

b: Slide the runner back the other way and fit the 2nd screw **H** into the corresponding hole in the small divider **16**.

Screw 2 metal dowels **B** into the small divider **16**.

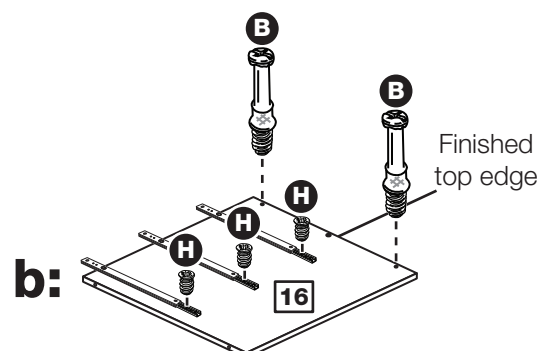
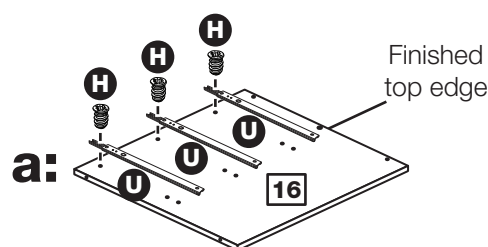
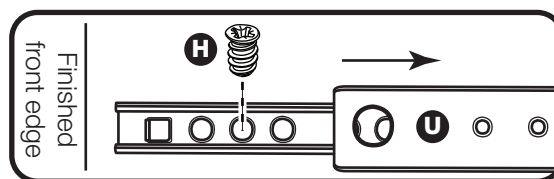

Assembly Instructions

Step 12

Fit the small divider to the horizontal

Push the small divider **16** onto the horizontal **15**.

Use a screwdriver to tighten the 2 large locking nuts **D** fitted to the horizontal **15**.

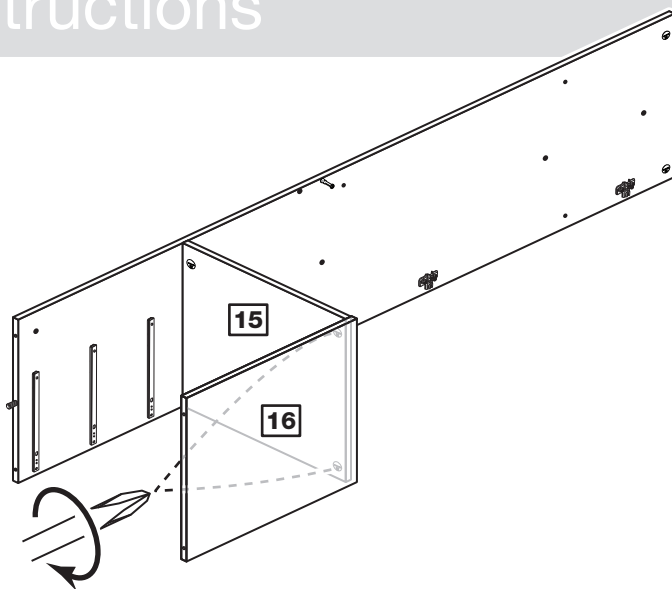

Step 13

Prepare the base

Insert 4 large locking nuts **D** into the base **7**.

Tap 2 wooden dowels **A** into the base **7**.

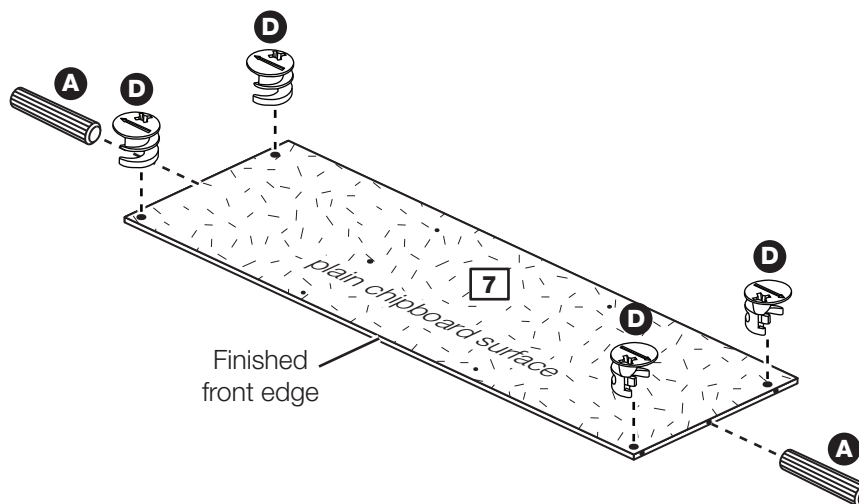

Step 14

Fit the base

Push the base **7** onto the divider **10** and small divider **16** and secure with 4 screws **J**.

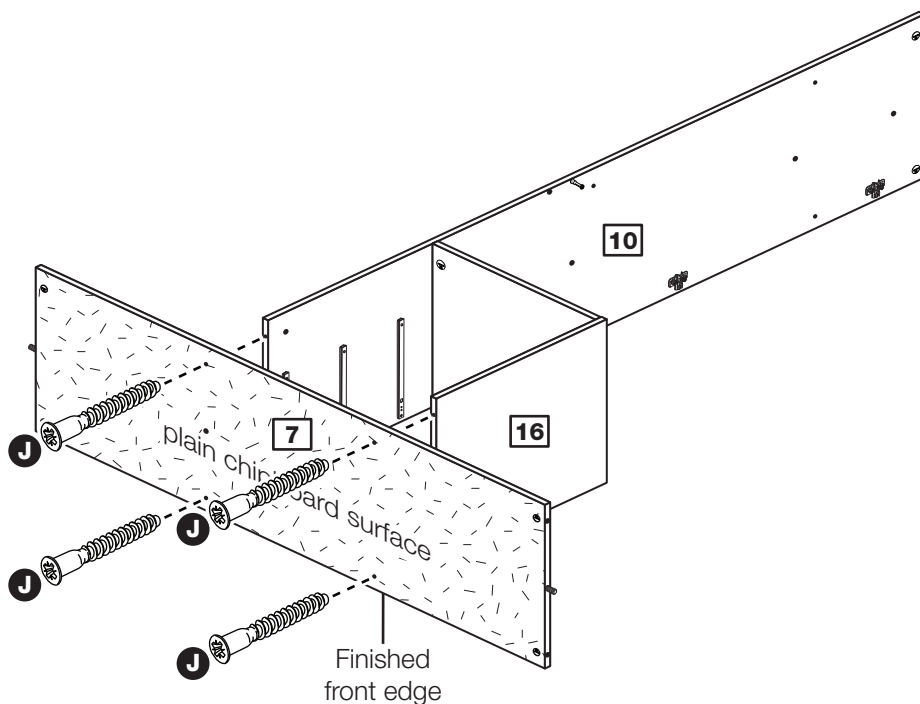

Assembly Instructions

Step 15

Prepare the left side

Screw 5 metal dowels **B** into the left side **8**.

Fit 4 hinge plates **R** onto the left side **8**, making sure that the slot is facing towards the finished front edge.

Insert 2 large locking nuts **D** into the left side **8**.

Tap a wooden dowel **A** into the left side **8**.

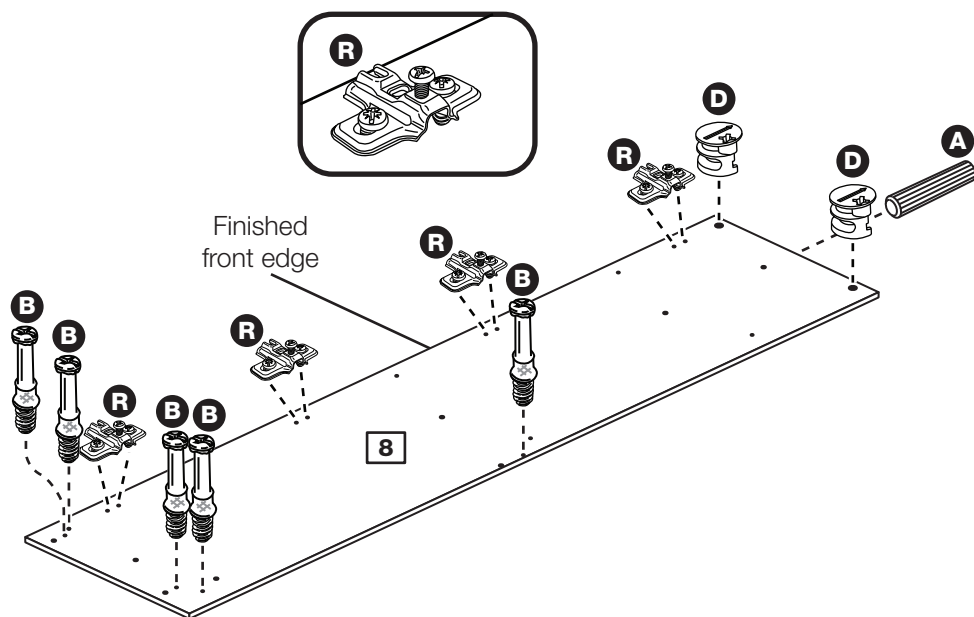

Step 16

Prepare the right side

Screw 4 metal dowels **B** into the right side **9**.

Fit 4 hinge plates **R** onto the right side **9**, making sure that the slot is facing towards the finished front edge.

Insert 2 large locking nuts **D** into the right side **9**.

Tap a wooden dowel **A** into the right side **9**.

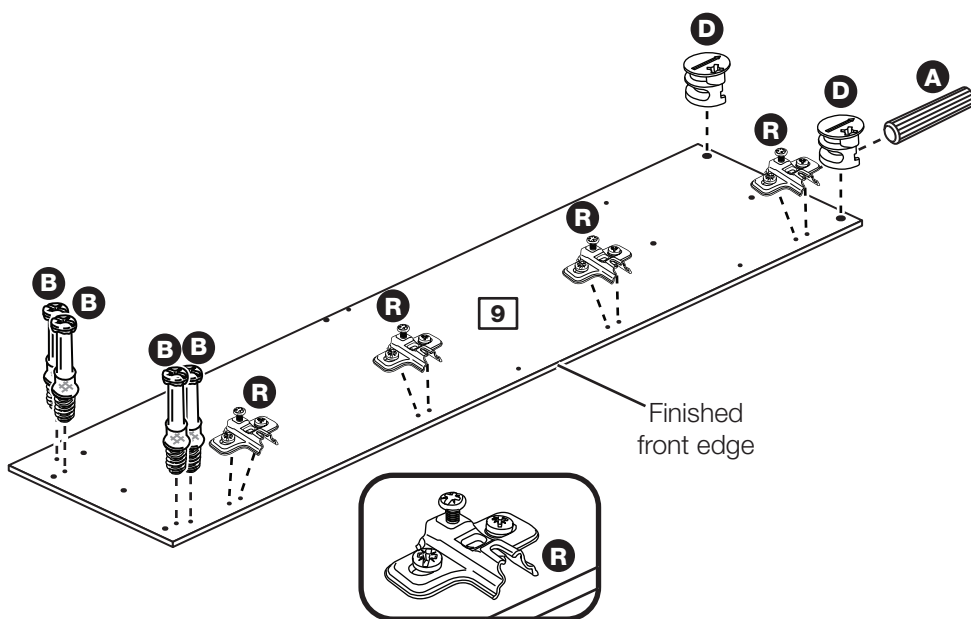

Assembly Instructions

Step 17

Fit the right side to the base

Push the right side **9** onto the base **7**.

Use a screwdriver to tighten the 2 large locking nuts **D** fitted to the base **7**.

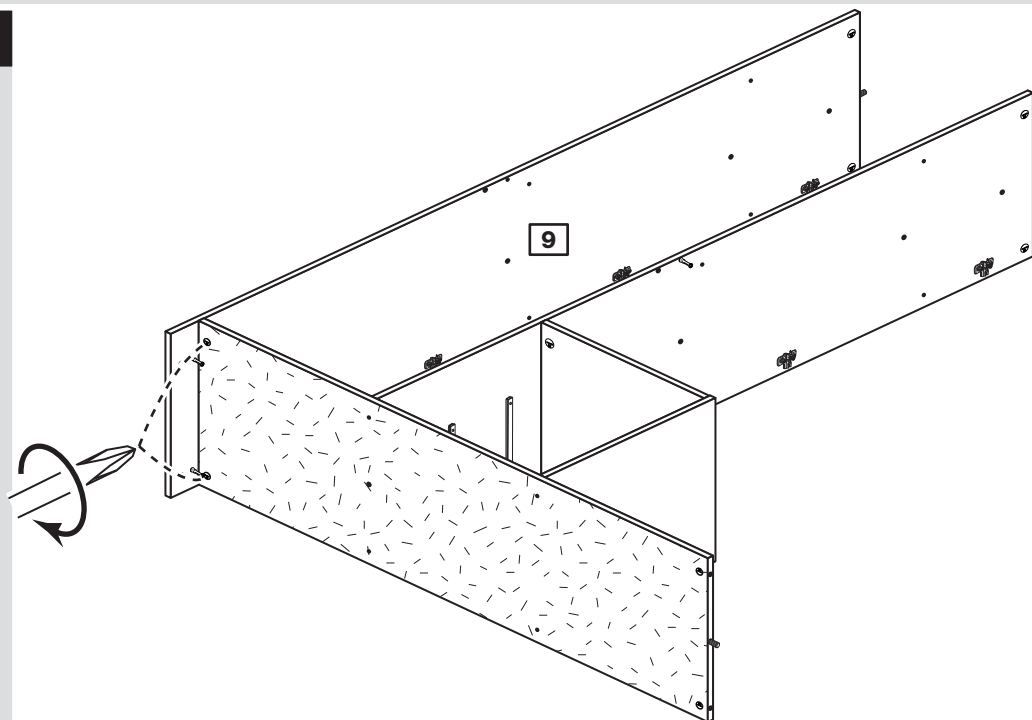

Step 18

Prepare the 2 plinths

Insert 2 large locking nuts **D** into each of the plinths **14**.

Tap 2 wooden dowels **A** into each of the plinths **14**.

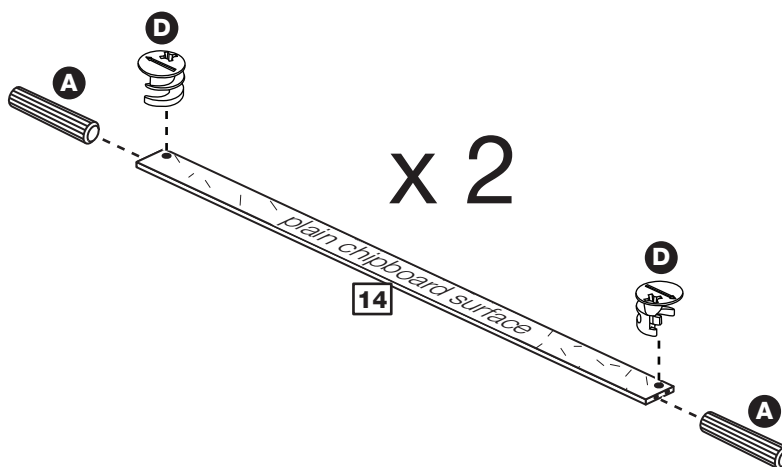

Step 19

Prepare the back rail

Insert 2 large locking nuts **D** into the back rail **12**.

Tap 2 wooden dowels **A** into the back rail **12**.

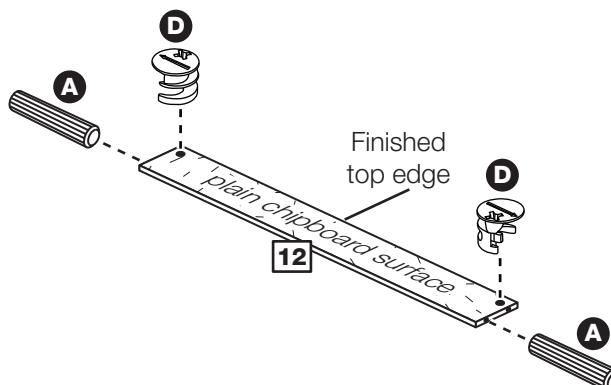

Assembly Instructions

Step 20

Fit the back rail and the plinths

Push the back rail **12** onto the divider **10**.

Use a screwdriver to tighten the large locking nut **D** fitted to the back rail **12**.

Push each plinth **14** onto the right side **9**.

Use a screwdriver to tighten the large locking nut **D** fitted to each plinth **14**.

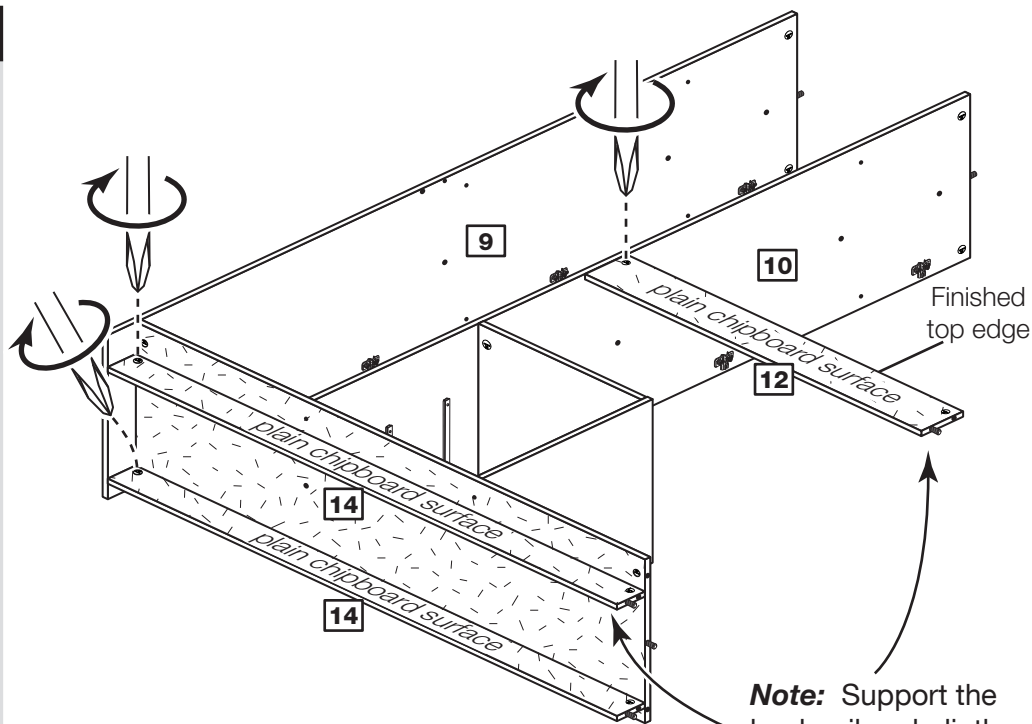

Note: Support the back rail and plinth until the left side has been fitted in the next step.

Step 21

Fit the left side

Push the left side **8** onto the base **7**, back rail **12** and the 2 plinths **14**.

Use a screwdriver to tighten the 5 large locking nuts **D** fitted to the base **7**, back rail **12** and plinths **14**.

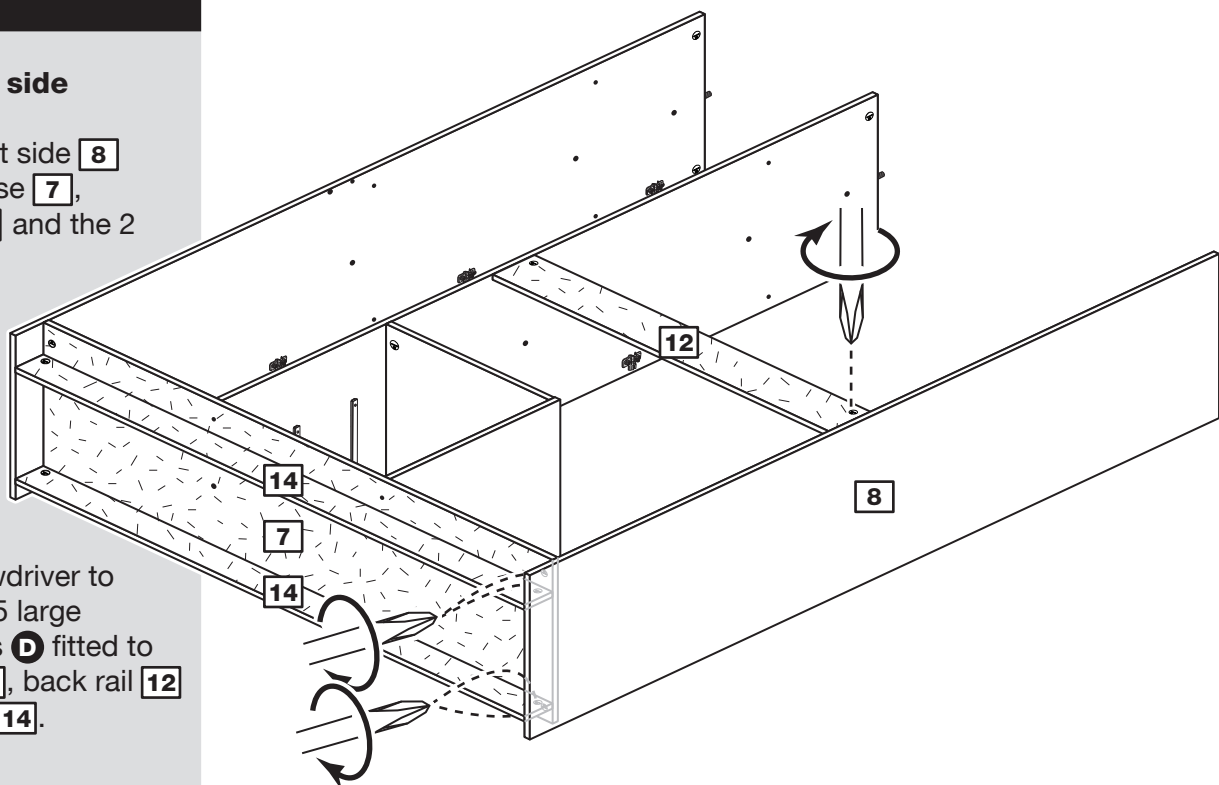

Assembly Instructions

Step 22

Prepare the top

Screw 6 metal dowels **B** into the top **6**.

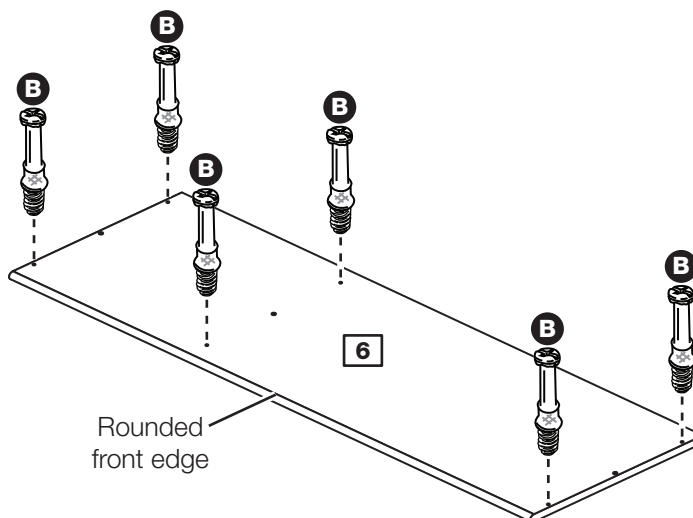

Step 23

Fit the top and plastic nails

Push the top **6** onto the assembly.

Use a screwdriver to tighten the 6 large locking nuts **D** fitted to the left side **8**, right side **9** and divider **10**.

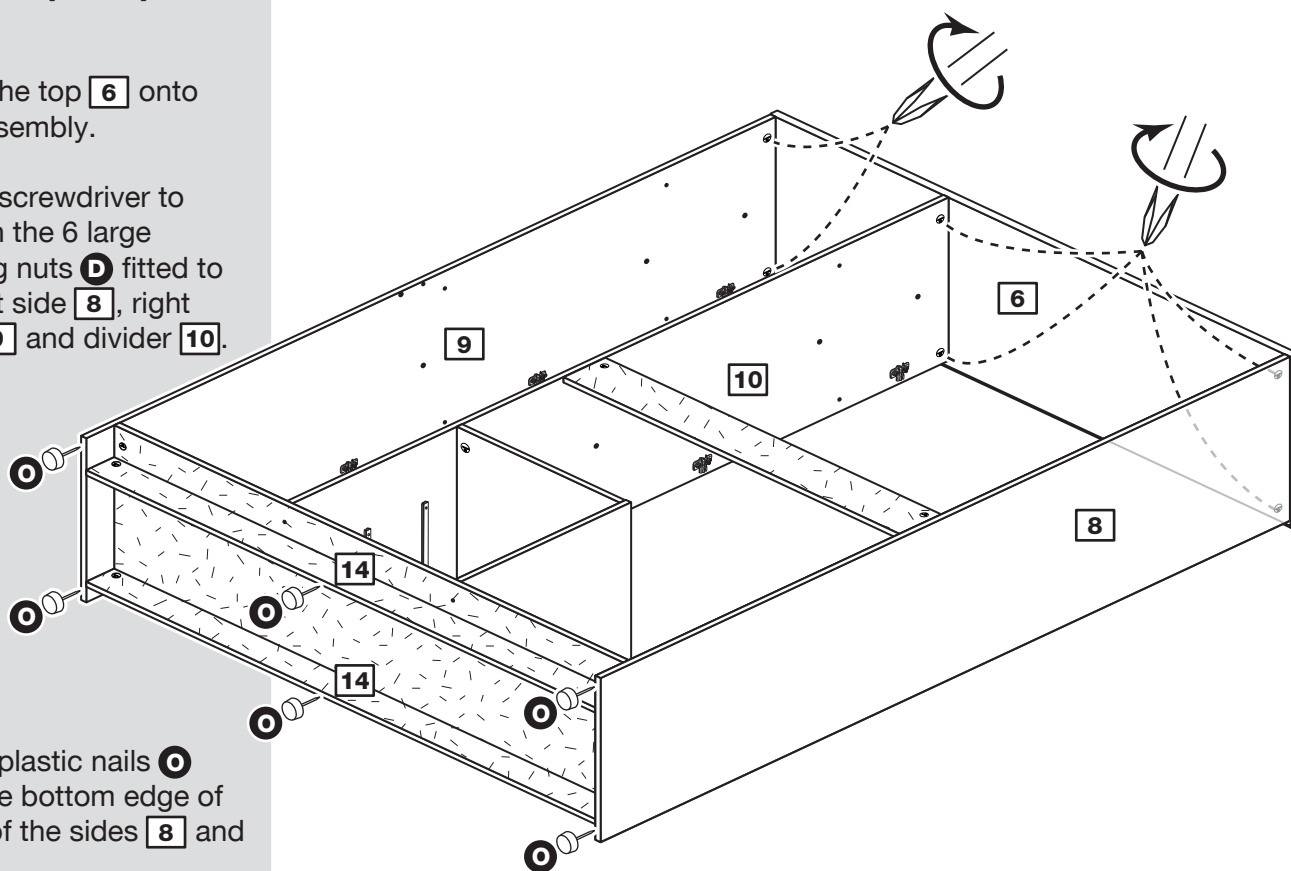

Tap 2 plastic nails **O** into the bottom edge of each of the sides **8** and **9**.

Tap 1 plastic nail **O** into the bottom edge of each plinth **14**.

Assembly Instructions

Step 24

Fit back panels

a: Square up the unit by making sure that measurement **x:x equals y:y**.

Place the small back **21** and large back **22**, coloured surface facing down, onto the unit as shown.

Make sure that the 2 backs are pushed up tight against each other and that they meet in the centre of the divider's back edge.

b: Nail **K** around the outside edges of the 2 backs.

Note: Do not nail where the 2 backs meet.

c: Push the nail screws **E** through the back holders **F** and tap them down between the small back **21** and large back **22** and into the back edge of the divider **10**.

Keep tapping the nail screws **E** in until the back holders **F** dig into the small and large back.

Stand the unit up for the next step.

a: The measurement from top corner X to bottom corner X must be equal to the measurement from top corner Y to bottom corner Y

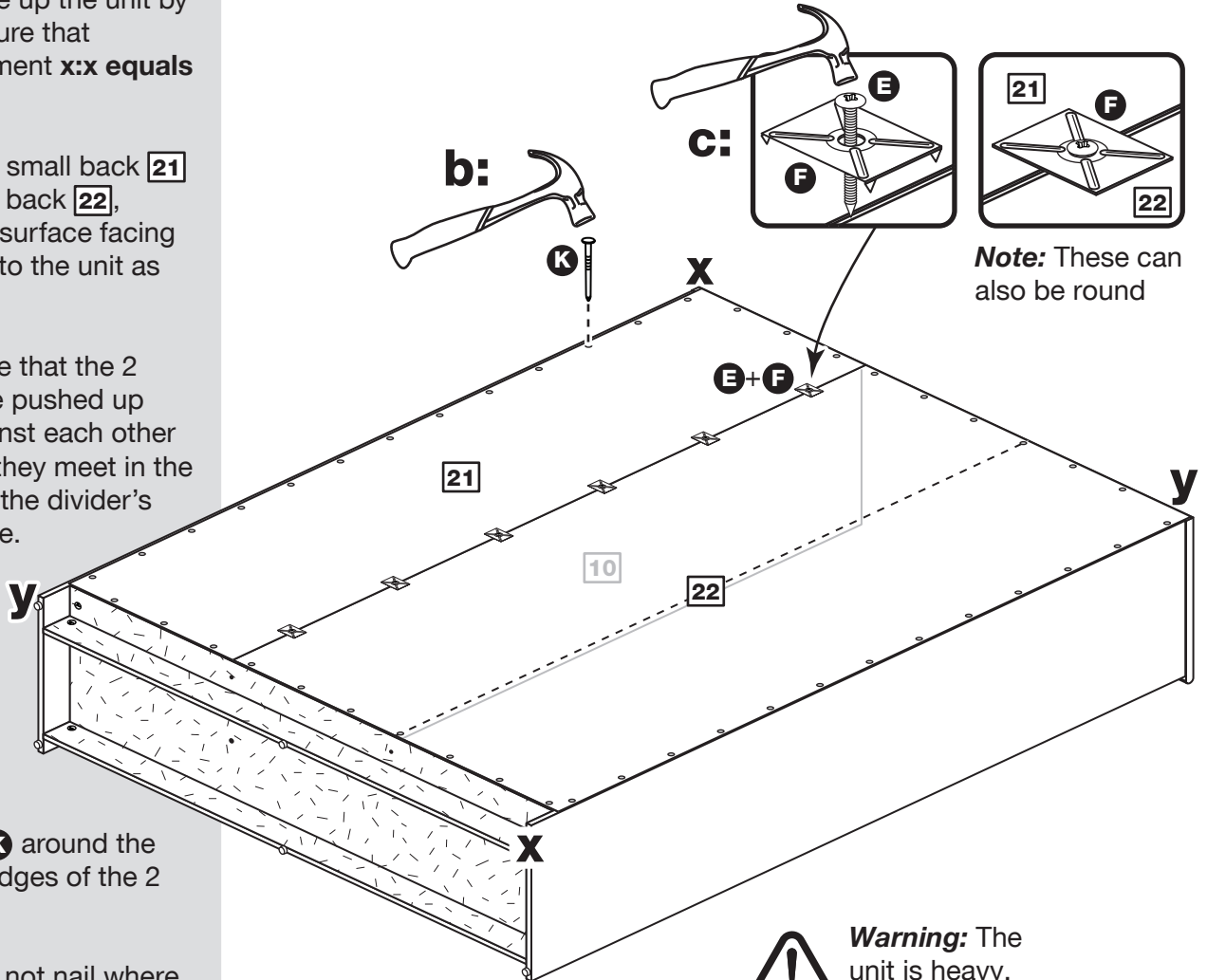

Note: These can also be round



Warning: The unit is heavy. Lift with care.

Note: If ever you need to take the backs off to dismantle the unit, the nail screws can be taken out using a screwdriver.

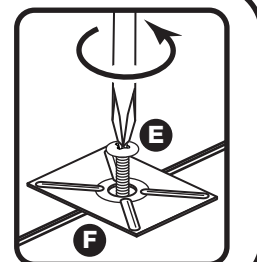

Assembly Instructions

Step 25

a: Fit the hanging rails

You can fit the 2 long hanging rails **19** and 2 short hanging rails **20** using any of the positions shown opposite.

Note: The short rail at position 4 is used for shoe storage.

Insert 2 rail holders **M** for each of the 4 rails and then secure them with screws **G**.

Push the hanging rails **19** and **20** down into the rail holders **M**.

b: Fit the drawers

Starting with the bottom drawer, slide both the runners **U** forward and locate the drawer sides **2** and **3** between them, lining up the holes in the drawer wrap with the 2nd 'threaded' holes in the runners **U**.

Working from the inside of the drawer, insert 2 screws **I** through the drawer sides and out into the 2nd threaded hole in the runner.

Note: Do not overtighten the screws **I**. If they catch on the runner you may need to loosen them slightly.

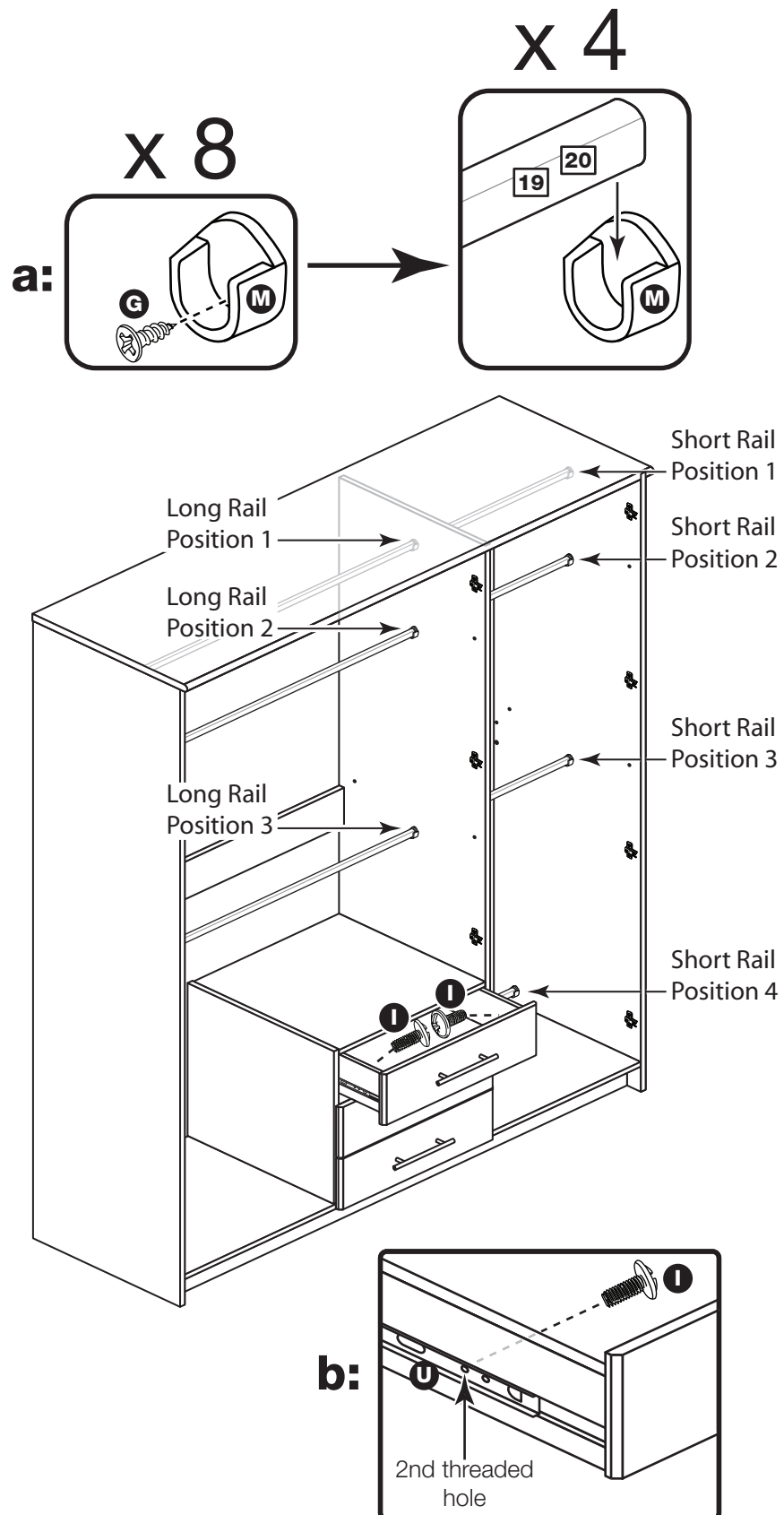

Assembly Instructions

Step 26

Fit the shelves

Insert 4 shelf studs **N** at position 1 or 2 for the large shelf **11** and the small shelf **13**.

Lower the large shelf **11** and the small shelf **13** down onto the shelf studs **N**.

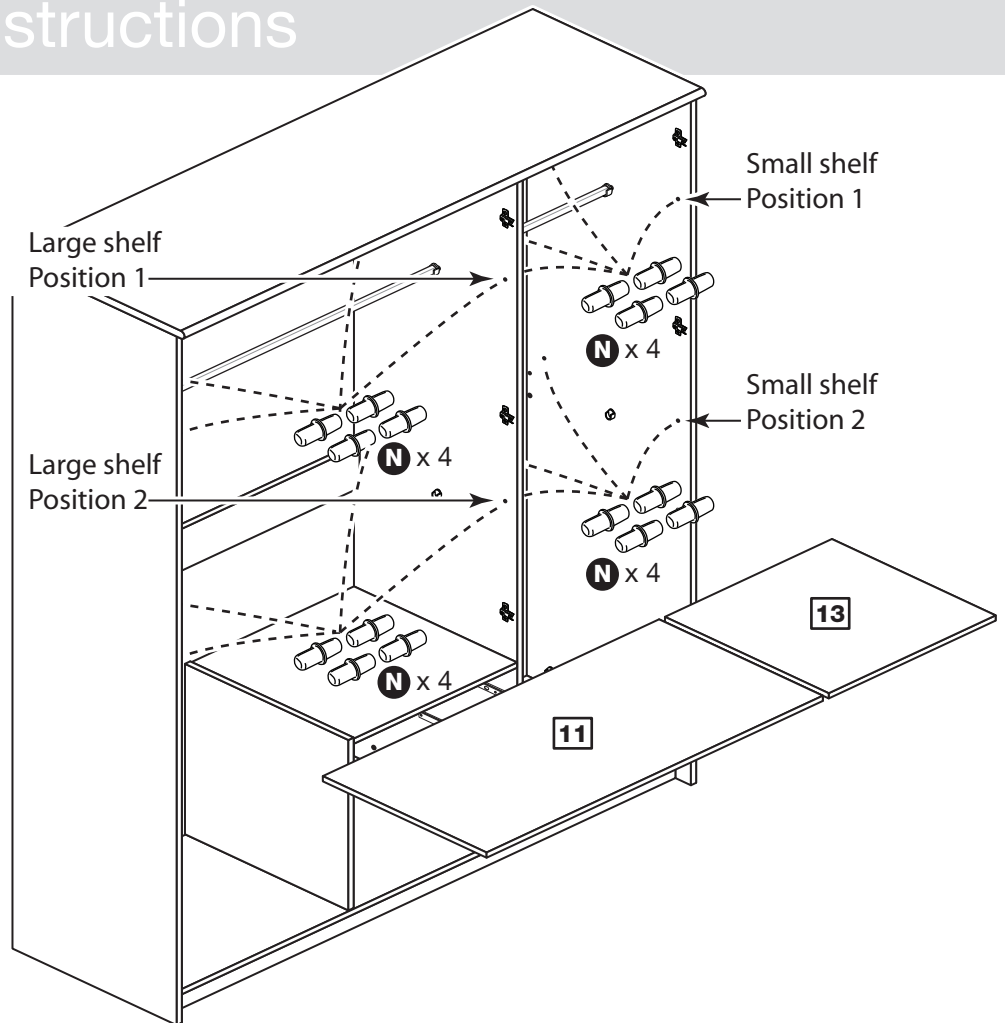

Step 27

Prepare the mirror door and the 2 plain doors

Push fit 3 hinges **T** into the mirror door **17**.

Secure each hinge with 2 screws **G**.

Note: Before securing with the screws, make sure that the hinges are positioned at 90 degrees with the edge of the door.

Push fit 4 hinges **T** into each of the plain doors **18**.

Secure each hinge with 2 screws **G**.

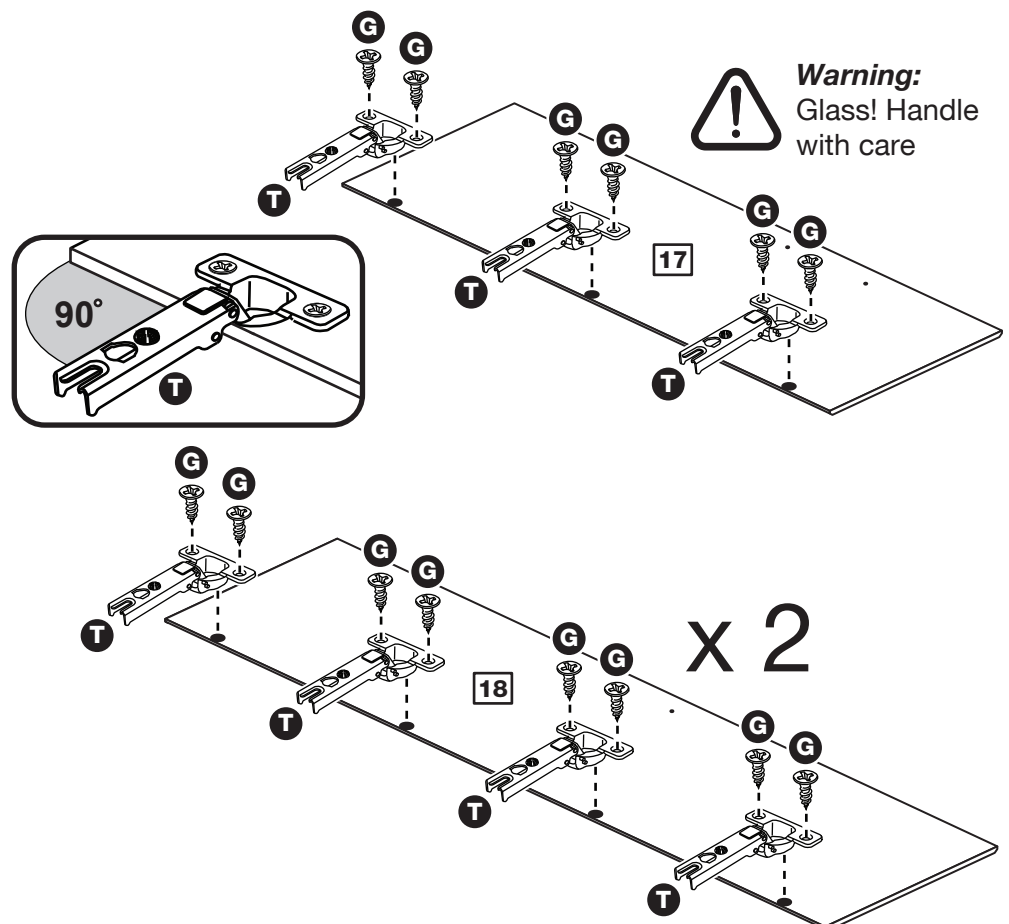

Assembly Instructions

Step 28

Fit doors and handles

Note: The easiest way to attach each door **17** and **18** is to fit the top hinge first, then align and fit the other hinges.

a: Push the hinge **T** onto the front part of the hinge plate **R**. The recess at the bottom of screw B goes into the slot in the hinge plate.

b: Keep the hinge **T** FLAT against the hinge plate **R** as you slide it across as far as it will go. Tighten screw A.

c: The hinge **T** must be flat against the hinge plate **R** prior to any adjustment.

d: The hinge **T** must NOT be AT AN ANGLE to the hinge plate **R** when assembled. This would indicate that the recess at the bottom of screw B had not located in the slot in the hinge plate and the hinge would not be secure. Remove the hinge from the hinge plate and then re-assemble being careful to follow instructions a-c.

e: Attach a handle **Sa** to each door **17** and **18** using 2 screws **Sb**.

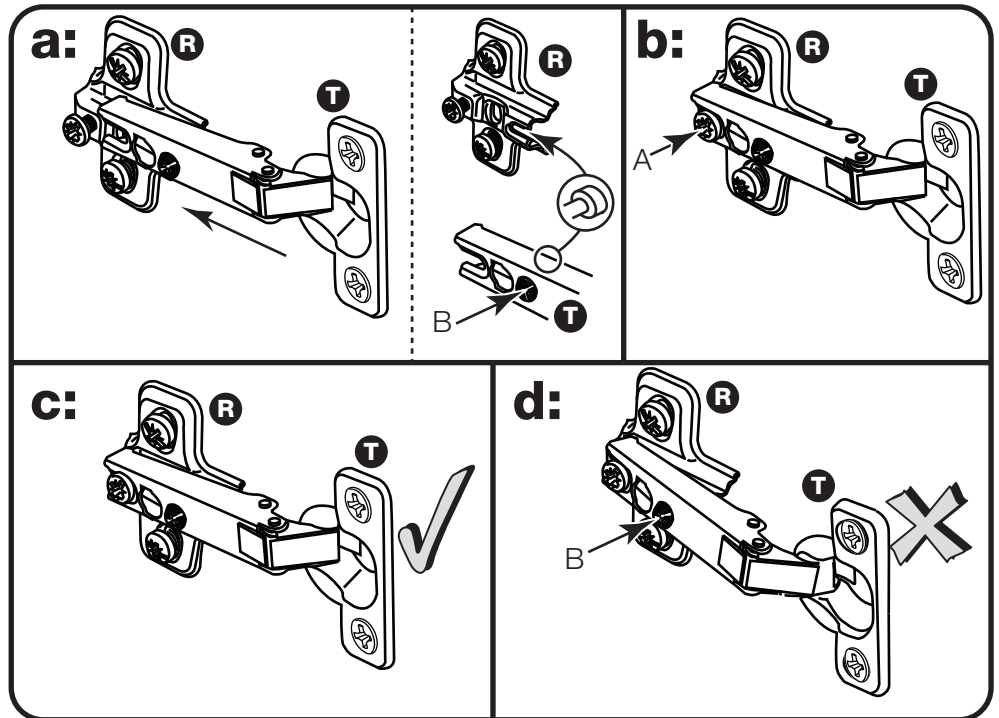

Warning:
Glass! Handle with care

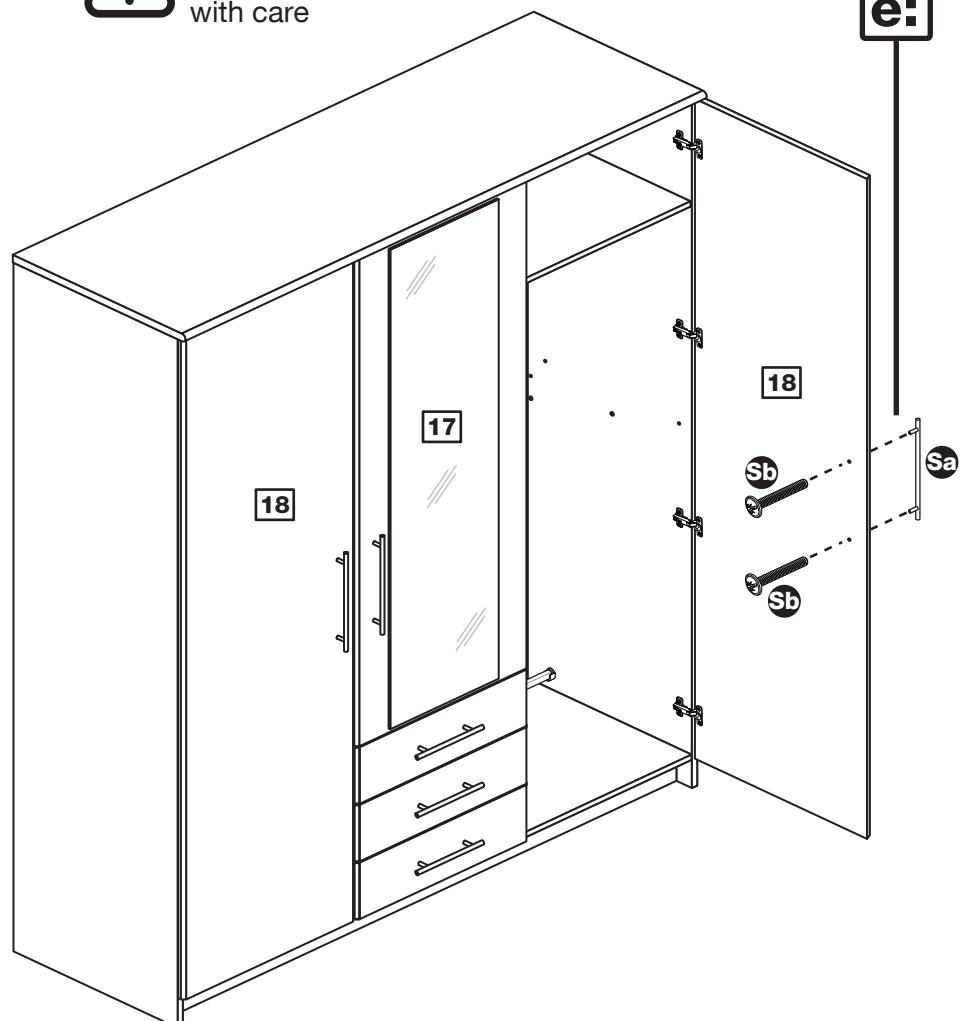

Assembly Instructions

Step 29

Adjust the doors if needed

a: Before adjusting the doors, use a spirit level to check the base (or top) of the unit is level, front-to-back and side-to-side in the 3 positions shown. Use suitable packing pieces (not supplied) to make the unit level BEFORE making any adjustment to the hinges, as shown.

b: Height adjustment.

Loosen screws A on hinge plates and move door up or down as required. Retighten screw A.

c: Forward and Back adjustment.

Loosen screw B on hinge plate and move door in or out as required. Retighten screw B.

d: Sideways adjustment.

To move door 'out' loosen screw C. To move door 'in' tighten screw C.

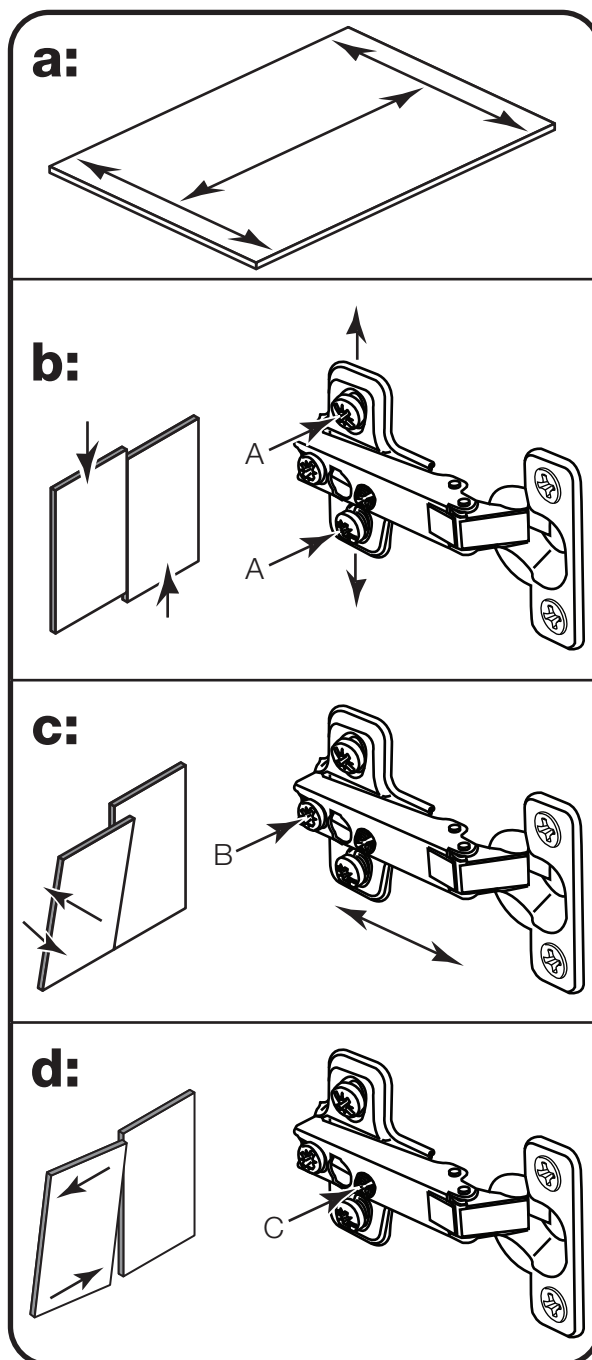

Assembly Instructions

Step 30

Fit the overbalance protector

To prevent possible overbalancing we recommend that this unit is secured to a suitable wall by use of the overbalance protector kit **Q** fitted to the unit or, an alternative fixing method of your choice.

Wall fixings are not supplied as they will need to suit the wall type.

Note: Take care when drilling the wall that you do not drill into any pipes, wires etc. If in doubt, consult an expert.

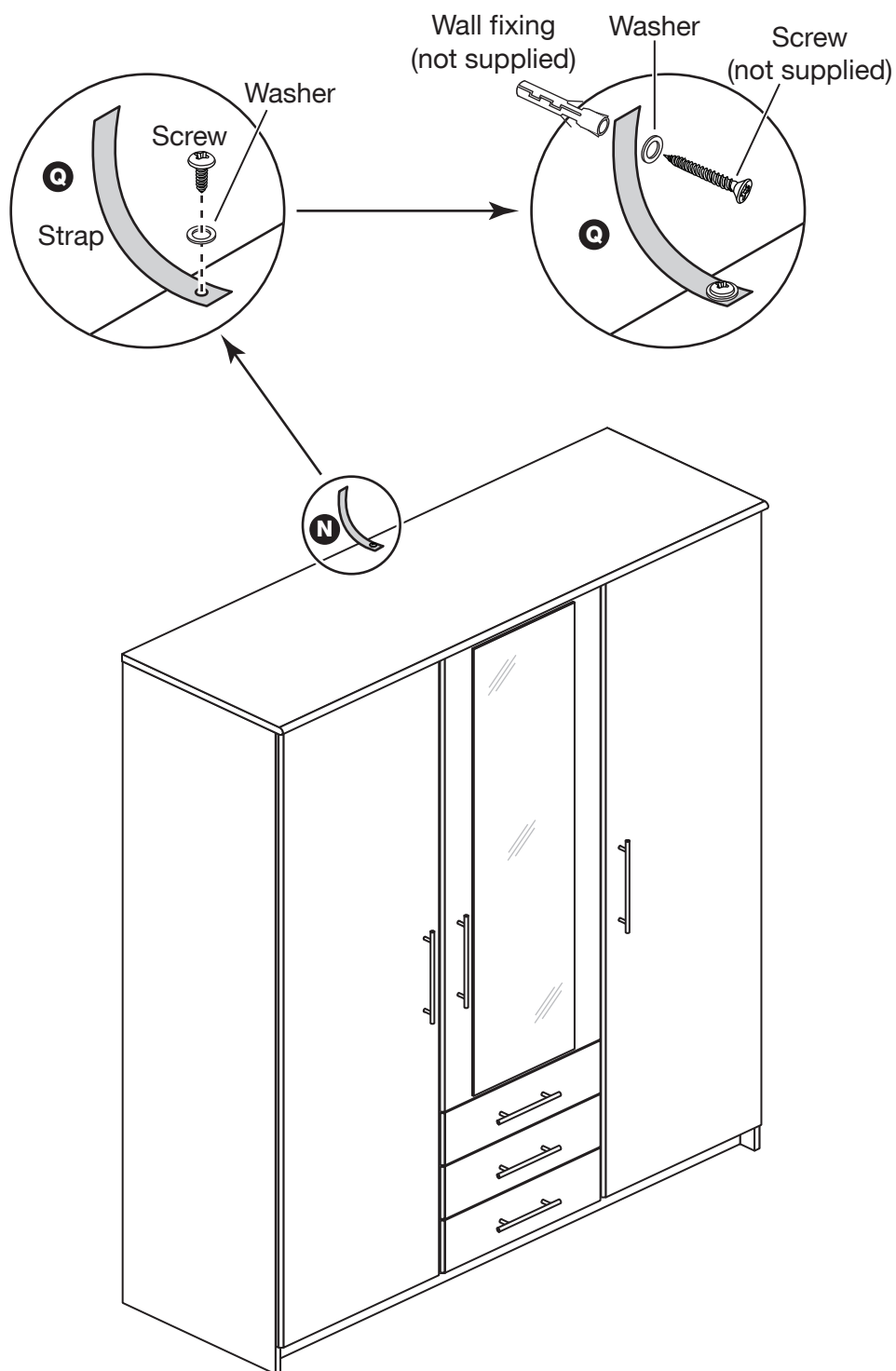

Assembly Instructions

Step 31

Assembly is complete



Warning: The unit is heavy. Lift with care.

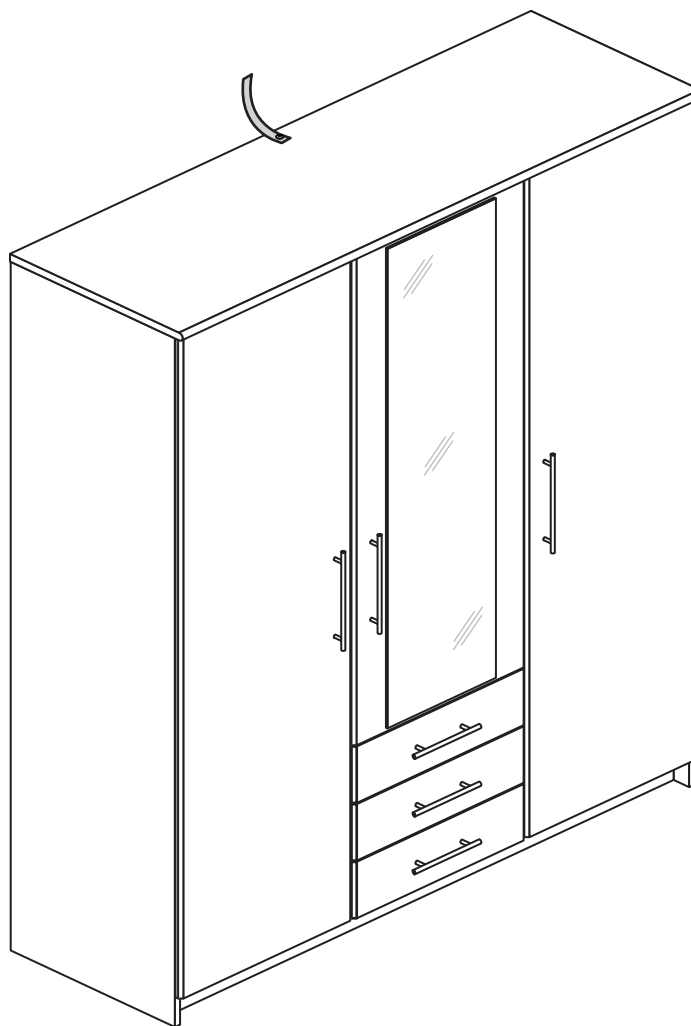

IMPORTANT INFORMATION ABOUT THIS PRODUCT

This product complies with the requirements of BS 7449:1991 and has been manufactured by DECORATIVE PANELS FURNITURE LTD, TEESIDE INDUSTRIAL ESTATE, THORNABY-ON-TEES, CLEVELAND, TS17 9LT.

The product code for this unit and the item code(s) for the glass components are listed in the Assembly Instructions along with a description of the type of glass used. All clear/tinted glass complies with the requirements of BS 6206 Class A. All mirrors comply with the requirements of BS 6206 Class C. If the glass component contained in this unit is chipped or broken consult the furniture manufacturer, retailer, or agent with regard to obtaining a manufacturing specification and shape for replacement glass quoting the unit description and batch number or date of manufacture.

Do not place very hot or very cold items against or in close proximity to glass surface(s) unless adequately thick insulating material is used to prevent such items coming in contact with the glass.

Do not strike the glass with hard or pointed items.

Do not sit or stand upon horizontal glass surfaces.

When cleaning glass panels use a damp cloth or leather with washing up liquid or soft soap if necessary - do not use washing powders or any other substance containing abrasives since these substances scratch glass.

If stated in the instruction leaflet, it is essential that this unit is fixed to a wall.

KEEP THESE INSTRUCTIONS FOR FUTURE USE

If you need help or have damaged or missing parts, call the **Customer Helpline: 08456 400800** and quote the reference numbers on the component pages.

Argos Ltd, 489-499 Avebury Boulevard, Central Milton Keynes, MK9 2NW