

2 Burner Gas BBQ with side burner

Assembly Instructions - Please keep for future reference

345/0901

307223



Dimensions

Width - 112cm

Depth - 52cm

Height - 96.5cm

Important - Please read this instructions fully before using the appliance

If you need help or have damaged or missing parts, call the **Customer Helpline: 03456 400800 (Argos)/ 03450 778888 (Homebase)**. Please visit the website www.argos.co.uk or www.homebase.co.uk for more information.

Safety and Care Advice

Important - Please read this instructions fully before using the appliance

- Assembly time: approx. 45 mins.
- Retain these instructions for future reference.
- Use outdoors only.
- Do not use the barbecue or store gas bottles below ground level. LP gas is heavier than air so if a leak occurs the gas will collect at a low level and could ignite in the presence of a flame or spark.
- For use with LPG bottled gas only. A suitable regulator must be used for butane, propane or mixes.
- Remove plastic wrap from any part before lighting.
- Do not use within 1m of any flammable structure or surface. Do not use under any combustible surface.
- LP gas cylinders should never be placed directly underneath the barbecue.
- LP gas cylinders should never be stored or used laid on their side, in the horizontal position. A leak would be very serious and liquid could enter the gas line with serious result.
- Never store gas bottles indoors.
- Do not move the appliance during use.
- Open the barbecue hood before lighting.
- Do not move the barbecue until it has completely cooled after use.
- This barbecue must not be left unattended when lit.
- The hood handle can become very hot. Grip only the centre of the handle. Always use oven gloves when cooking or carrying out any adjustments to the barbecue.
- Use purpose designed barbecue tools with long and heat resistant handles.
- Use caution when opening the hood, as hot steam inside is released upon opening.
- Warning: accessible parts may be very hot. Keep young children away.
- Turn off the gas supply at the gas cylinder after use.
- Never cover a barbecue until it has completely cooled.
- Use this barbecue only on a stable and flat surface.
- Before use this barbecue, perform a leak test. Thus is the only safe and sure way to detect any gas leaking from joints and connections of the barbecue after assembly.
- Leak test annually, and whenever the gas bottle is removed or replaced.
- Do not store flammable materials near this barbecue.
- Do not use aerosols near this barbecue.
- Failure to follow the manual's instructions could result in serious injury or damage.
- Do not modify the appliance. Modification of this barbecue may be dangerous, is not permitted and will nullify any warranty.
- This appliance must be kept away from flammable materials during use.
- All the parts sealed by the manufacturer or his agent shall not be manipulated by the user.
- If you have any queries regarding these instructions, contact your local dealer.

Gas and Regulator

This barbecue can use either propane or butane or propane/ butane mixed LPG (liquid petroleum gas) bottled gas. Propane bottles, will supply gas all year round, even on cold winter days. Butane bottles will supply sufficient gas in summer, but it may affect the performance of the barbecue and restrict the heat output available from the burners, particularly once the gas temperature starts to fall below +10°C. A spanner may be required to change gas bottles.

- The hose should hang freely with no bends, twisting, tension, folds, or kinks that could obstruct free flow of gas. Always inspect the hose for cuts, cracks, or excessive wear before use.
- Apart from the connection point, no part of the hose should touch any hot barbecue parts. If the hose shows any sign of damage it must be replaced with a hose suitable for use with LP gas which meets the national standards for the country of use.
- A suitable hose must comply with BS3212, and the length should not exceed 1.5 metres.

Safety and Care Advice

For optimal performance, we suggest to use a 5-15kg gas bottle. The maximum dimension of the gas bottle is dia 31.5cm and height 58cm.

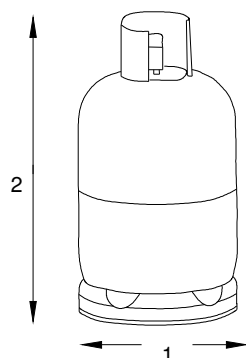

Key
1= maximum diameter
2= maximum height

Never mount the gas bottle under the barbecue on the base shelf as this could result in serious injury to the user, other people and/or property. **Always place the gas bottle at the side of the appliance. The gas bottle should be sited as far away from the appliance as possible without straining the hose.** This appliance is only suitable for use with low-pressure butane or propane gas and fitted with the appropriate low-pressure regulator via a flexible hose. The hose should be secured to the regulator and the appliance with hose clips/nut. This barbecue is set to operate a 28-30 mbar regulator with butane gas or a 37mbar regulator with propane gas. Use a suitable regulator certified to EN16129. Please consult your LPG dealer for information regarding a suitable regulator for the gas cylinder.

Installation

Selecting a Location

This barbecue is for outdoor use only and should be placed in a well-ventilated area, and on a safe and even surface. Never place your barbecue below ground level. Take care to ensure that **the barbecue must be used on incombustible floor**. The sides of the barbecue should NEVER be closer than 1 metre from any combustible surface, including trees and fences and make sure that there are no heat sources near the barbecue (cigarettes, open flames, spark etc.). Keep this barbecue away from any flammable materials!

Precautions

Do not obstruct any ventilation openings in the barbecue body. Position the gas bottle on level ground next to the barbecue and safely away from any source of heat. Should you need to install or change the gas bottle, confirm that the barbecue is switched off, and that there are no sources of ignition (cigarettes, open flame, sparks, etc.) near before proceeding.

Fixing a Regulator to the Gas Bottle

Confirm all barbecue control knobs are in the off position. Connect the regulator to the gas bottle according to your regulator and bottle dealer's instructions.

Leak Testing (Always perform a leak test in a well-ventilated area)

Confirm all control knobs are in the off position. Turn the gas on / open the gas control valve on the gas bottle or regulator. Check for leaks by brushing a solution of ½ water and ½ liquid detergent / soap over all the gas system joints, including gas bottle valve connections, hose connections, and regulator connections. NEVER USE AN OPEN FLAME to test for leaks at any time. If bubbles form over any of the joints there is a leak. Turn off the gas supply at the gas bottle. Retighten all joints. Repeat test. If bubbles form again do not use the barbecue and contact your local distributor for assistance. Always wipe the mixed solution (½ water and ½ liquid detergent / soap) from all joints and connections after leak testing.

Safety and Care Advice

Operation

Warning

- Before proceeding, make certain that you understand the ***IMPORTANT INFORMATION*** section of this manual.
- Your barbecue is not designed to be used with more than 50% of the cooking area as a solid plate — this includes baking dishes. Full coverage will cause excessive build-up of heat and damage the barbecue. This is not covered by warranty.

Preparation Before Cooking

To prevent foods from sticking to the cooking surface, please use a long handled brush to apply a light coat of cooking or vegetable oil before each barbecuing session. (Note: When cooking for the first time, paint colours may change slightly as a result. This is normal and should be expected.) During use, the protective coating may come off the cooking surface. This is normal and is not harmful. Line the drip pan with aluminium foil. This will make cleanup easy.

Lighting the Main Burner

- Open the barbecue hood.
- Ensure all knobs are in the off position. Open the gas control valve on the gas bottle or regulator.
- Push in and turn the control knob to the Max position. Press the ignition button rapidly several times until left or right portion of the burner is lit. If burner fails to ignite, turn control knob to the off position and turn gas off at the bottle or regulator. Wait five minutes, then repeat the above steps. After successful lighting of one side, ignite the remaining portion of the burner. If the burner fails to ignite after following above procedure, turn all the knobs to the off position. Close the gas valve on the gas bottle. Wait 5 minutes, then repeat the above steps. If the barbecue still fails to light, please refer to the manual ignition instruction in the section below.
- After ignition, the burner should be burned at the high position for 3-5 minutes in order to preheat the barbecue. This process should be done before every cooking session. The hood (where applicable) should be open during preheating.
- After completion of preheating, the burner should normally be turned down to a lower position for best cooking results.

Manual Ignition Instruction for Main Burner

- Insert lit match through the match-lighting hole at the side or bottom of the barbecue body.
- Push in and turn the control knob anti-clockwise to the max position.
- After the left or right portion of the burner is lit, light the remaining portion of the burner.
- If burner fails to ignite, contact your local dealer for assistance.
- After ignition, the burner should be burned at the max position for 3-5 minutes in order to preheat the barbecue. This process should be done before every cooking session. The hood (where applicable) should be open during preheating.
- After completion of preheating, the burner should normally be turned down to a lower position for best cooking results.

Lighting the Side Burner

- Keep side burner free.
- Set the control knob to off and turn on the gas supply.
- Push in and turn the control knob anti-clockwise to max position.
- Push the ignition button several times and the burner should ignite.
- If the burner fails to ignite after above procedure, turn the knob to the off position and close the gas valve. Wait 5 minutes and then repeat the above steps. If the barbecue still fails to light, please refer to the manual ignition instruction in the section below.

Safety and Care Advice

Manual Ignition Instruction for Side Burner

- Set the control knob to the off position.
- Apply a lit match on the gap to burner ports.
- Push and turn the control knob anti-clockwise to max position and the burner should ignite. If the burner fails to ignite, contact your local dealer for assistance.

Grill Cooking

The burners heat up the flame tamer underneath the grill, which in turn heats the food on the grill. The natural food juices produced during cooking fall onto the hot flame tamer below and vaporise. The subsequent rising smoke bastes the food, as it travels upwards, imparting that unique barbecued flavor.

Roasting Hood Cooking

Barbecues equipped with a roasting hood give the option to form an 'oven' for roasting or baking food, such as joints of meat or whole chickens, etc. More even cooking of food will actually be achieved by using the barbecue with the hood down. However, this should only be done with the burners on low.

For best results, place the food you wish to bake or roast on a metal baking tray and set it on one side of the cooking grill.

Turn the burner directly under the food to the OFF position and turn all other burners to a LOW to MEDIUM position.

Close the hood to cook the food 'indirectly'. Avoid lifting the hood unnecessarily as heat is lost every time the hood is opened. If the hood is opened during cooking please allow extra time for the barbecue to regain its temperature and complete the cooking. Use the temperature gauge (if applicable) to monitor the heat of the barbecue.

If the internal heat becomes too high, turn the burners down to the low position. It is not necessary or advisable to have all of the burners on high when the hood is closed.

DO NOT ALLOW YOUR BARBECUE TO OVERHEAT. Take care when opening the hood as hot steam can be released on opening.

Flare-Up Control *Very Important Notice*

Flare-ups occur when meat is barbecued, and its fat and juices fall upon the hot flame tamer. Smoke of course helps give food its barbecued flavour, but it is best to avoid excessive flare-up to prevent food being burned. To control flare-ups, it is ABSOLUTELY ESSENTIAL to trim away excess fat from meat and poultry before grilling, use cooking sauces and marinades sparingly and try to avoid very cheap cuts of meat or meat products as these tend to have a high fat and water content. Also, the burners should always be placed on the low setting during cooking.

When flare-ups do occur, they can usually be extinguished by applying baking soda or salt directly onto the flame tamer. Always protect your hands when handling anything near the cooking surface of the barbecue and take care to protect yourself from the flames.

If a fat fire occurs, please see the instructions given below.

Fat Fires

Empty and clean the drip tray, of food debris after each cooking session. If the barbecue is to be used for large gatherings, it will be necessary to turn off and cool the barbecue every two hours to remove food debris from the drip tray, and clean it out. The time between cleaning may need to be reduced if very fatty foods or cheap meat products are being cooked. Failure to do this may result in a fat fire, which may cause injury and could seriously damage the barbecue.

Safety and Care Advice

In the event of a fat fire:

- If safe to do so, turn all control knobs to the 'off' position.
- Turn off the gas supply at the gas bottle.
- Keep everyone at a safe distance from the barbecue and wait until the fire has burnt out.
- Do not close the hood or lid of the barbecue.
- NEVER DOUSE A BARBECUE WITH WATER. IF AN EXTINGUISHER IS USED, IT SHOULD BE A POWDER TYPE.
- DO NOT REMOVE THE DRIP TRAY.
- If the fire does not seem to be abating or appears to be worsening, contact your local Fire Brigade for assistance.

End of Cooking Session

After each cooking session, turn the barbecue burners to the "high" position and burn for 5 minutes. This procedure will burn off cooking residue, thus making cleaning easier. Make sure the hood is open during this process.

Turning Off Your Barbecue

When you have finished using your barbecue, turn all the control valves fully clockwise to the "Off" position, then switch off the gas supply at the bottle.

Wait until the barbecue is sufficiently cool before closing the hood or lid.

Care and Maintenance

Regularly clean your barbecue between uses and especially after extended periods of storage. Ensure the barbecue and its components are sufficiently cool before cleaning. Do not leave the barbecue exposed to outside weather conditions or stored in damp, moist areas.

- Never douse the barbecue with water when its surfaces are hot.
- Never handle hot parts with unprotected hands.

In order to extend the life and maintain the condition of your barbecue, we strongly recommend that the unit be covered when left outside for any length of time, especially during the winter months

Even when your barbecue is covered for its protection, it must be inspected on a regular basis as damp or condensation can form which may result in damage to the barbecue. It may be necessary to dry the barbecue and the inside of the cover. It is possible for mould to grow on any fat remaining on parts of the barbecue. This should be cleaned off smooth surfaces with hot soapy water.

Any rust that is found that does not come into contact with the food should be treated with a rust inhibitor and painted with barbecue paint or a heat resistant paint. A chrome cleaner may be used on chrome parts if required. To prevent rusting, wipe chrome plated parts with cooking oil after rinsing and drying.

Cooking Surfaces

When the barbecue has cooled, clean with hot soapy water. To remove any food residue, use a mild cream cleaner on a non-abrasive pad. Do not use scouring pads or powders as they can permanently damage the finish. Rinse well and dry thoroughly. Due to the weight of the cooking surfaces, we do not recommend cleaning in a dishwasher.

It is quite normal for surface rust to be present on the cooking surface. If rust appears between uses or in storage, clean with a soft brass wire brush. Be careful not to damage the cooking surface, re-oil and cure.

Burner

Provided that they are operating correctly, in normal usage, burning off the residue after cooking will keep

Safety and Care Advice

the burners clean.

The burners should be removed and cleaned annually, or whenever heavy build-up is found, to ensure that there are no signs of blockage (debris, insects) in either the burner portholes or the primary air inlet of the burners. Use a pipe cleaner to clear obstructions.

When refitting the burners, be careful to check that the neck of the burner fits over the valve outlet. It is quite normal for surface rust to be present on the burners. If rust appears between uses or in storage, clean with a soft brass wire brush.

Flame Tamer

Remove any food residue from the flame tamer surface with a plastic or wooden scraper or brass wire brush.

Do not use a steel scraper or wire brush. Clean with hot soapy water and rinse well.

Drip Tray

After every use, empty and clean the drip tray of any fat or food particles, using a plastic or wooden scraper if necessary.

Failure to keep it clean, and excessive build up can result in a fat fire. This can be hazardous and severely damage the barbecue. This is not a fault in the barbecue and is therefore not covered by the terms of the warranty. If required, the tray can be washed in hot soapy water.

Barbecue Body

Regularly remove excess grease or fat from the barbecue body using a cloth wrung out in hot soapy water and dry thoroughly. Excess fat and food debris can be removed from inside the body using a soft plastic or wooden scraper. It is not necessary to remove all the grease from the body. If you need to clean fully, use hot soapy water and a cloth, or nylon-bristled brush only. Do not use abrasives. Remove cooking surfaces and burners before full cleaning. Do not immerse the gas controls or manifold in water. Check burner operation after carefully refitting into body.

A stainless steel cleaner may be used on stainless steel parts if required.

Whenever a barbecue is being assembled for the first time or its burners are being cleaned, make sure each gas valve tip goes into the burner venturi tube completely during the assemble or re-assemble process.

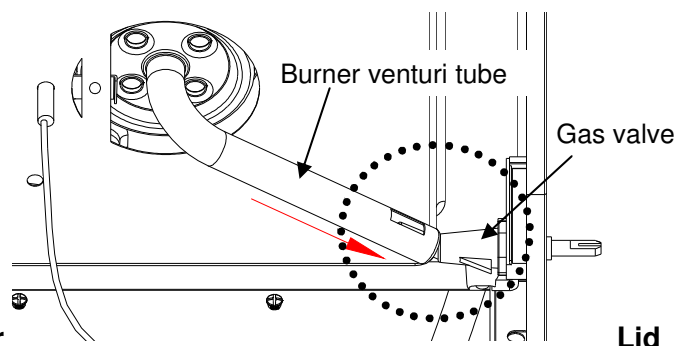

Barbecue Hood or

Use a non-abrasive cloth or pad and clean with hot, soapy water. Do not use scouring pads or powders as they can permanently damage the finish.

Trolley

Wipe with a cloth wrung out in hot soapy water and dry.

Safety and Care Advice

Fixings

All screws and bolts, etc. should be checked and tightened on a regular basis.

Storage

Ensure the barbecue is properly cooled before covering or storing. Store your barbecue in a cool dry place. It must be inspected on a regular basis as damp or condensation can form which may result in damage to the barbecue. It may be necessary to dry the barbecue and the inside of the cover if used.

Mould can grow under these conditions and should be cleaned and treated if required. Any rust that is found that does not come into contact with the food should be treated with a rust inhibitor and painted with barbecue paint or a heat resistant paint.

Cooking grills should be coated with cooking oil.

Cover the burners with aluminum foil in order to prevent insects or other debris from obstructing the burner holes.

If the barbecue is to be stored indoors, the gas bottle must be disconnected and left outside. The gas bottle should always be stored outside, in a dry, well-ventilated area, away from any sources of heat or ignition. Do not let children tamper with the bottle.

When using the barbecue after extended periods of storage follow the cleaning procedures.

Carbon Monoxide Hazard

<p>⚠ WARNING</p> 	<p>CARBON MONOXIDE HAZARD</p> <p>Danger of carbon monoxide poisoning - NEVER light this product or let it smoulder or cool down in confined spaces.</p>
-------------------------------------------------------------------------------------------------------------	----------------------------------------------------------------------------------------------------------------------------------------------------------------

Note: if required the next page can be cut out and used as reference throughout the assembly. Keep this page with these instructions for future reference.

Components - Parts

If you have damaged or missing components, call the **Customer Helpline: 03456 400800 (Argos)/ 03450 778888 (Homebase).**

Please check you have all the panels listed below

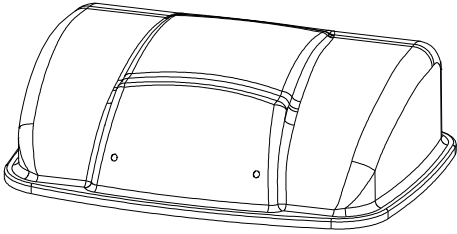

1 Lid x1

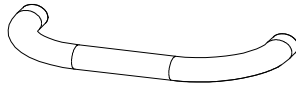

2 Lid handle x1

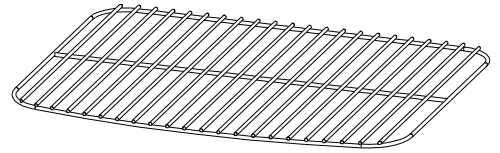

3 Cooking grill x1



4 Heat tent x1

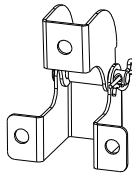

5 Hinge x 2

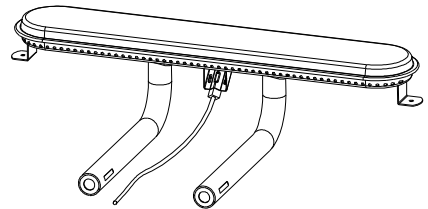

6 Burner x 1

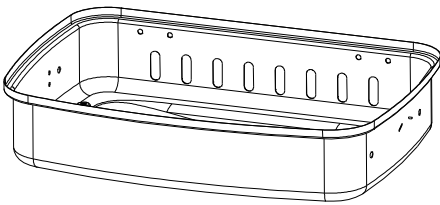

7 Firebowl x1

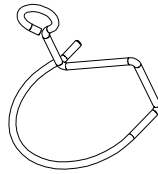

8 Grease cup hanger x 1

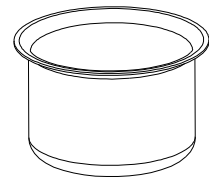

9 Grease cup x1

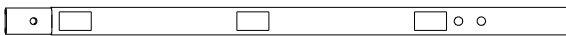

10 Right front leg x 1



11 Right rear leg x1

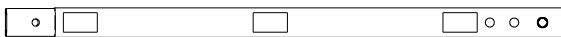

12 Left front leg x 1

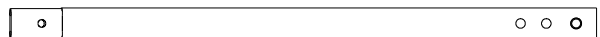

13 Left rear leg x1



Components - Parts

Please check you have all the panels listed below

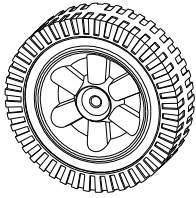

14 Wheel x 2

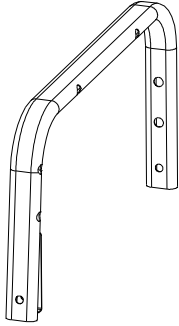

15 Left upper support x 1

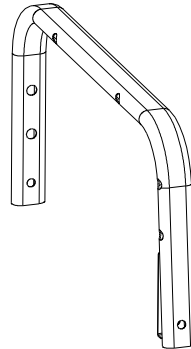

16 Right upper support x 1

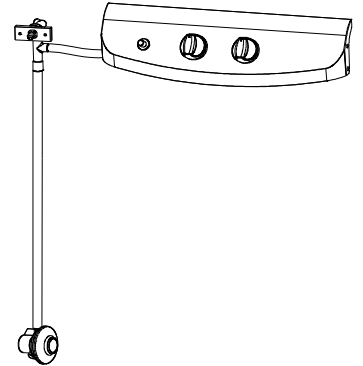

17 Control panel assembly x 1

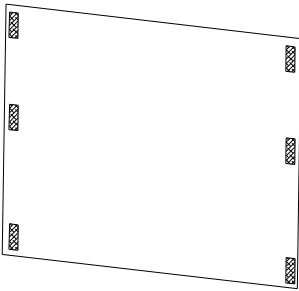

18 Front canvas x1

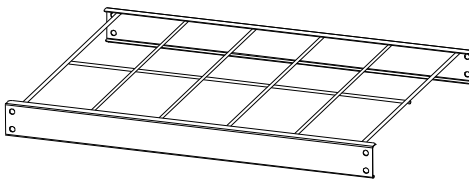

19 Bottom shelf x1

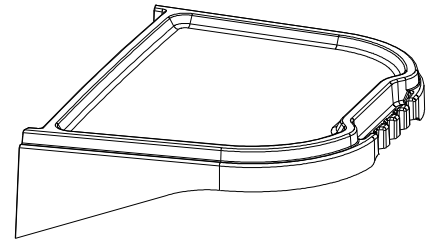

20 Side table x1

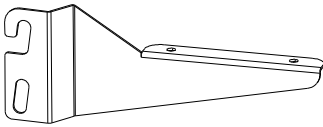

21 Side table front support x1

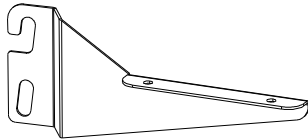

22 Side table rear support x1

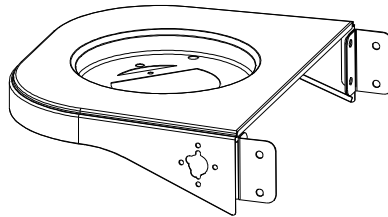

23 Side burner assembly x1

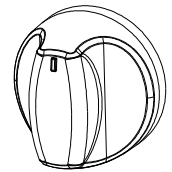

24 Side burner knob x 1

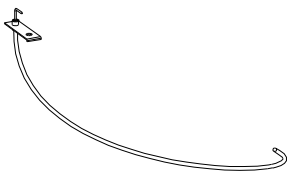

25 Side burner electrode x 1

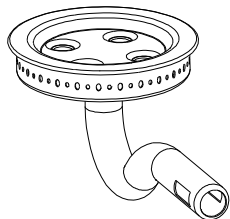

26 Side burner x 1

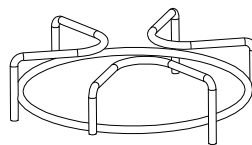

27 Side burner grate x 1

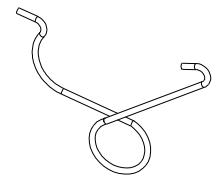





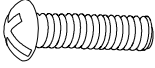
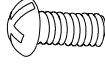

28 Venturi clip x 1

Components - Fittings

Please check you have all the panels listed below

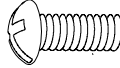
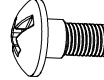
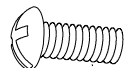
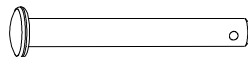
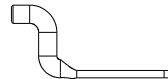
Note: The quantities below are the correct amount to complete the assembly.

<p>A</p>  <p>20mm Bolt x 8</p>	<p>B</p>  <p>12mm Bolt x 16</p>	<p>C</p>  <p>10mm screw x 6</p>	<p>D</p>  <p>M4 nut x 2</p>
<p>E</p>  <p>Washer x 2</p>	<p>F</p>  <p>M6 nut x 4</p>	<p>G</p>  <p>8mm Bolt x 8</p>	<p>H</p>  <p>15mm Shoulder bolt x 4</p>
<p>I</p>  <p>8mm Bolt x 3</p>	<p>J</p>  <p>Axle x 2</p>	<p>K</p>  <p>Heat tent support x 1</p>	<p>L</p>  <p>R-pin x 2</p>
<p>M</p>  <p>M5 nut x 6</p>			

Tool required

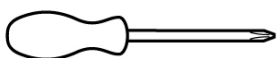

Philips screwdriver



Small hammer

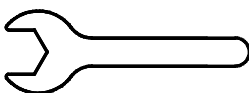

Wrench
(Do not provided in this product)



Ruler/ tape measure

Ruler - Use this ruler to help correctly identify the screws

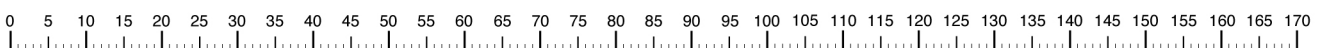

Assembly Instructions

Step 1

Fix the left front leg **12** and left rear leg **13** on the bottom shelf **19** using 12mm bolts **B**.

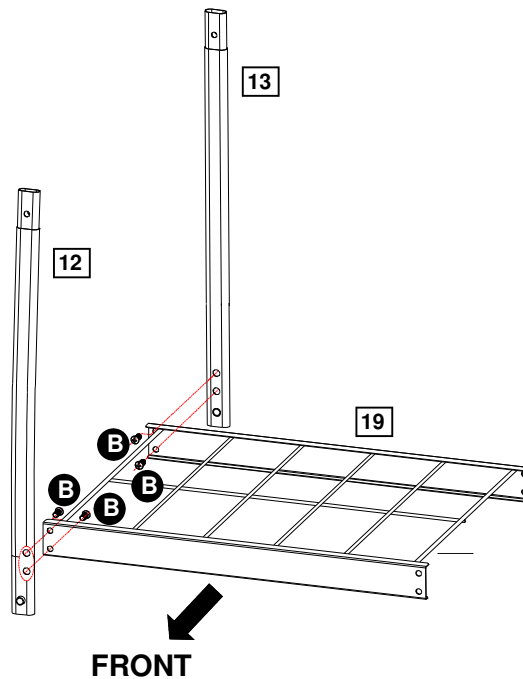

Step 2

Fix the right front leg **10** and left rear leg **11** on the bottom shelf **19** using 12mm bolts **B**.

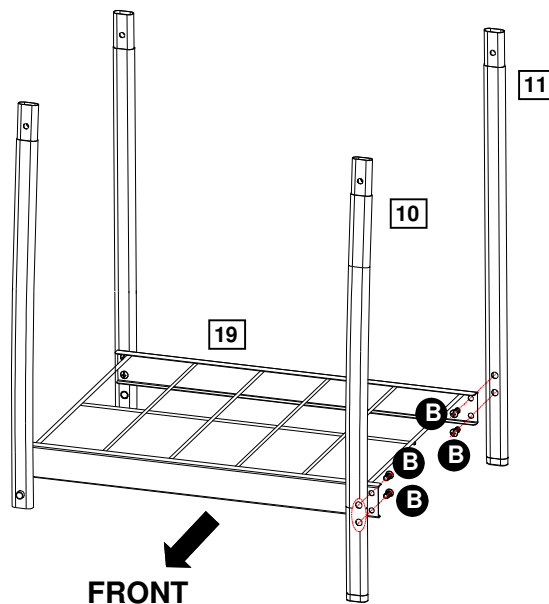

Assembly Instructions

Step 3

Install the wheels **14** to the left front leg **12** and left rear leg **13** using the axles **J**.

Then fix the axles **J** by R pins **L**.

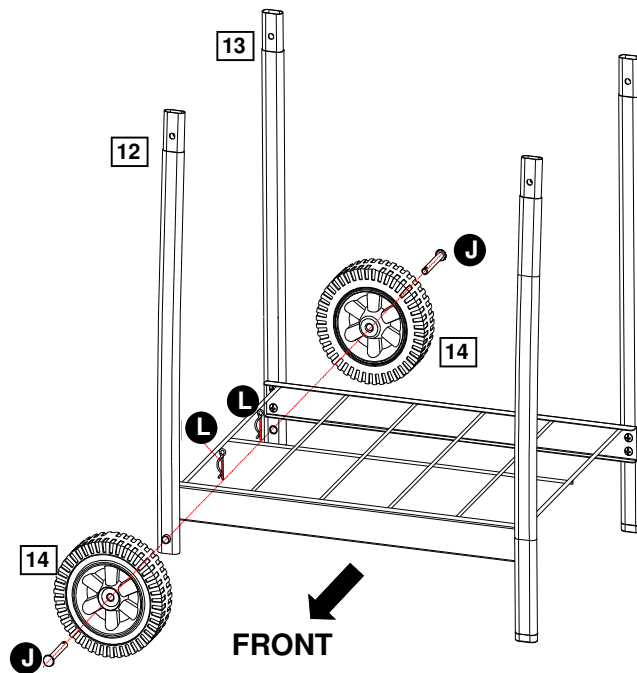

Step 4

Connect the left upper support **15** with the left front leg **12** and left rear leg **13** using 20mm bolts **A** and M6 nuts **F**.

Repeat the same connection of the right upper support **16** with the right front leg **10** and right rear leg **11** using 20mm bolts **A** and M6 nuts **F**.

Fix the bolts tightly by the screwdriver.

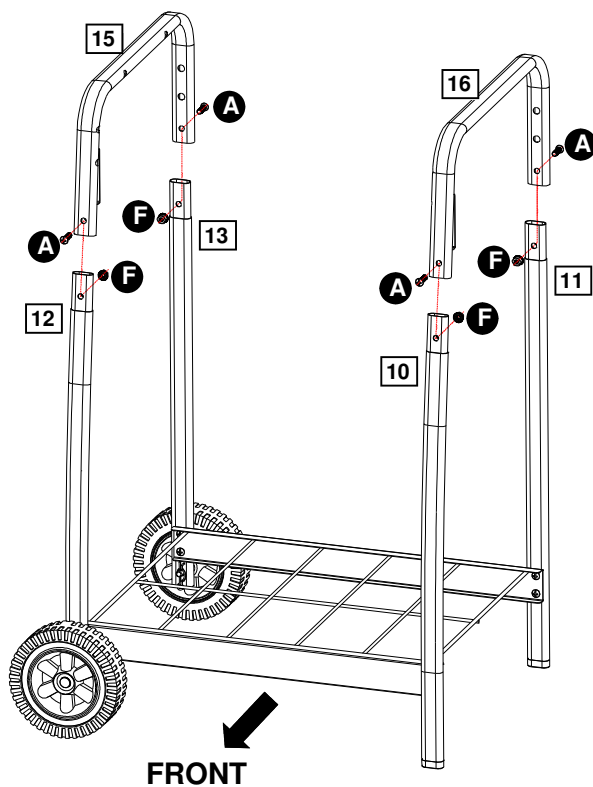

Assembly Instructions

Step 5

Fix the control panel assembly **17** on the left upper support **15** and right upper support **16** using 12mm bolts **B**.

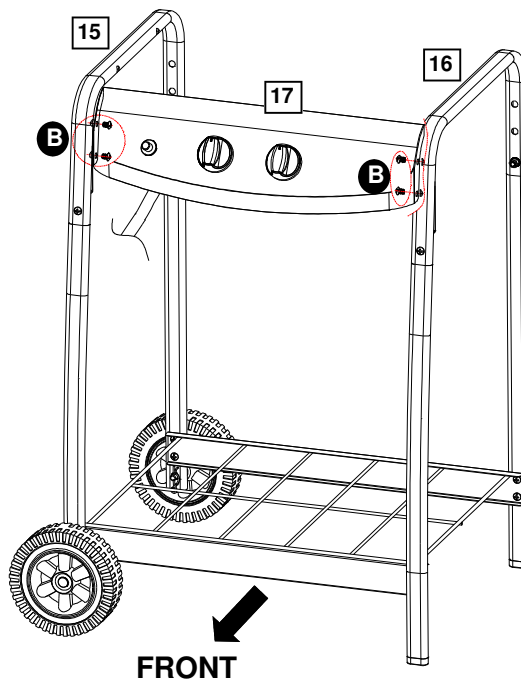

Step 6

Fix the heat tent support **K** on the firebowl **7** using 8mm bolts **I** and M4 nuts **D**.

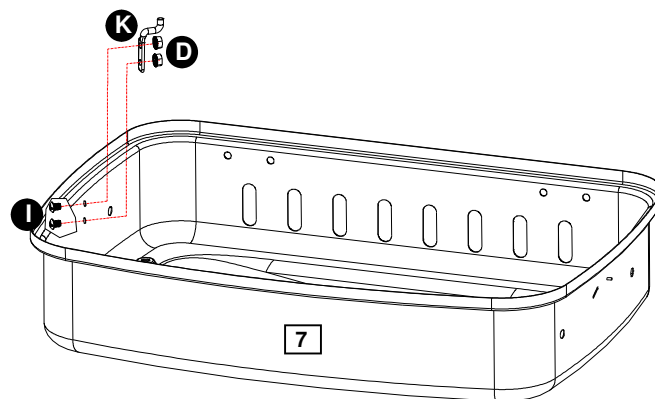

Assembly Instructions

Step 7

Set the firebowl **7** on the left upper support **15** and right upper support **16** using 20mm bolts **A**.

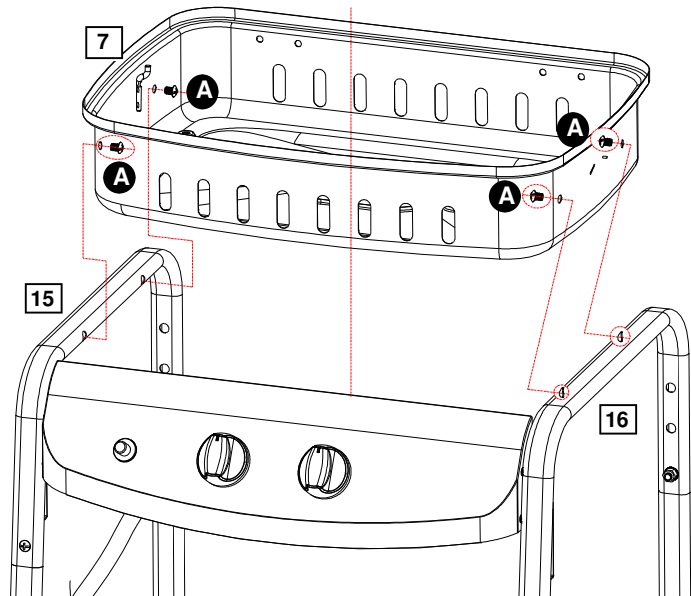

Step 8

a: Put the burner **6** through the hole of the firebowl **7**.

a:

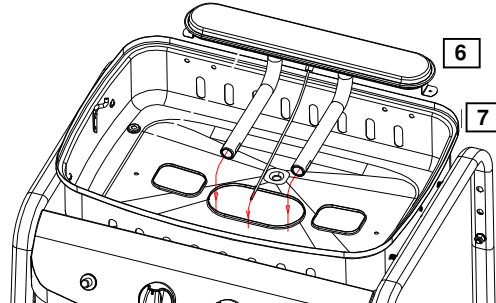

b: Align all valves on the control panel assembly **17** against each venturi of the burner **6**.

b:

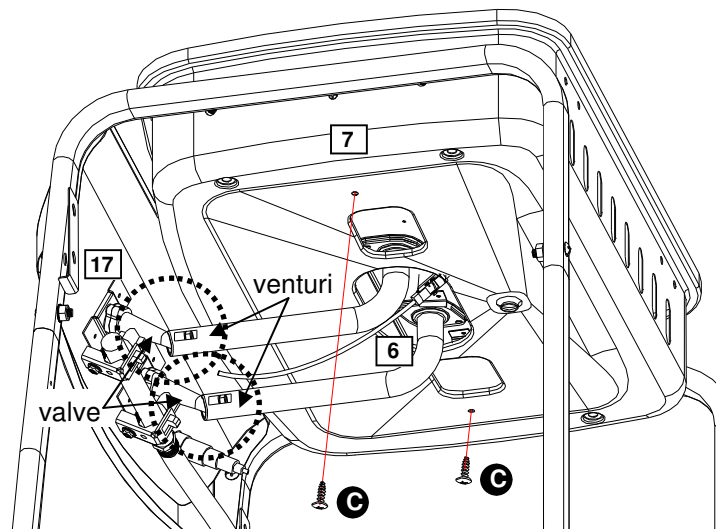

Important:

Make sure the valve tip goes into the venturi tube completely with good alignment.

Fix the burner **6** on the firebowl **7** using 10mm screws **C**.

Assembly Instructions

Step 9

Fix the hinge **5** on the fire-bowl **7** using 8mm bolts **G** and M5 nuts **M**.

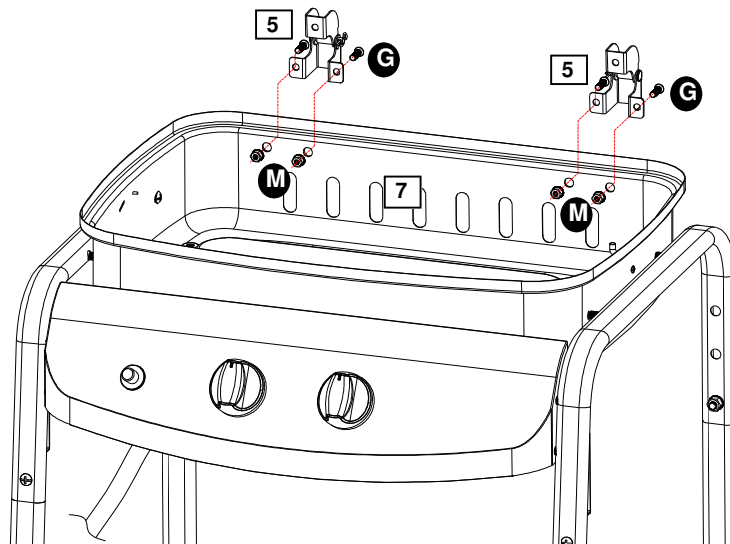

Step 10

Put the washer **E** between the lid handle **2** and the lid **1**.

Align the holes and fix the lid handle **2** on the lid **1** using 8mm bolts **G**.

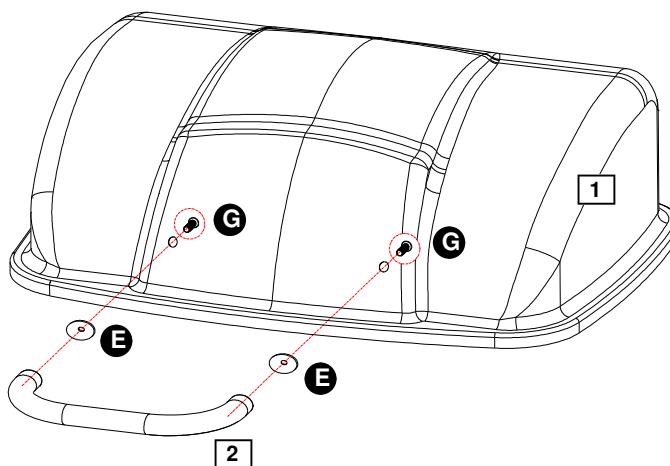

Assembly Instructions

Step 11

Fix the lid **1** and firebowl **7** by the hinge **5** using 8mm bolts **G** and M5 nuts **M**.

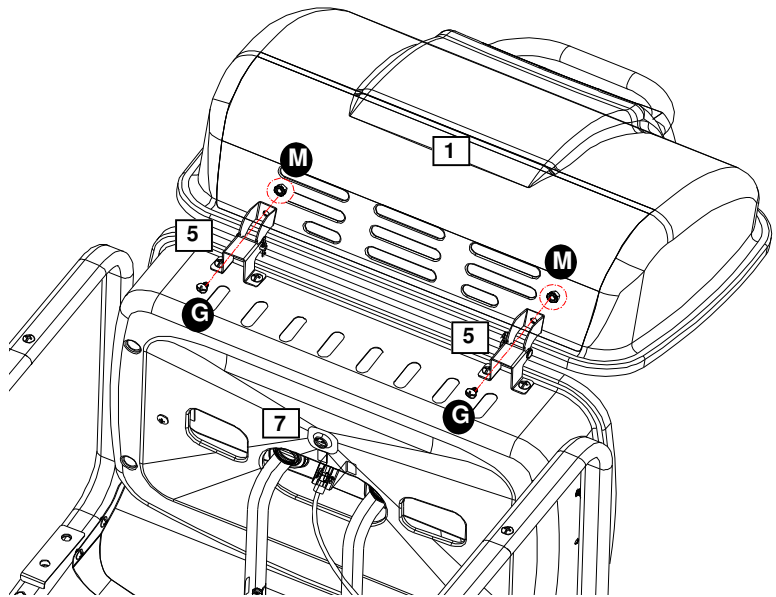

Step 12

Assemble the side table front support **21** and the side table rear support **22** to the side table **20**.

Secure the supports with 10mm screws **C**.

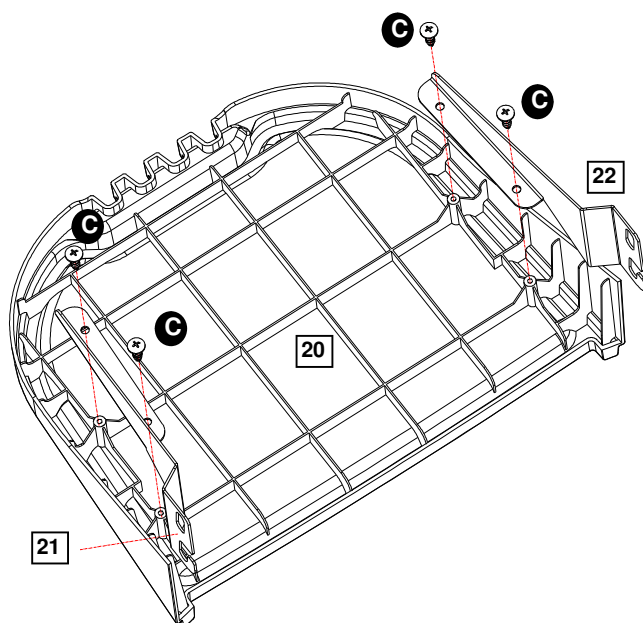

Assembly Instructions

Step 13

Install the side table assembly made on step 12 to the right upper support by **16** 15mm shoulder bolts **H**.

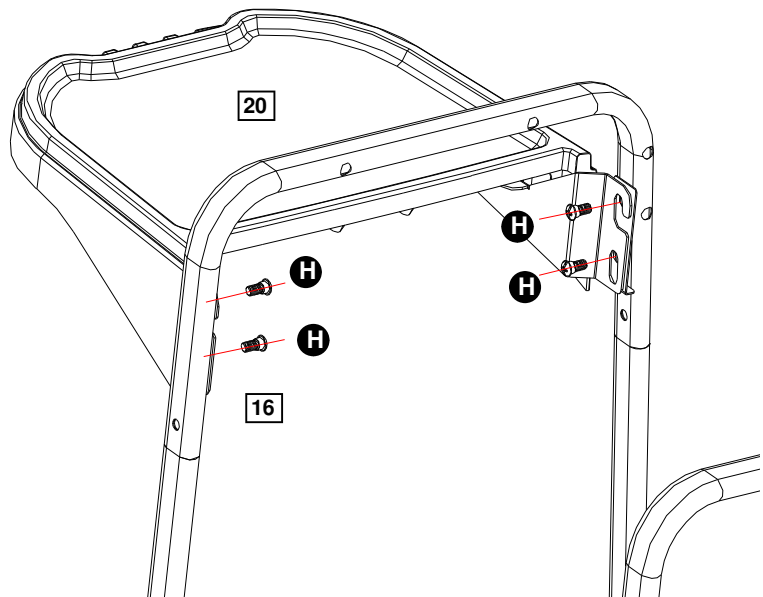

Step 14

Install the side burner assembly **23** to the left upper support **15** using 12mm bolts **B**.

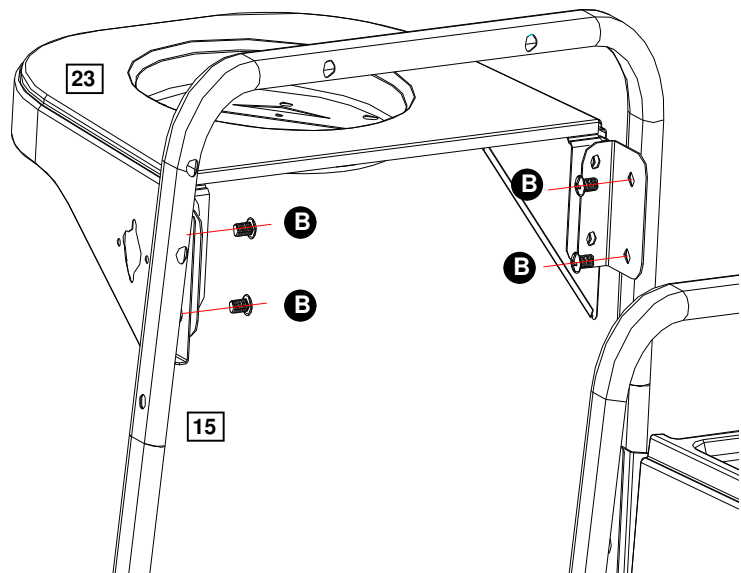

Assembly Instructions

Step 15

a: Loosen the pre-assembled screws on the side burner valve of the control panel assembly **17**.

a:

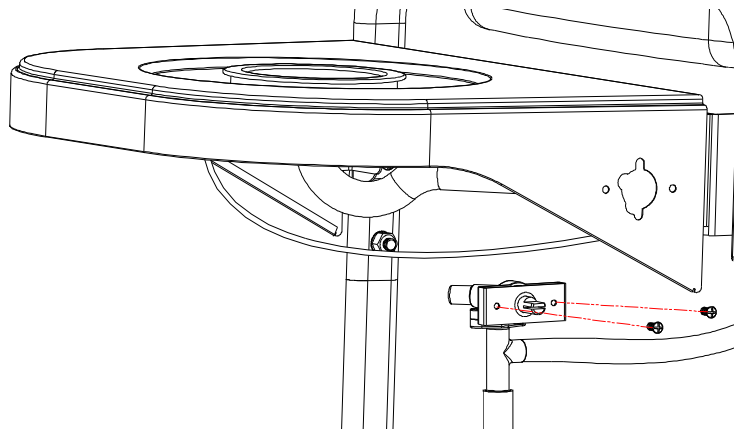

b: Fix the side burner valve on the side burner panel bracket of the side burner assembly **23** using the screws.

b:

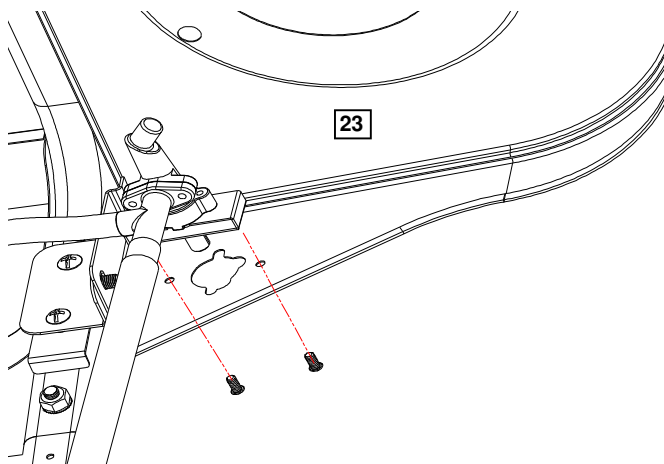

c: Put the side burner **26** and the side burner electrode **25** through the hole of side burner assembly **23**.

c:

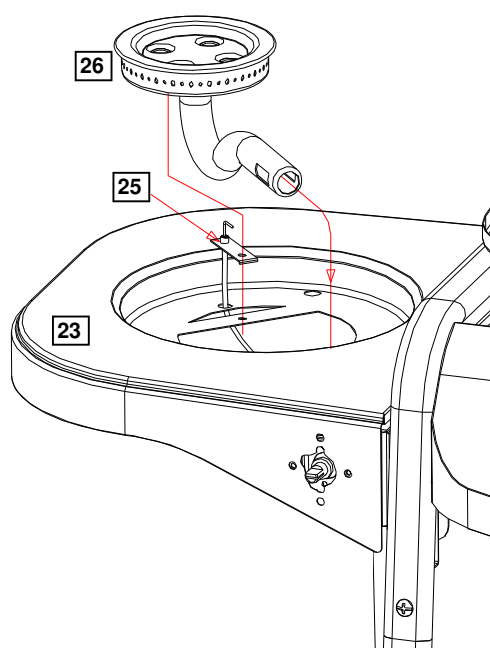

Assembly Instructions

Step 15

d: Align the venturi of the side burner **26** against the valve.



Important:

Make sure the valve tip goes into the venturi tube completely with good alignment.

Then tighten the side burner on the side burner assembly using 8mm bolt **1**.

Connect the electrode of the main burner **6** and the side burner electrode **25** to the electrode end of ignitor on the control panel assembly **17**.

d:

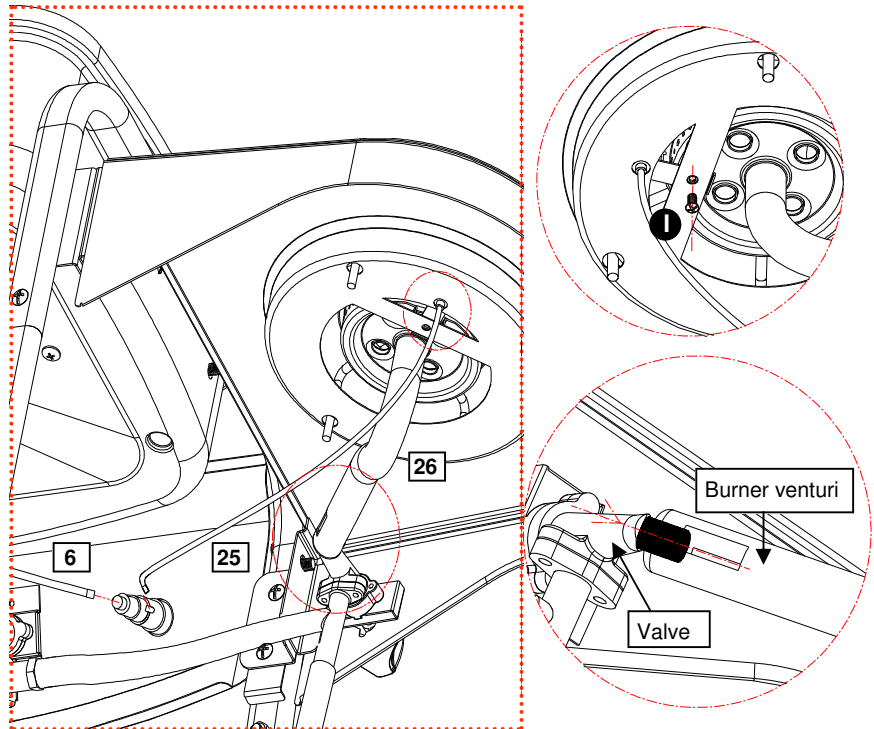

Electrode of Main Burner

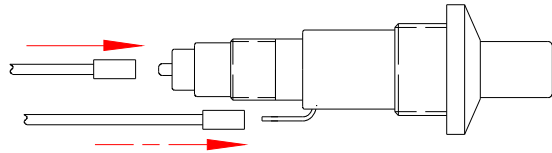

Electrode of Side Burner

e: Put the side burner grate **27** on the side burner assembly **23** and align with 3 holes.

e:

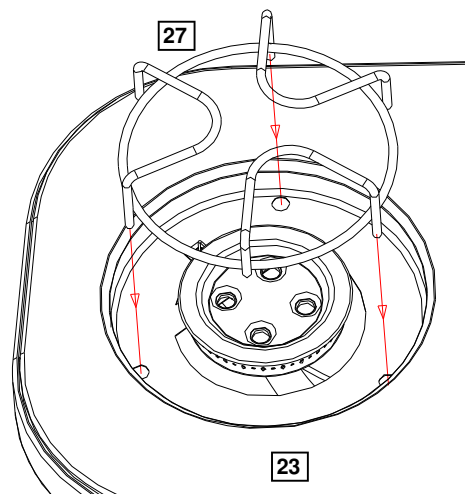

Assembly Instructions

Step 15

f: Insert the hook end of the venturi clip **[28]** into the air hole of the side burner venturi. Then clip another end on the side burner valve.

The venturi clip is used to stabilize the side burner so as to make sure the side burner valve tip goes into the burner venturi securely with the right position.

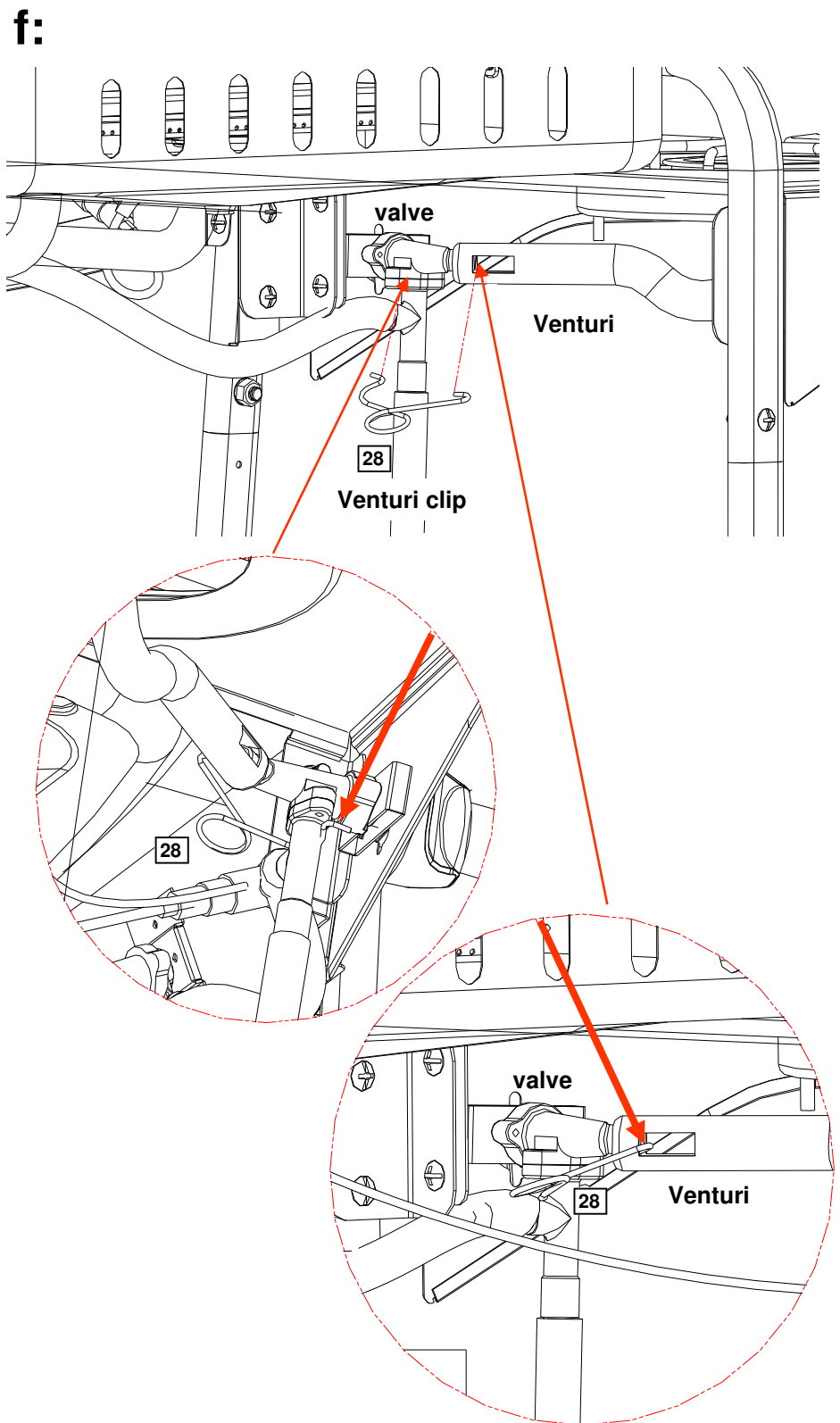

Assembly Instructions

Step 16

Put the grease cup hanger **8** through the hole of the firebowl **7**.

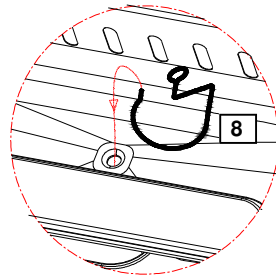
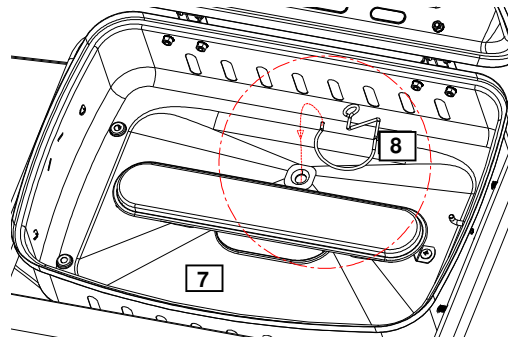

Top view

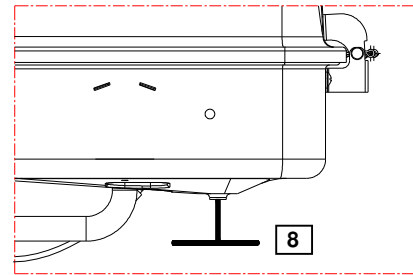

Side view

Step 17

Hang the grease cup **9** on the grease cup hanger **8**.

Attach the front canvas **18** to the left front leg **12** and right front leg **10**.

Secure the position with the velcro on canvas edge.

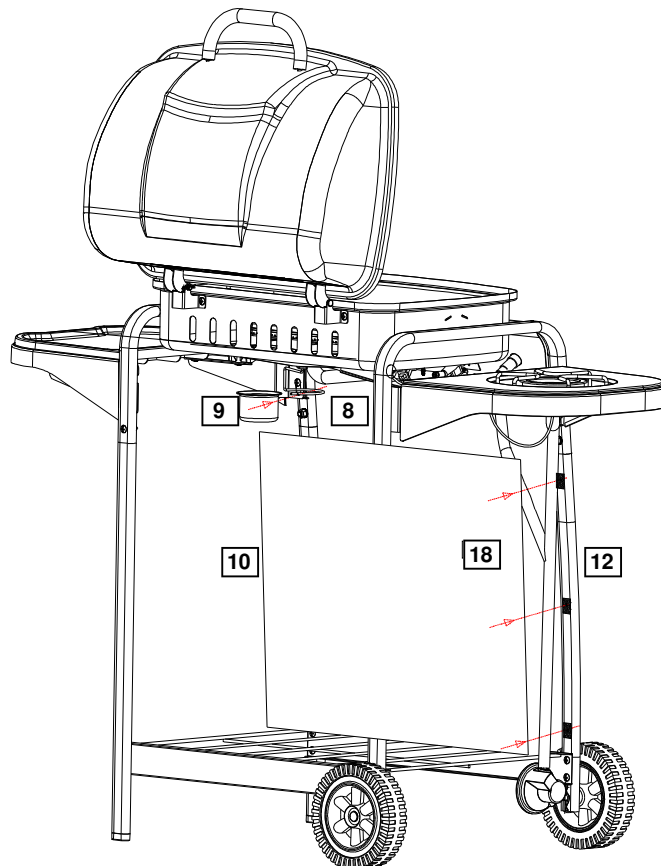

Assembly Instructions

Step 18

Put the side burner knob **24** on the side burner assembly **23**.

Put the heat tent **4** and cooking grill **3** on the fire-bowl **7**.

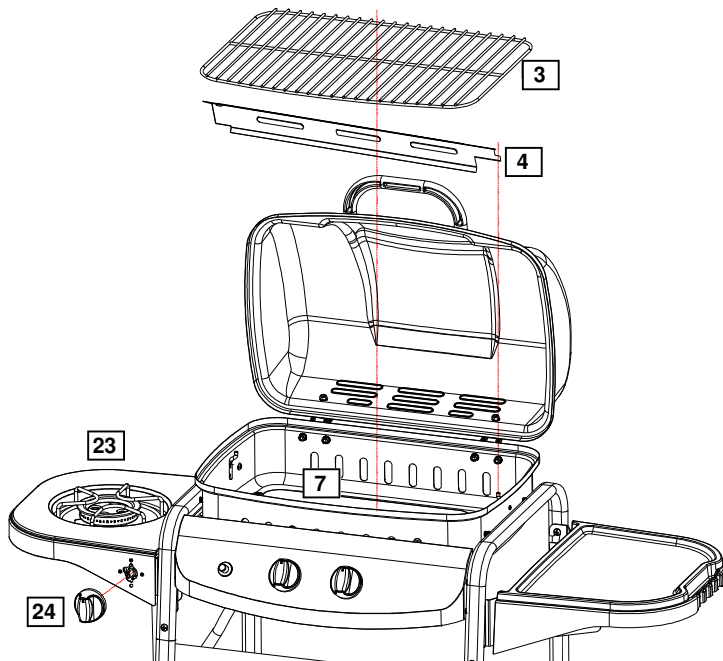

Step 19

Assembly is complete.

ALL JOINTS AND CONNECTIONS MUST NOW BE LEAK TESTED BEFORE USING THE BARBECUE.

Leak test annually, and whenever the gas bottle is removed or replaced.

Always place the gas bottle at the side of the appliance. The gas bottle should be sited as far away from the appliance as possible without straining the hose. The hose length should not exceed 1.5 metres.

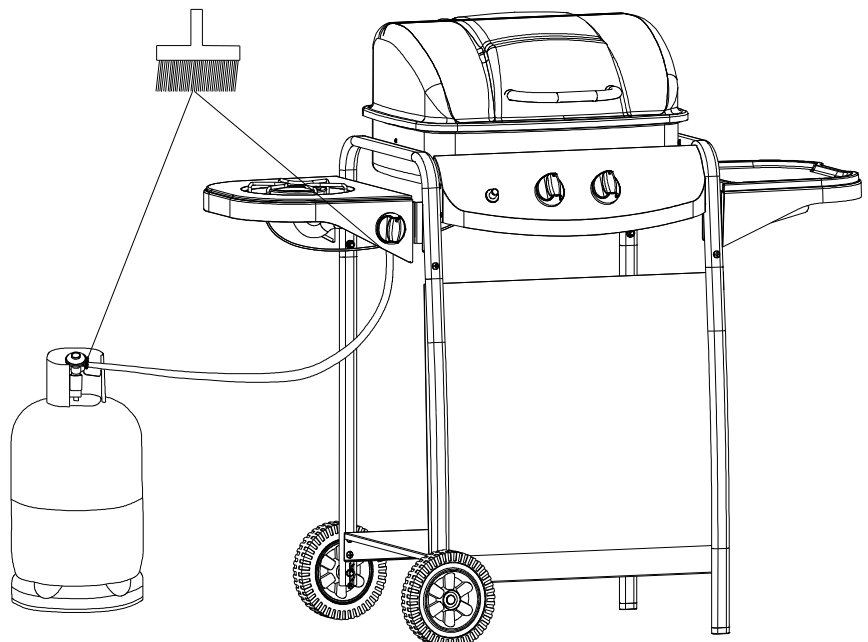

If you need help or have damaged or missing parts, call the **Customer Helpline: 03456 400800(Argos)/ 03450 778888 (Homebase).**

Technical Specification

Model Number	KS0993	
Gas Category	l3+(28-30/37)	
Type of Gas	Propane	Butane
Gas Pressure	37 mbar	28 - 30 mbar
Pin Number	359/BU/1015	
Injector Size (Main Burner)	0.75mm	
Injector Size (Side Burner)	0.74mm	
Total Heat Input	7.0 kW	
2 Burner Heat Input	4.7 kW	
Side Burner Heat Input	2.3 kW	
Gas Consumption	500 g/h	
Country of Destination	GB and IE	

Do not use this barbecue outside England and Ireland.

This barbecue grill is imported by:

Argos Limited/ Homebase Limited
 489-499 Avebury Boulevard
 Saxon Gate West
 Milton Keynes
 MK9 2NW

Troubleshooting

<i>Problem</i>	<i>Possible Cause</i>	<i>Solution</i>
<i>Burner will not light using the ignition system</i>	LP gas cylinder is empty	Replace with full cylinder
	Faulty regulator	Have regulator checked or replace
	Obstructions in burner	Clean burner
	Obstructions in gas jets or gas hose	Clean jets and gas hose
	Electrode wire is loose or disconnected on electrode or ignition unit.	Reconnect wire
	Electrode or wire is damaged	Change electrode and wire
Faulty push button ignitor	Change ignitor	
<i>Burner will not light with a match</i>	LP gas cylinder is empty	Replace with full cylinder
	Faulty regulator	Have regulator checked or replace
	Obstructions in burner	Clean burner
	Obstructions in gas jets or gas hose	Clean jets and gas hose
<i>Low flame or flashback (fire in burner tube— a hissing or roaring noise may be heard)</i>	LP gas cylinder too small	Use larger cylinder.
	Obstructions in burner	Clean burner
	Obstructions in gas jets or gas hose	Clean jets and gas hose
	Windy conditions.	Use BBQ in a more sheltered position
<i>Gas valve knob difficult to turn</i>	Gas valve jammed	Replace gas valve