

# Ohio - 2+2 Sideboard

Assembly Instructions - Please keep for future reference

322/3468

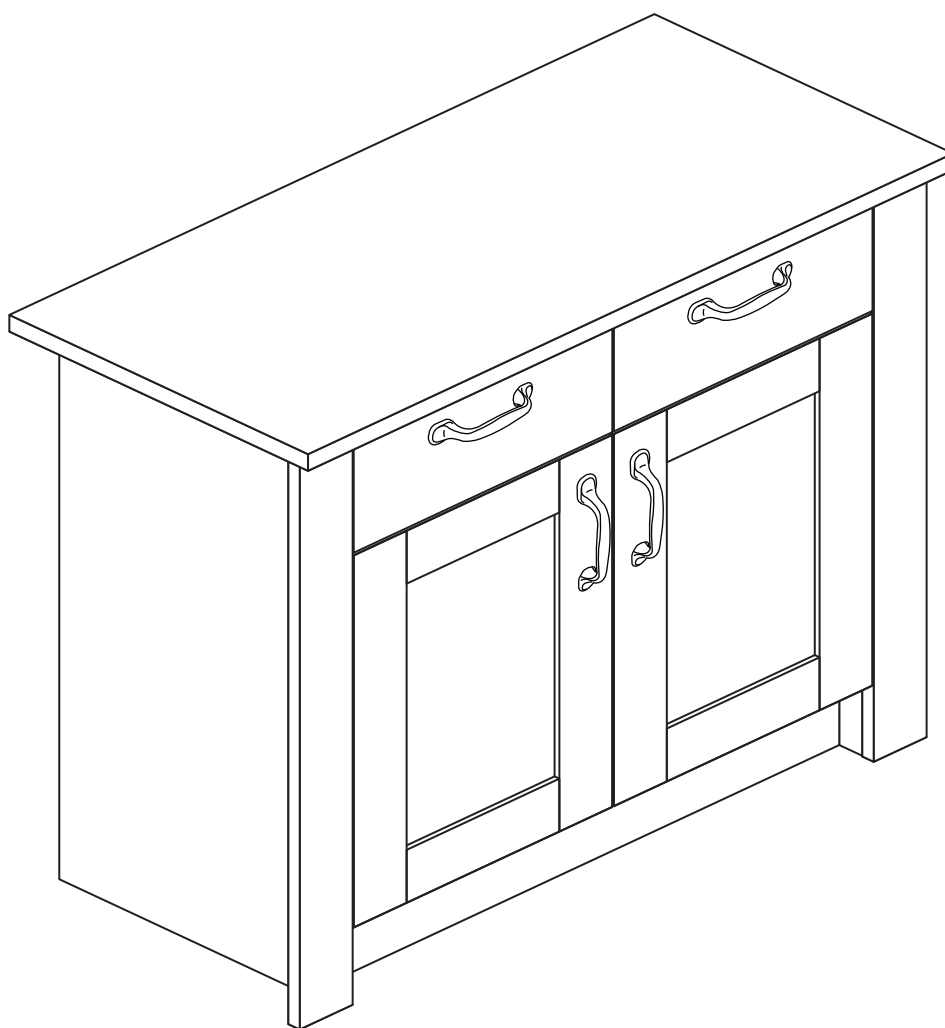

## Dimensions

Width - 85.5cm

Depth - 39.5cm

Height - 78cm



**MADE IN  
BRITAIN**

**Important** - Please read these instructions fully before starting assembly

If you need help or have damaged or missing parts, call the **Customer Helpline: 08456 400800**



# Safety and Care Advice

**Important - Please read these instructions fully before starting assembly**

- **Warning:** This unit weighs approximately 25kgs. Please lift with care.
- Check you have all the components and tools listed on pages 2 and 3.
- Remove all fittings from the plastic bags and separate them into their groups.
- Keep children and animals away from the work area, small parts could choke if swallowed.
- Parts of the assembly will be easier with 2 people.

- Make sure you have enough space to layout the parts before starting.
- Do not stand or put weight on the product, this could cause damage.
- Assemble the item as close to its final position (in the same room) as possible.
- Assemble on a soft level surface to avoid damaging the unit or your floor (use opened out unit carton).



• We do not recommend the use of power drill/drivers **for inserting screws**, as this could damage the unit. Only use hand screwdrivers.

• **Safety note:** It is recommended that this unit is secured to a wall using the bracket supplied.

• Dispose of all packaging carefully and responsibly.

## Care and maintenance

- Only clean using a damp cloth and mild detergent, do not use bleach or abrasive cleaners.
- From time to time check that there are no loose screws on this unit.
- This product should not be discarded with household waste. Take to your local authority waste disposal centre.

## Tools required

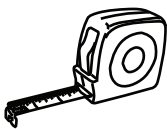

Rule



Cross-head screwdriver



Scissors



Hammer



Eye protection  
(when using a hammer or drill)



Electric drill  
(do not use for fitting screws)

**Note:** If required the next page can be cut out and used as reference throughout the assembly. Keep this page with these instructions for future reference.

# Components - Panels

If you have damaged or missing components, call the **Customer Helpline: 08456 400800** quoting the reference numbers below

Please check you have all the panels listed below

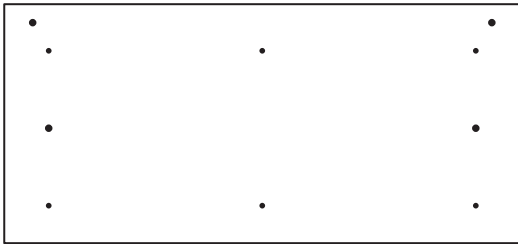

**1** Top (D1800A)  
(853 x 395mm)

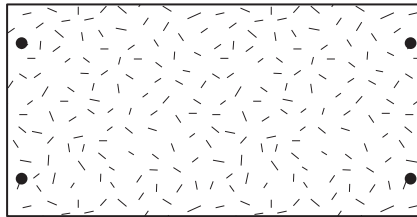

**2** Base (D1803A)  
(691 x 350mm)

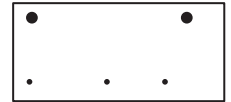

**3** Divider (D1804B)  
(162 x 349mm)

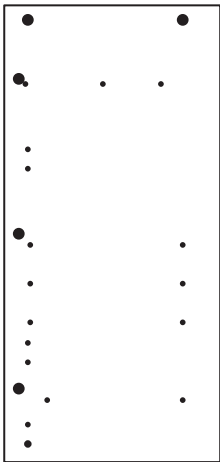

**4** Left Side (D1812B)  
(755 x 357mm)

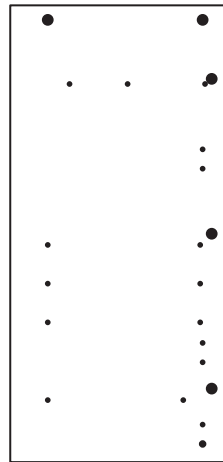

**5** Right Side (D1813B)  
(755 x 357mm)



**6** Plinth (D1805A)  
(691 x 95mm)



**7** Fascia (D1806A)  
(755 x 70mm) x 2

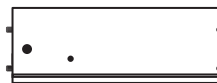

**8** Left Drawer Side (W350-124LH)  
(350 x 124mm) x 2

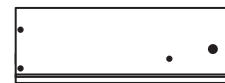

**9** Right Drawer Side (W350-124RH)  
(350 x 124mm) x 2



**10** Drawer Base (T297-347)  
(297 x 347mm) x 2



**11** Drawer Back (W286-124)  
(286 x 124mm) x 2

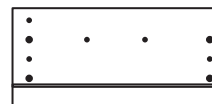

**12** Left Drawer Front (D1809A)  
(342 x 162mm)

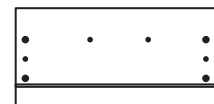

**13** Right Drawer Front (D1810A)  
(342 x 162mm)



**14** Shelf (D1807A)  
(689 x 347mm)

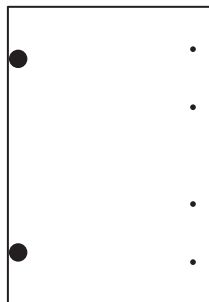

**15** Door (D1808A)  
(492 x 342mm) x 2

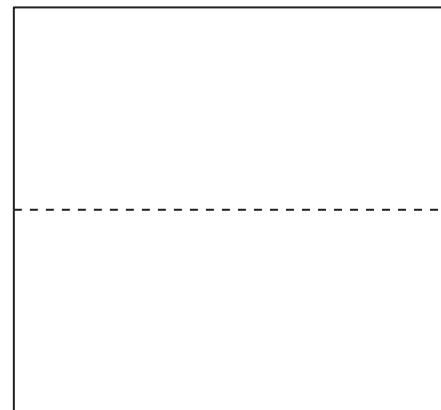

**16** Back (X920)  
(709 x 669mm)











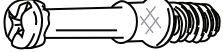

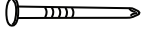



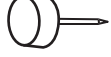

# Components - Fittings

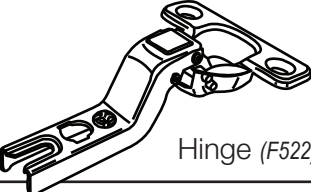
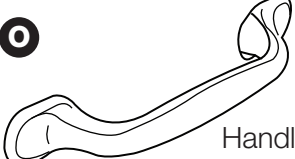
If you have damaged or missing components, call the **Customer Helpline: 08456 400800** quoting the reference numbers below

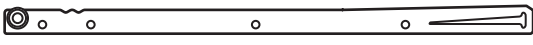
Please check you have all the fittings listed below

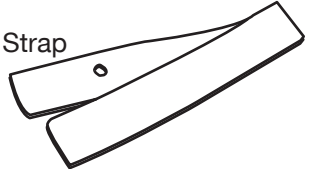
**Note:** The quantities below are the correct amount to complete the assembly. In some cases more fittings may be supplied than are required.

<p><b>A</b> </p> <p>Wooden dowel (F22) x 6</p>	<p><b>B</b> </p> <p>Metal dowel (F901) x 22</p>	<p><b>C</b> </p> <p>Large locking nut (F900) x 18</p>
<p><b>D</b> </p> <p>Small locking nut (F3) x 4</p>	<p><b>E</b> </p> <p>Nail (F51) x 19</p>	<p><b>F</b> </p> <p>Shelf support (F121) x 4</p>
<p><b>G</b> </p> <p>Knock-in Peg (F171) x 8</p>	<p><b>H</b> </p> <p>19mm Screw (F461) x 8</p>	<p><b>I</b> </p> <p>Wedgefix (F639) x 4</p>
<p><b>J</b> </p> <p>9mm Screw (F73) x 12</p>	<p><b>K</b> </p> <p>13mm Screw (F63) x 20</p>	<p><b>L</b> </p> <p>Plastic Nail (F91) x 4</p>
<p><b>M</b> </p> <p>Hinge plate (F523) x 4</p>	<p><b>N</b> </p> <p>Hinge (F522) x 4</p>	<p><b>O</b> </p> <p>Handle (F287) x 4</p>
<p><b>Pa</b>  L Runner (F159) x 2</p> <p><b>Pb</b>  R Runner (F160) x 2</p> <p><b>Pc</b>  L Runner (F161) x 2</p> <p><b>Pd</b>  R Runner (F162) x 2</p>	<p><b>P</b> </p> <p>Strap</p> <p> Screw  Washer x 2</p> <p>Overbalance protector kit (F269) x</p>	

Ruler - Use this ruler to help correctly identify the screws

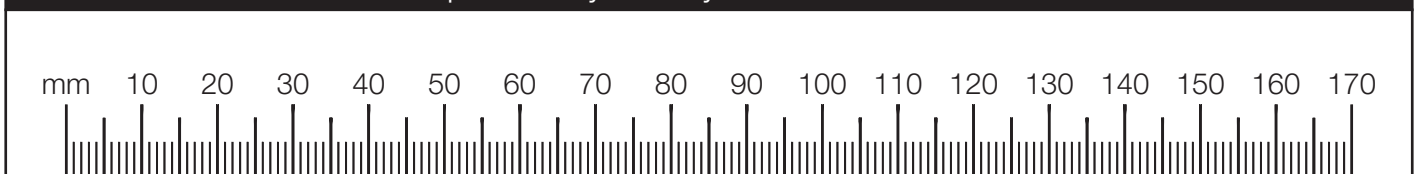

# Assembly Instructions

If you have damaged or missing components, call the  
**Customer Helpline: 08456 400800** quoting the reference  
numbers below

## Step 1

### Prepare the drawer fronts

Screw 2 metal dowels **B** into the holes shown on the back of the left drawer front **12** and the right drawer front **13**.

**Note:** Tighten metal dowels up fully against the panels.

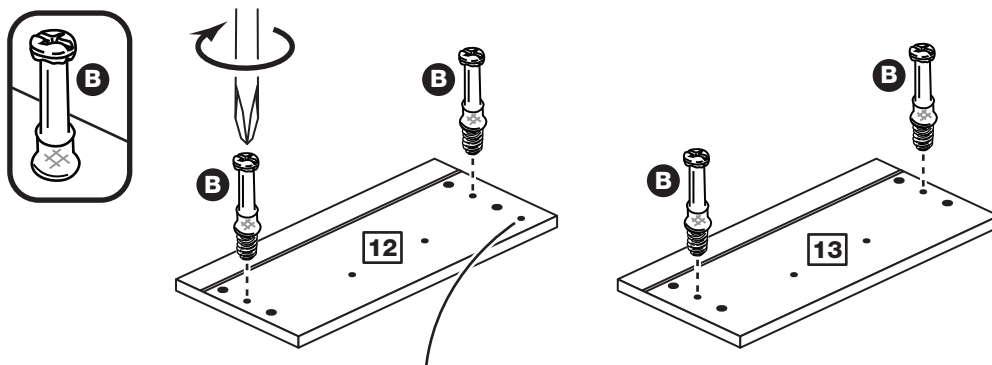

**Note:** The left drawer front **12** has a small identification hole.

## Step 2

### Prepare the drawer sides

Insert a small locking nut **D** into the hole shown on the left drawer side **8** and right drawer side **9**.

**Note:** Arrow on locking nut **must** point towards hole in edge of panel.

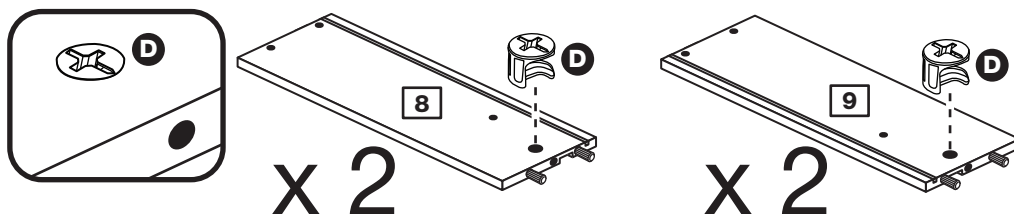

## Step 3

### Attach the drawer sides to the drawer front

Push the left drawer side **8** and right drawer side **9** onto the back of the drawer fronts **12** and **13**.

Turn the small locking nuts **D** on the left drawer side **8** and right drawer side **9**.

**Note:** Turn the locking nuts **D** clockwise to secure panels - more than 1/2 a turn.

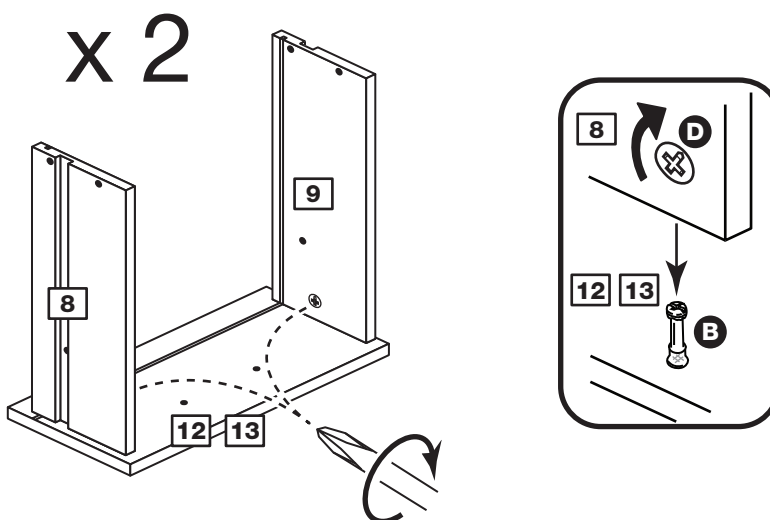

# Assembly Instructions

## Step 4

### Fit the drawer base

Slide the drawer base **10** down the grooves in the drawer sides **8** and **9** and down into the groove in the drawer front **12** and **13**.

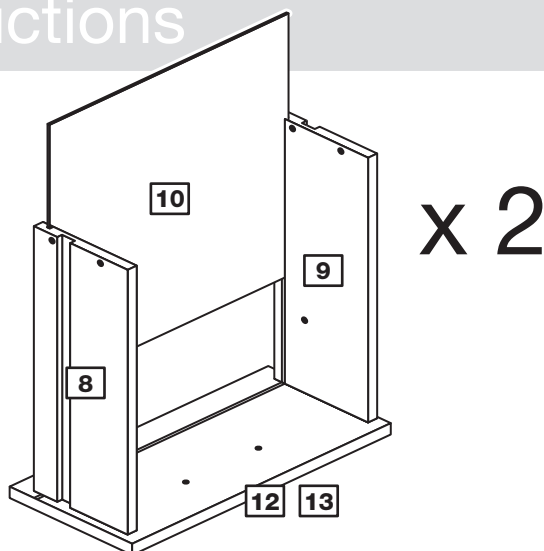

## Step 5

### Fit the drawer back

Fit the drawer back **11** between the drawer sides **8** and **9**.

Make sure that the drawer base **10** fits into the groove in the drawer back **11**.

Hold the drawer back **11** in position and tap the knock-in pegs **G** through the holes in the drawer sides **8** and **9**.

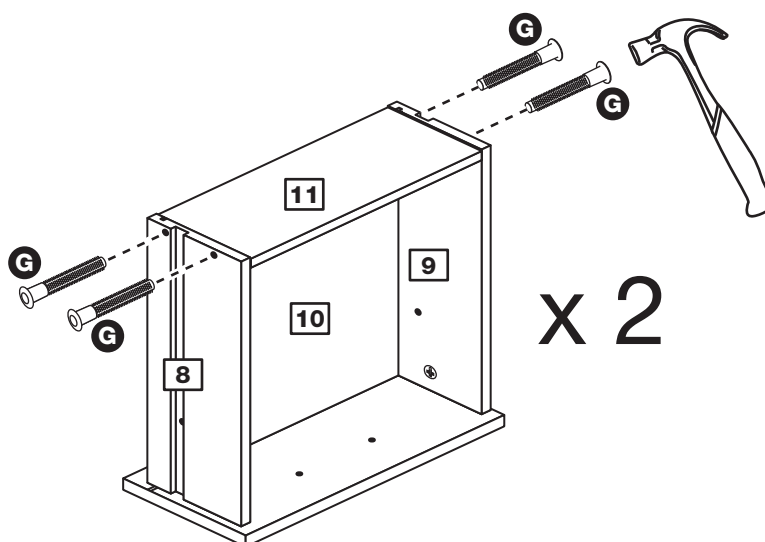

## Step 6

### Attach the handles

Attach a handle **O** to each drawer front **12** and **13** using 2 screws **H**.

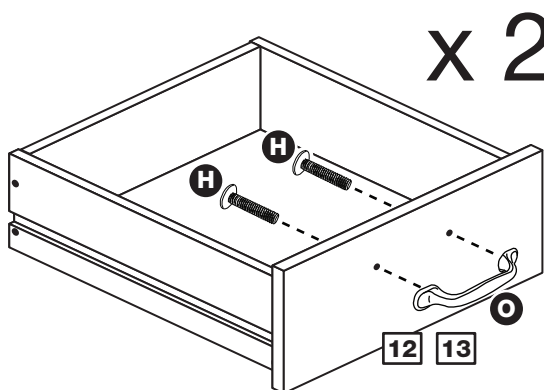

## Step 7

### Fit the wedgifixes

Turn the drawer assembly over and slide 2 wedgifixes **I** into the front and back grooves, as shown, and tighten up the screws.

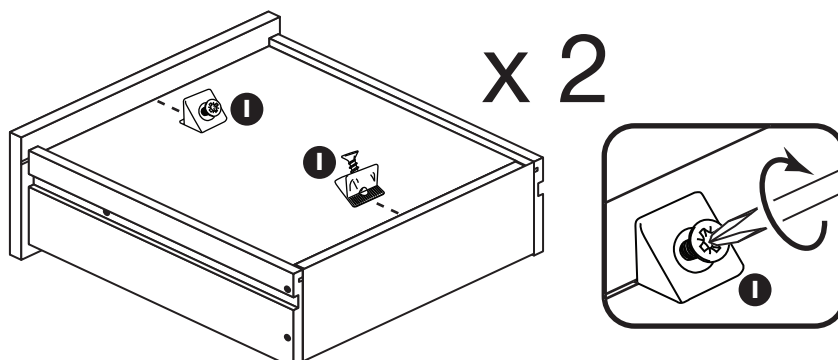

# Assembly Instructions

## Step 8

### Fit runners to the drawers

Turn the drawer assemblies over.

Fit the runner **Pc** to the bottom edge of the left drawer side **8**, as shown, making sure that it is pushed up against the back of the drawer front **12** and **13**. Use a bradawl to mark the fixing positions, then secure with 2 screws **K**.

Fit the runner **Pd** to the bottom edge of the right drawer side **9** using the same method.

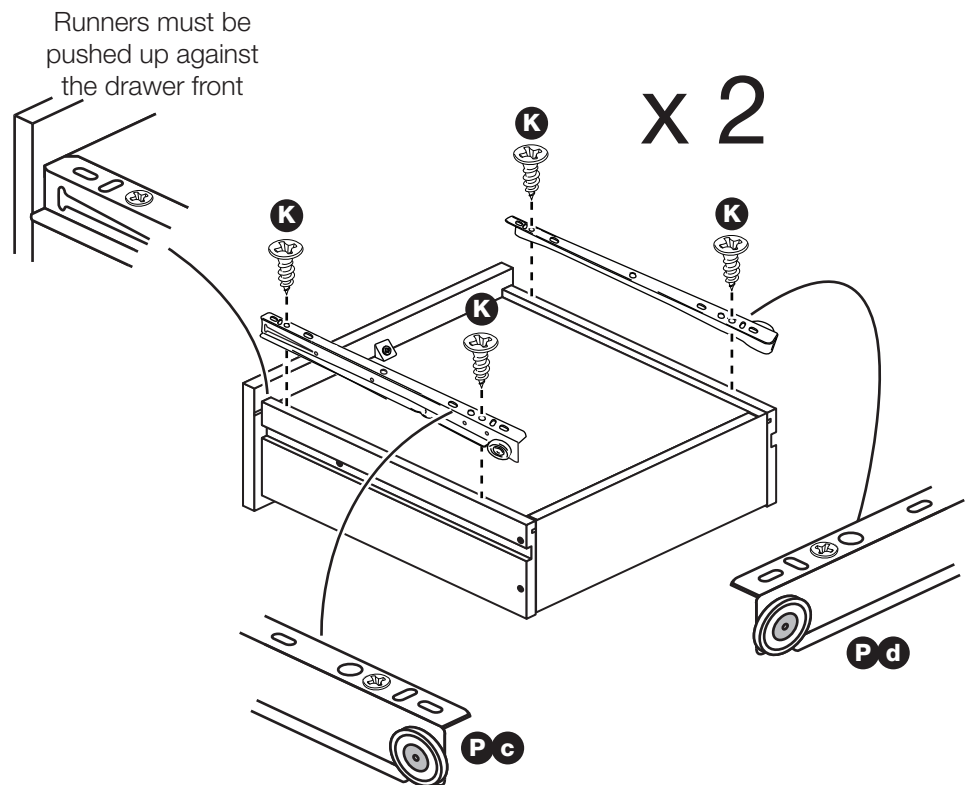

## Step 9

### Prepare the 2 fascias

Check that the holes are in the same place as the diagrams, as one will be the left fascia and one will be the right fascia.

Screw 3 metal dowels **B** into each of the 2 fascias **7**.

Tap a wooden dowel **A** into each of the 2 fascias **7**.

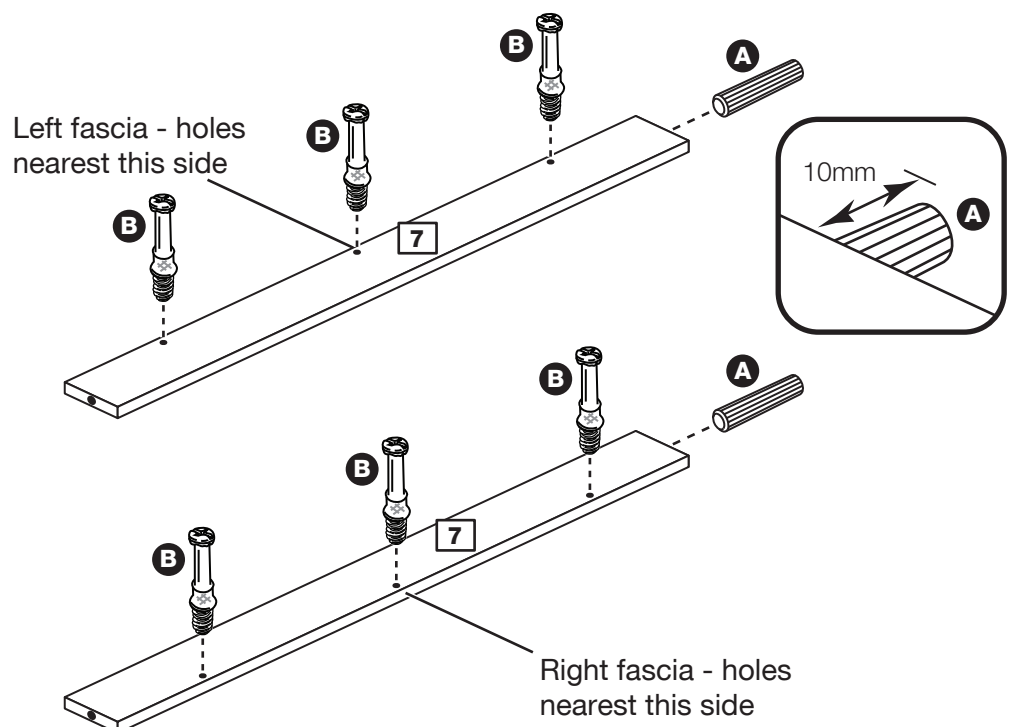

# Assembly Instructions

## Step 10

### Prepare the left side

Insert 3 large locking nuts **C** into the left side **4**.

**Note:** The arrow on the locking nuts **must** point towards the holes in the edge of the panel.

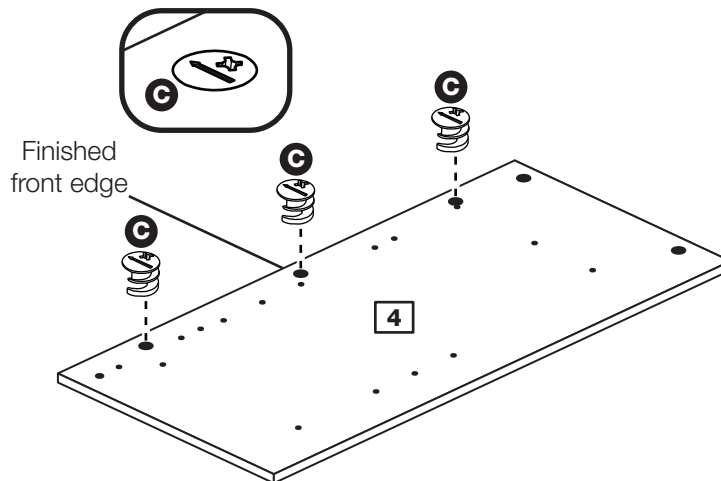

## Step 11

### Join the left side to the left fascia panel

**a:** Push the left side **4** down onto the left fascia panel **7**.

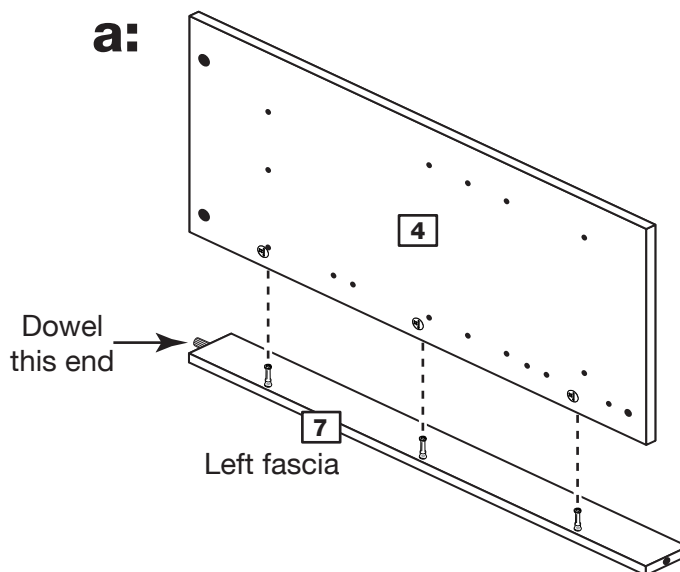
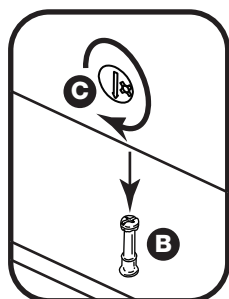

**b:** Use a screwdriver to tighten the 3 large locking nuts **C** fitted to the left side **4**.

**Note:** Turn the large locking nuts **C** as far as they will go - more than 1/2 a turn.

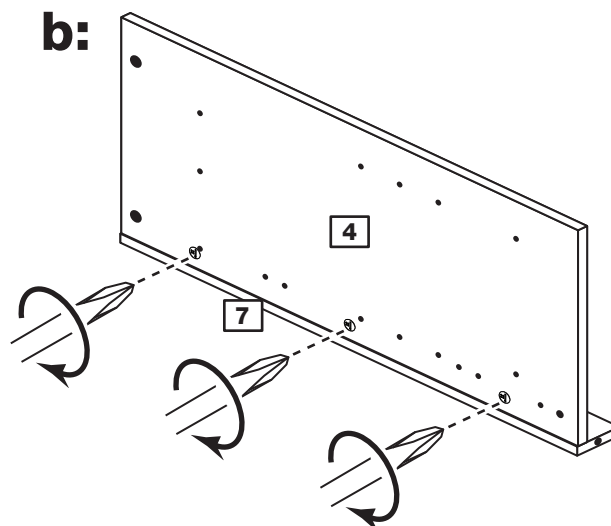



# Assembly Instructions

## Step 12

### Prepare the right side

Insert 3 large locking nuts **C** into the right side **5**.

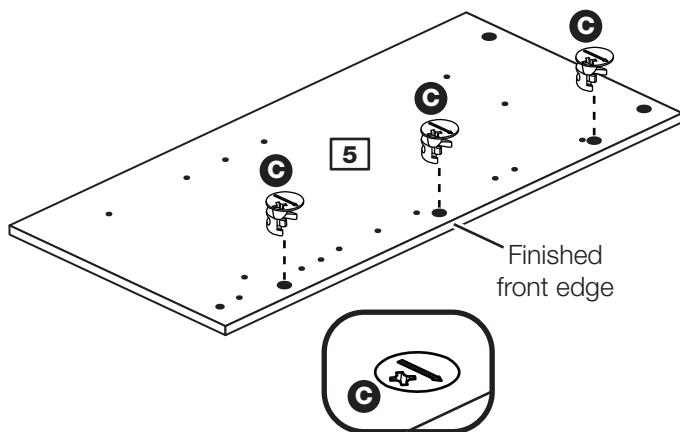

## Step 13

### Join the right side to the right fascia panel

**a:** Push the right side **5** down onto the right fascia panel **7**.

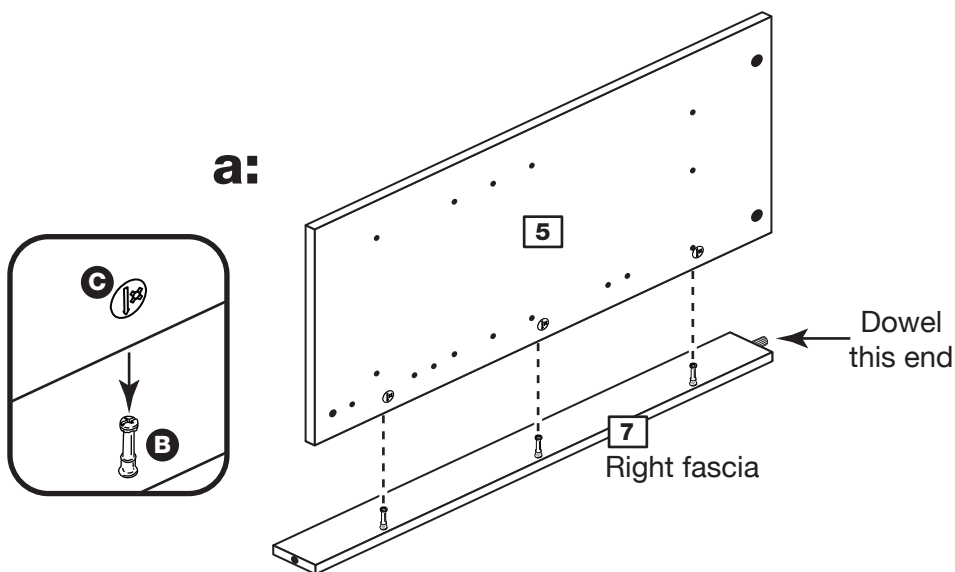

**b:** Use a screwdriver to tighten the 3 large locking nuts **C** fitted to the right side **5**.

**Note:** Turn the large locking nuts **C** as far as they will go - more than 1/2 a turn.

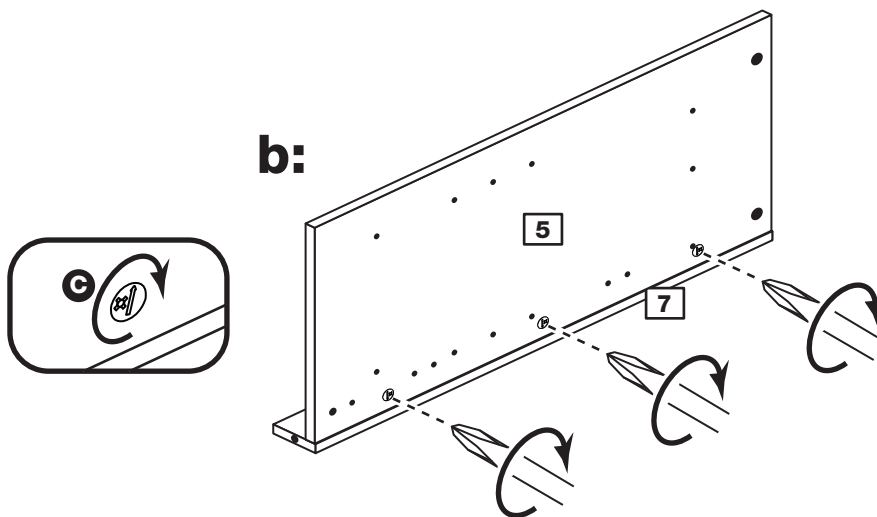

# Assembly Instructions

## Step 14

### Finish preparing the left side

**a:** Fit a runner **Pa** to the left side **4**.

The 1st screw **J** uses the 1st hole in from the front of the runner.

The 2nd and 3rd screws **J** use the holes that line up with the other panel holes.

Screw 3 metal dowels **B** into the left side **4**.

**b:** Fit a screw **K** into the 1st hole in at the top of the runner **Pa**.

Insert 2 large locking nuts **C** into the left side **4**.

Fit 2 hinge plates **M** onto the left side **4**, making sure that the slot is facing towards the finished front edge.

Tap a wooden dowel **A** into the left side **4**.

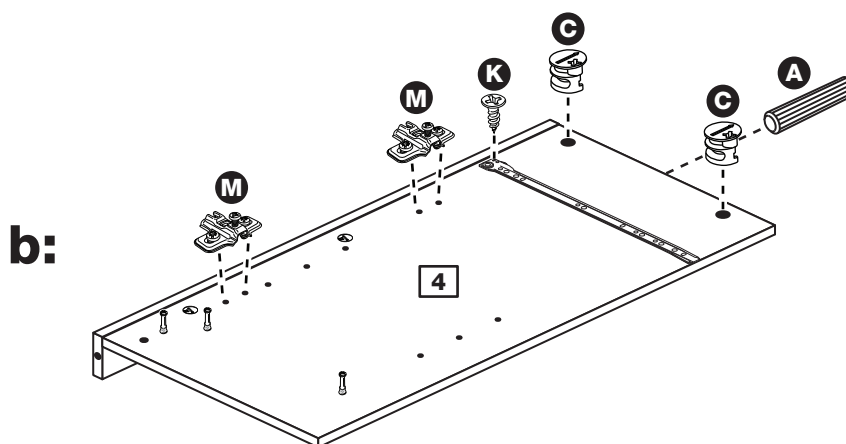
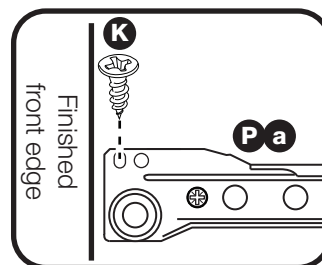
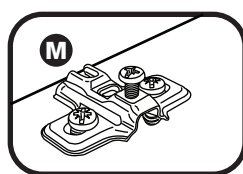
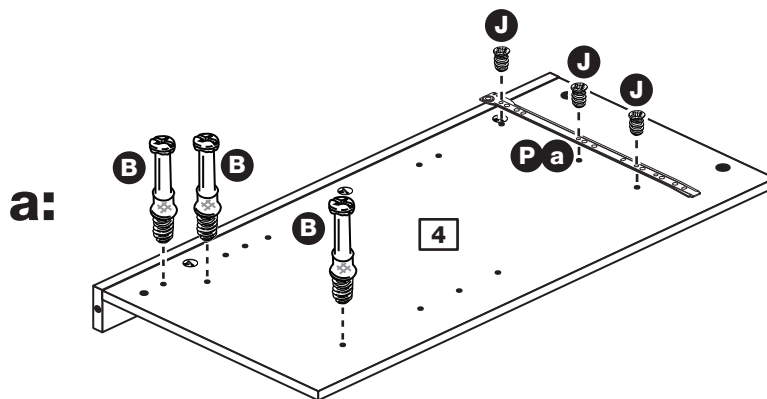
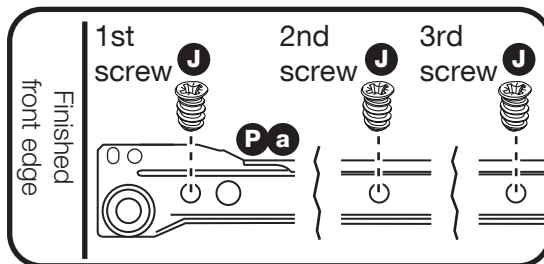

# Assembly Instructions

## Step 15

### Finish preparing the right side

**a:** Fit a runner **P b** to the right side **5**.

The 1st screw **J** uses the 1st hole in from the front of the runner.

The 2nd and 3rd screws **J** use the holes that line up with the other panel holes.

Screw 3 metal dowels **B** into the right side **5**.

**b:** Fit a screw **K** into the 1st hole in at the top of the runner **P b**.

Insert 2 large locking nuts **C** into the right side **5**.

Fit 2 hinge plates **M** onto the right side **5**, making sure that the slot is facing towards the finished front edge.

Tap a wooden dowel **A** into the right side **5**.

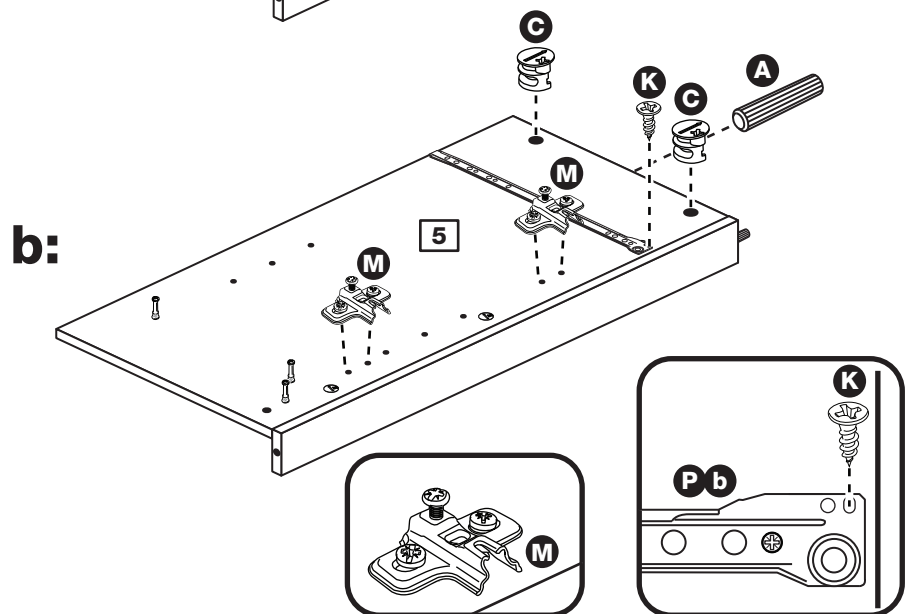
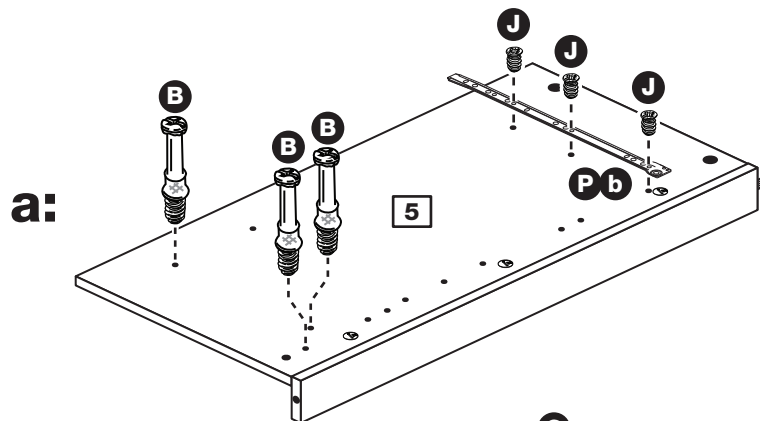
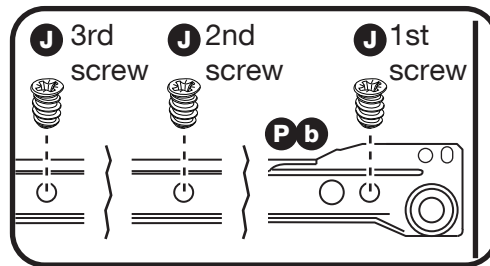

## Step 16

### Prepare the base

Insert 4 large locking nuts **C** into the base **2**.

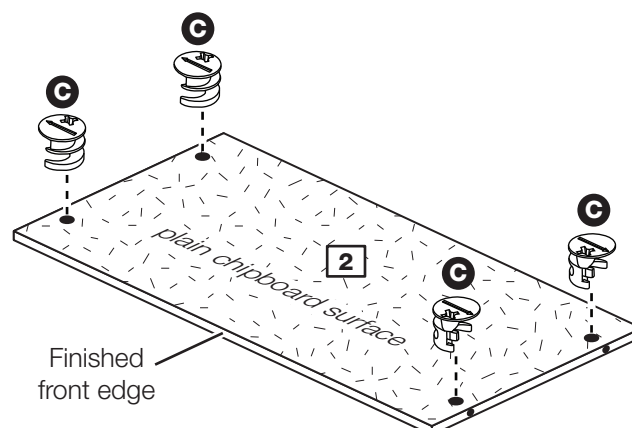

# Assembly Instructions

## Step 17

### Fit the base

Push the base **2** onto the right side **5**.

Use a screwdriver to tighten the 2 large locking nuts **C** fitted to the base **2**.

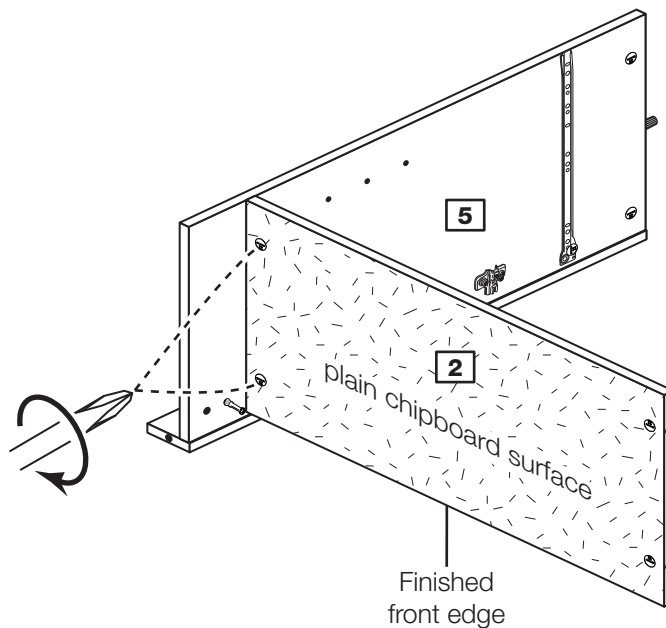

## Step 18

### Prepare the plinth

Tap 2 wooden dowels **A** into the plinth **6**.

Insert 2 large locking nuts **C** into the plinth **6**.

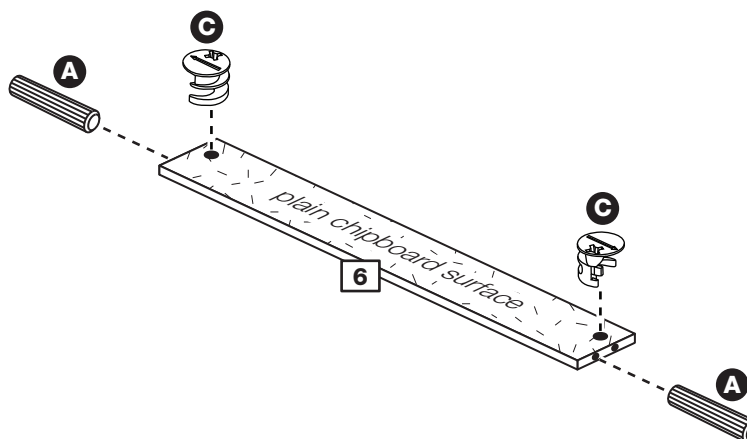

## Step 19

### Fit the plinth

Push the plinth **6** onto the right side **5**.

Use a screwdriver to tighten the large locking nut **C** fitted to the plinth **6**.

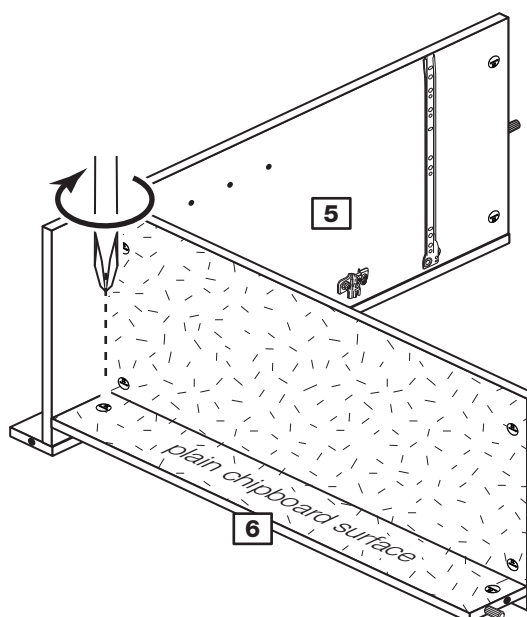

# Assembly Instructions

## Step 20

### Fit the left side

Push the left side **4** onto the assembly.

Use a screwdriver to tighten the 3 large locking nuts **C** fitted to the base **2** and plinth **6**.

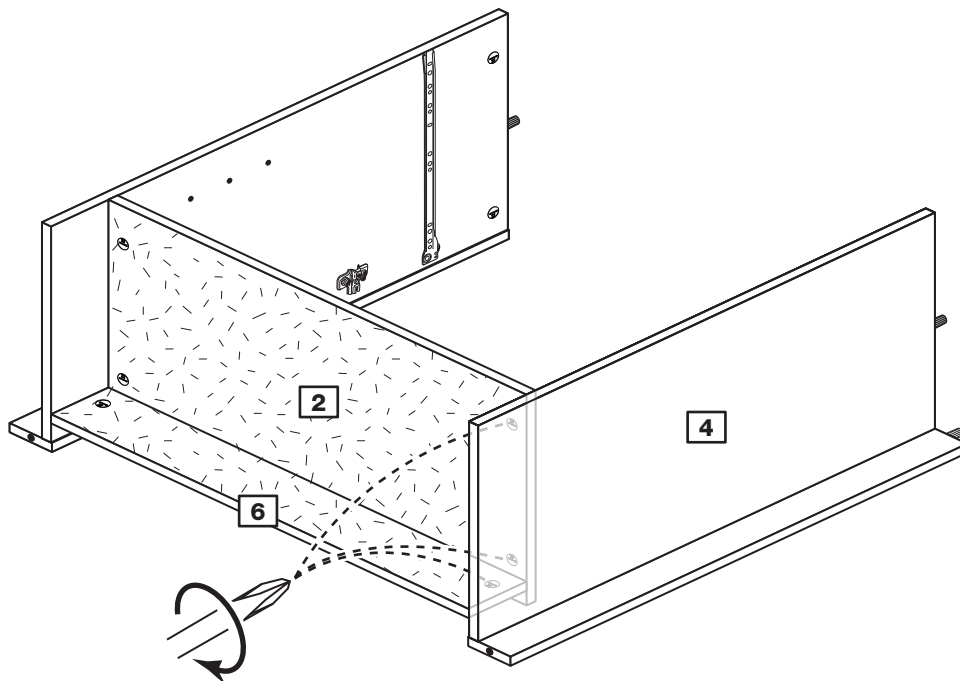

## Step 21

### Prepare the top

Screw 6 metal dowels **B** into the top **1**.

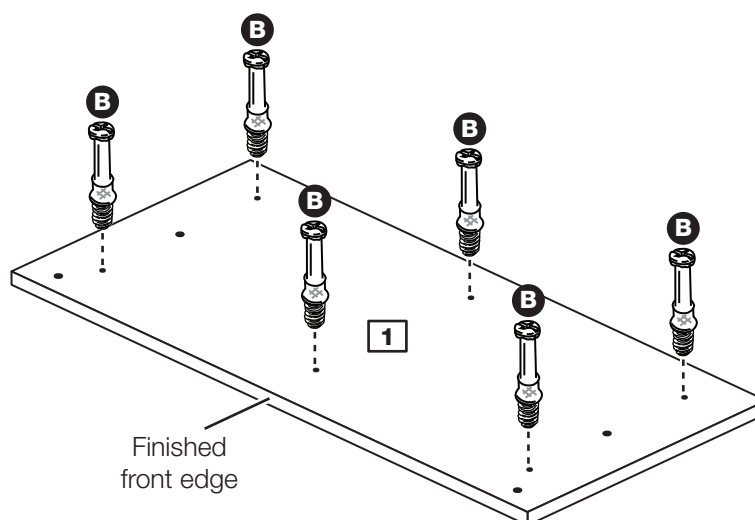

# Assembly Instructions

## Step 22

### Prepare the divider

**a:** Fit a runner **P a** to the divider **3**.

The 1st screw **J** uses the 1st hole in from the front of the runner.

The 2nd and 3rd screws **J** use the holes that line up with the other panel holes.

**b:** Fit a screw **K** into the 2nd hole in at the top of the runner **P a**.

Insert 2 large locking nuts **C** into the divider **3**.

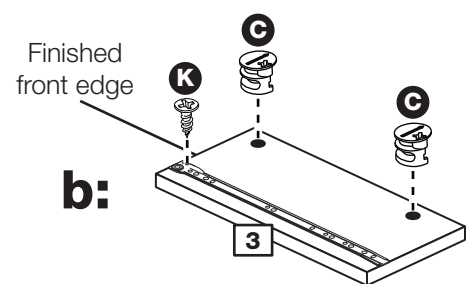
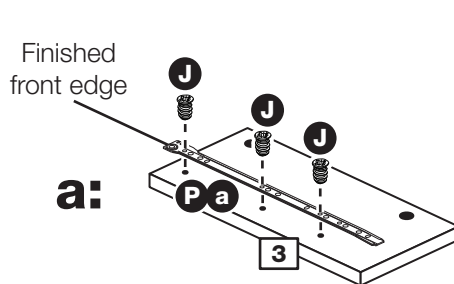
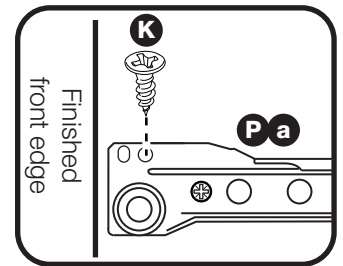
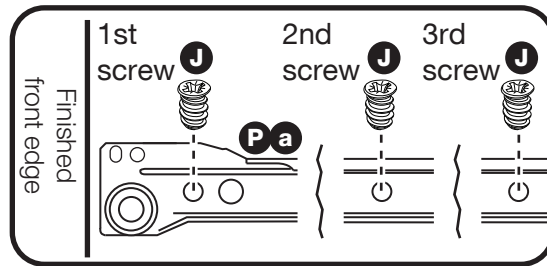

**Note:** Due to the manufacturing process, the 2 holes for the large locking nut can be on either surface of the divider.

### Turn the divider over



*Turn the divider over*

**c:** Fit a runner **P b** to the divider **3**.

The 1st screw **J** uses the 1st hole in from the front of the runner.

The 2nd and 3rd screws **J** use the holes that line up with the other panel holes.

**d:** Fit a screw **K** into the 2nd hole in at the top of the runner **P b**.

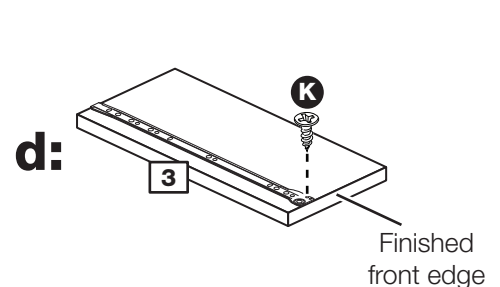
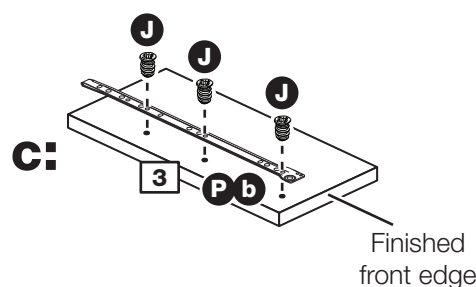
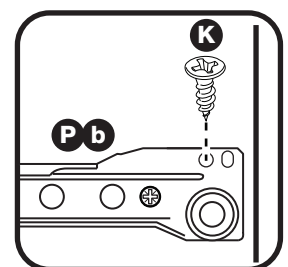
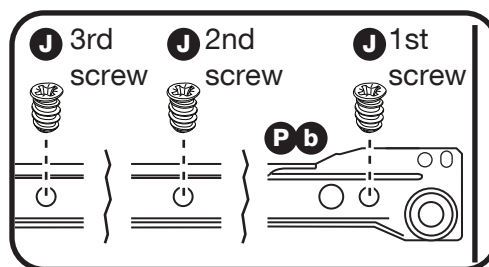

# Assembly Instructions

## Step 23

### Join the top and the divider

Push the divider **3** onto the top **1**.

Use a screwdriver to tighten the 2 large locking nuts **C** fitted to the divider **3**.

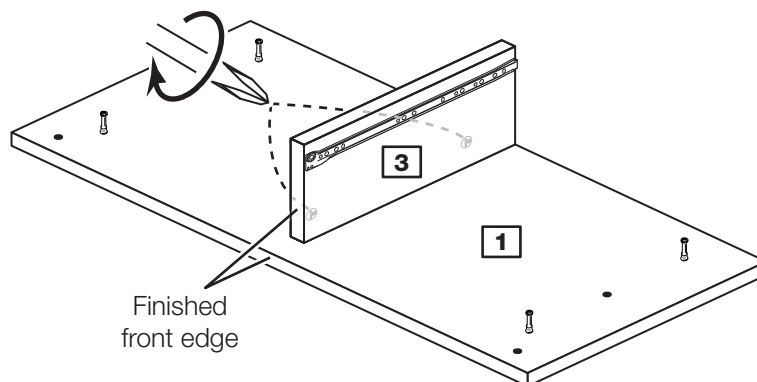

## Step 24

### Fit the top

Carefully stand the unit up for this step.

Push the top **1** down onto the assembly.

Use a screwdriver to tighten the 4 large locking nuts **C** fitted to the left side **4** and right side **5**.



**Warning:** The unit is heavy. Lift with care.

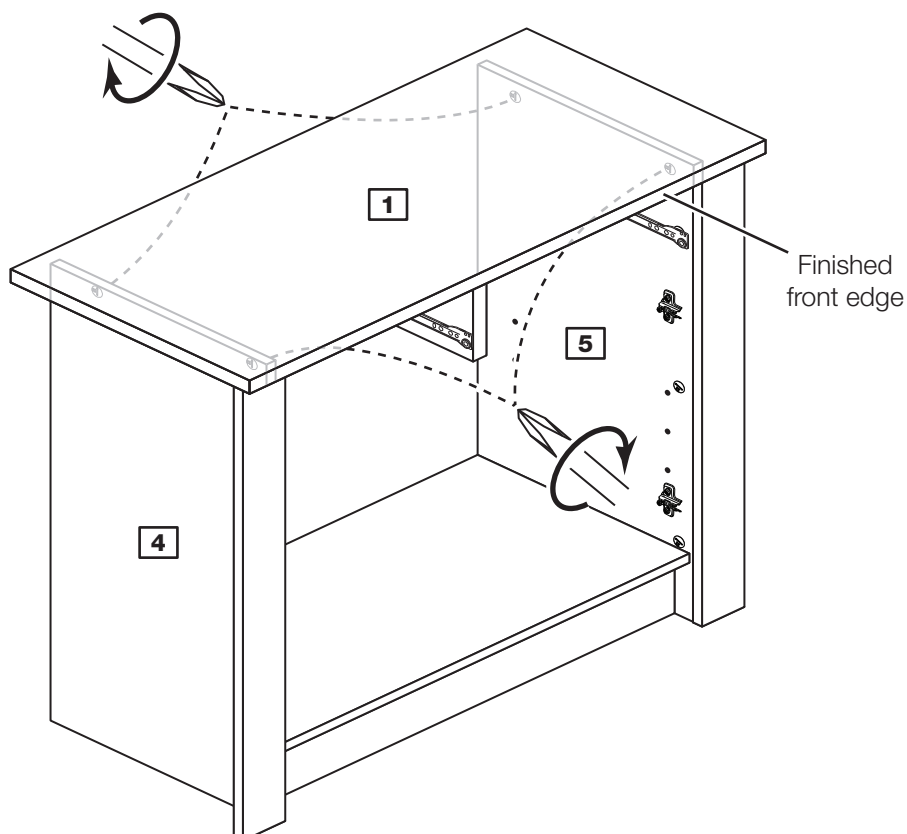

# Assembly Instructions

## Step 25

### Fit the back

Lay the unit back down for this step.

**a:** Square up the unit by making sure that measurement **x to x** equals **y to y**.

**b:** Place the back **16** onto the unit.

Nail **E** around the outside edges of the back **16**.

**Note:** Nails should be spaced about 150mm apart.

**a:** The measurement from top corner X to bottom corner X must be equal to the measurement from top corner Y to bottom corner Y

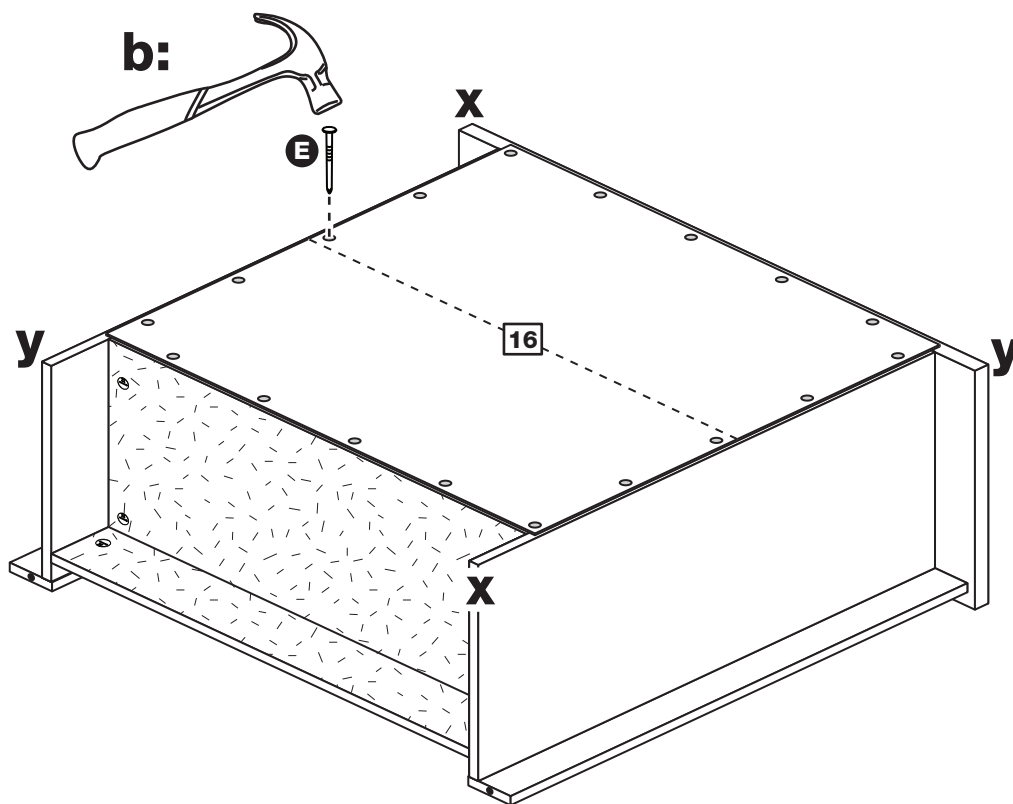

## Step 26

### Fit the 4 plastic nails

Tap 2 plastic nails **L** into the bottom edge of each of the sides **4** and **5**.

Stand the unit up for the next step.



**Warning:** The unit is heavy. Lift with care.

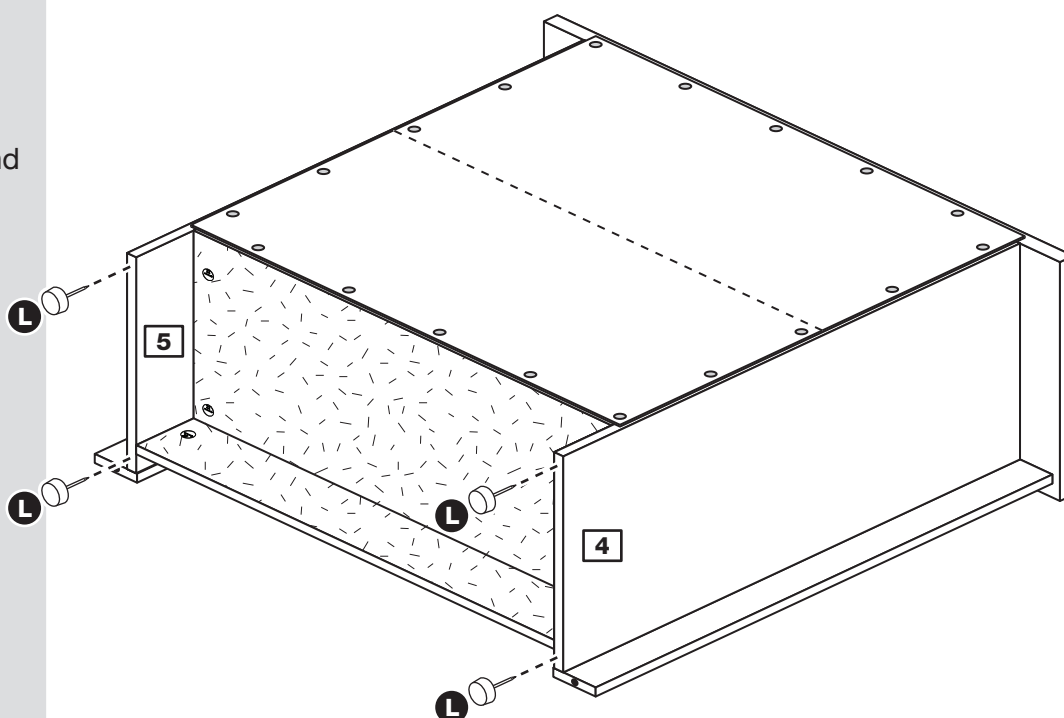



# Assembly Instructions

## Step 27

### Fit the overbalance protector

To prevent possible overbalancing we recommend that this unit is secured to a suitable wall by use of the overbalance protector kit **Q** fitted to the unit or, an alternative fixing method of your choice.

Wall fixings are not supplied as they will need to suit the wall type.

**Note:** Take care when drilling the wall that you do not drill into any pipes, wires etc. If in doubt, consult an expert.



**Warning:** The unit is heavy. Lift with care.

### Example

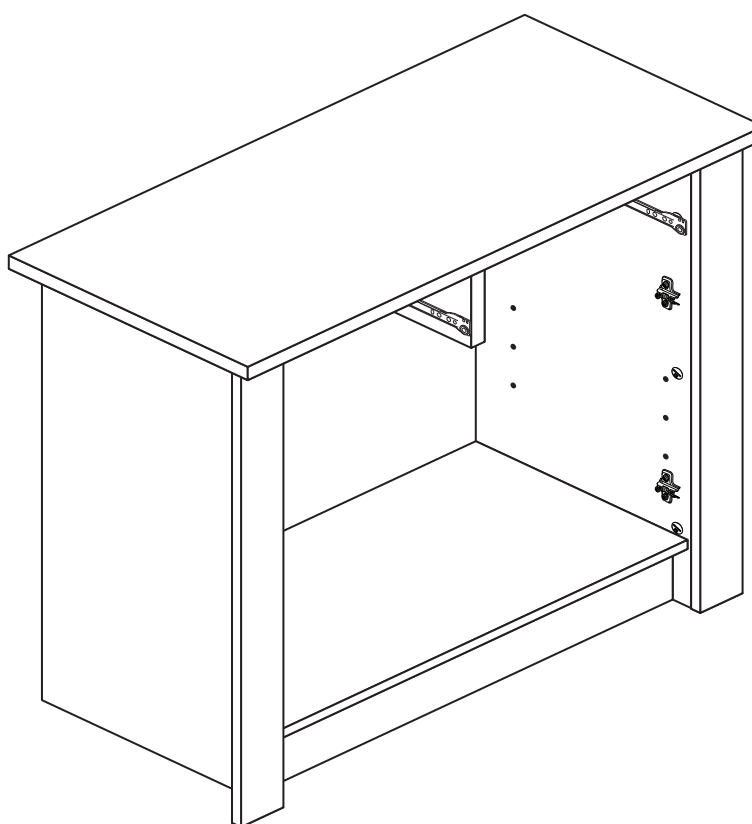
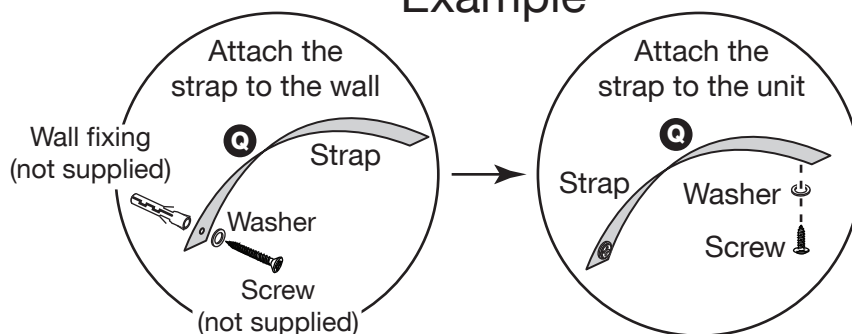

# Assembly Instructions

## Step 28

### Fit the drawers

Slide the wheels of the runners fitted to the drawers, over the wheels of the runners fitted to the side panels and push the drawers into position.

**Note:** The left drawer front has a small identification hole. Please refer back to Step 1.

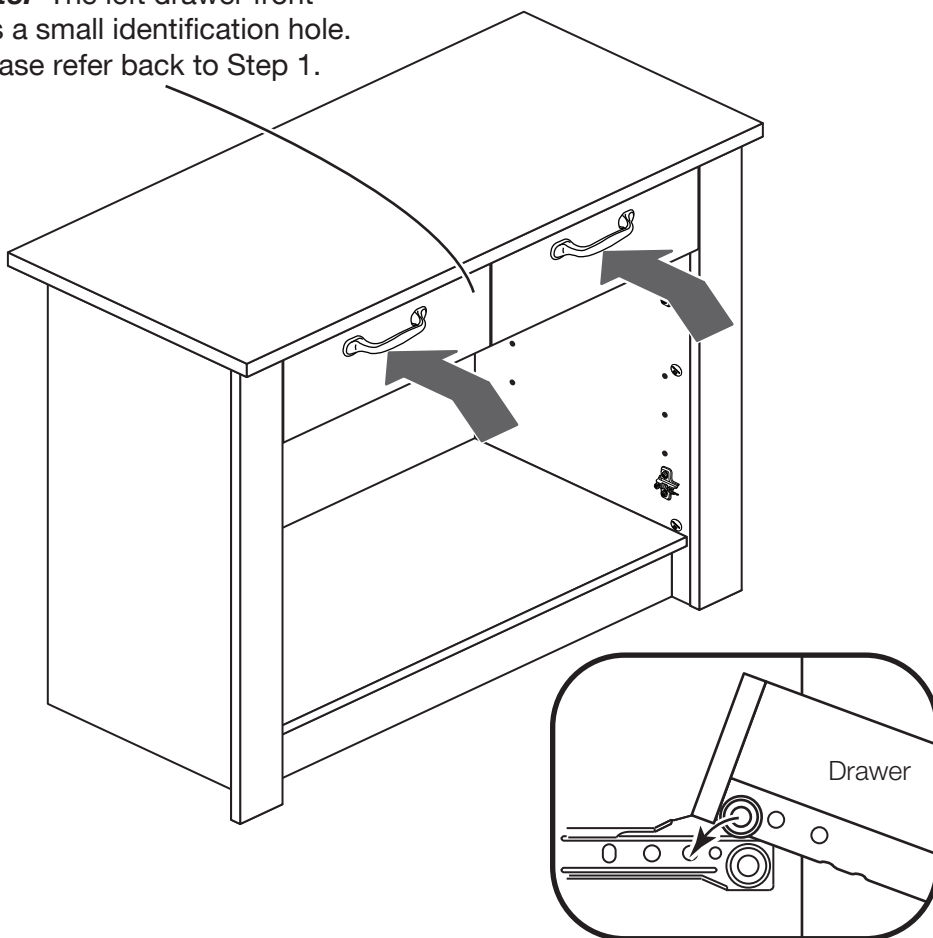

## Step 29

### Fit the shelf studs

Insert the shelf studs **F** into the holes in the left side **4** and right side **5** at the required height.

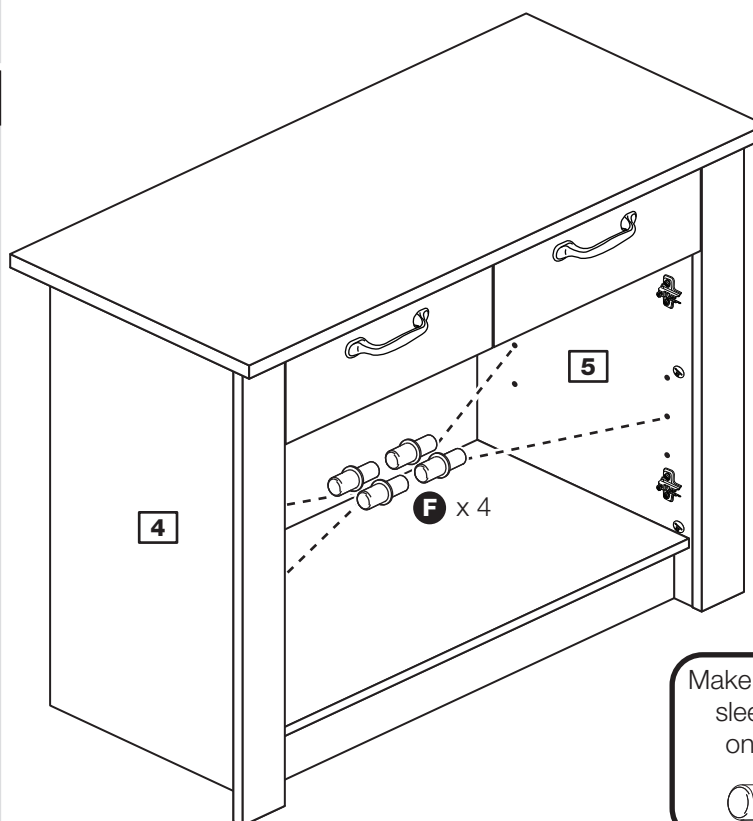

# Assembly Instructions

## Step 30

### Fit the shelf

Lower the shelf **14** down onto the shelf studs **F**.

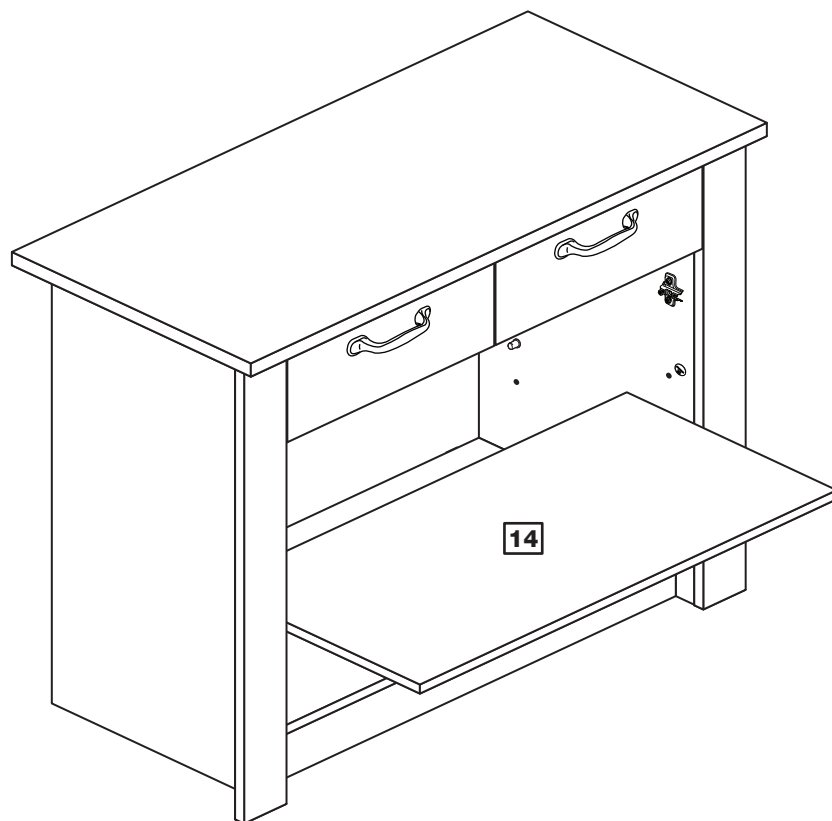

## Step 31

### Prepare the 2 doors

Push fit 2 hinges **N** into each of the 2 doors **15**.

Secure each hinge with 2 screws **K**.

**Note:** Before securing with the screws, make sure that the hinges are positioned at 90 degrees with the edge of the door.

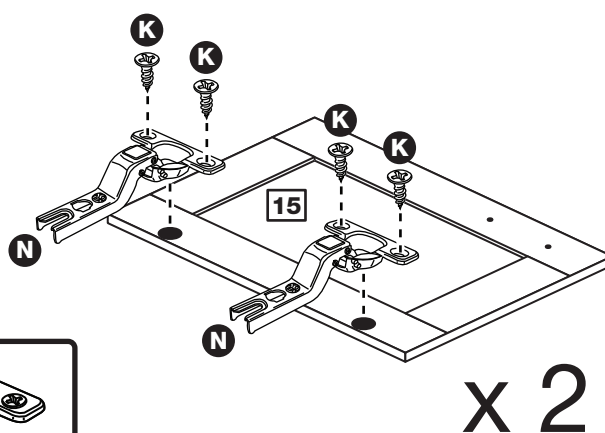
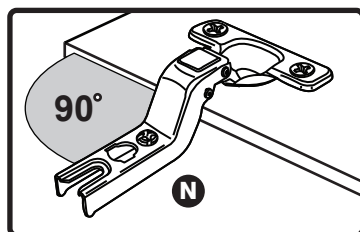

# Assembly Instructions

## Step 32

### Drill 2 handle holes in each of the doors

**Important:** Please follow these instructions carefully.

Lay the 2 doors **15** down onto a smooth surface.

Check that the hinges and holes are in the same place as the diagrams.

**Note:** We recommend the use of a small piece of waste wood, placed behind the holes while drilling, to reduce the possibility of any breakout.

Using the pilot holes in the rear face of the door, drill through the 2 holes indicated opposite, using a 2.5mm diameter drill.

Turn the door over and open out the 2.5mm holes that you have just drilled by drilling back through them with a 5mm drill.

### IMPORTANT

Carefully choose which 2 holes you need to drill in each door

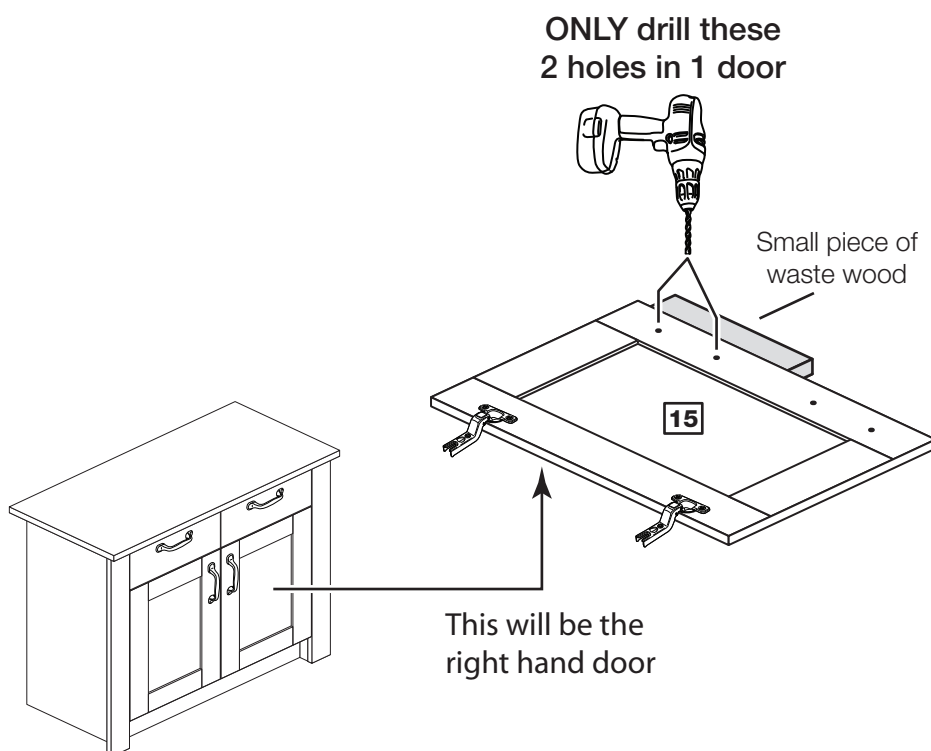
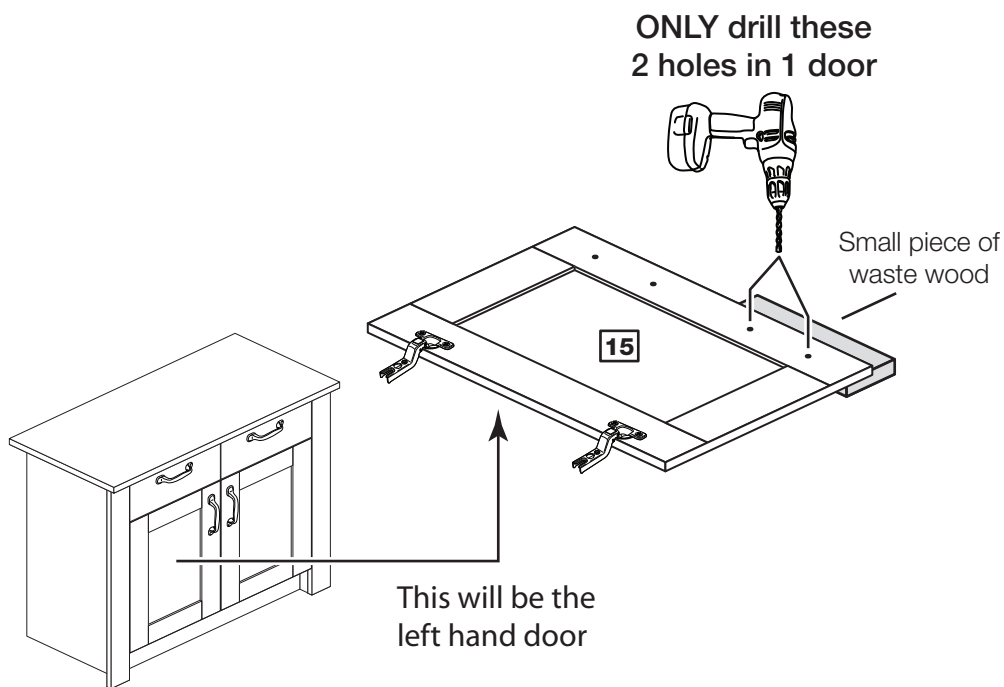

# Assembly Instructions

## Step 33

### Fit doors and handles

**Note:** The easiest way to attach each door **15** is to fit the top hinge first, then align and fit the other hinges.

**a:** Push the hinge **N** onto the front part of the hinge plate **M**. The recess at the bottom of screw B goes into the slot in the hinge plate.

**b:** Keep the hinge **N** FLAT against the hinge plate **M** as you slide it across as far as it will go. Tighten screw A.

**c:** The hinge **N** must be flat against the hinge plate **M** prior to any adjustment.

**d:** The hinge **N** must NOT be AT AN ANGLE to the hinge plate **M** when assembled. This would indicate that the recess at the bottom of screw B had not located in the slot in the hinge plate and the hinge would not be secure. Remove the hinge from the hinge plate and then re-assemble being careful to follow instructions a-c.

**e:** Attach a handle **O** to each door **15** using 2 screws **H**.

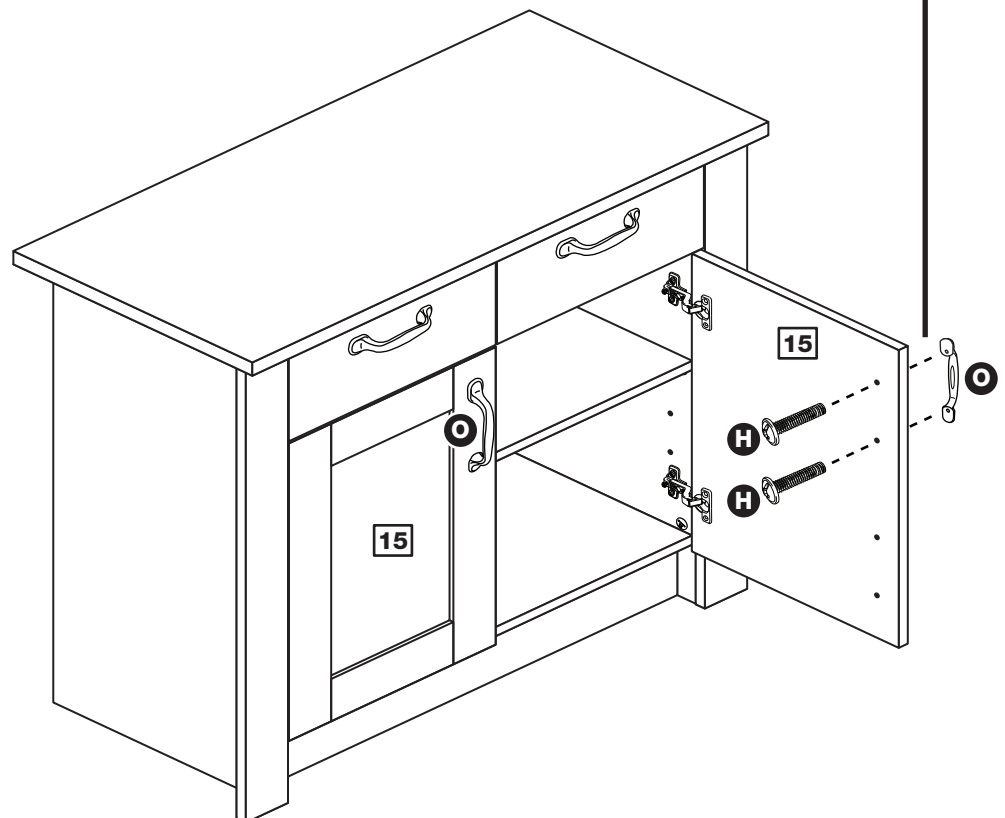
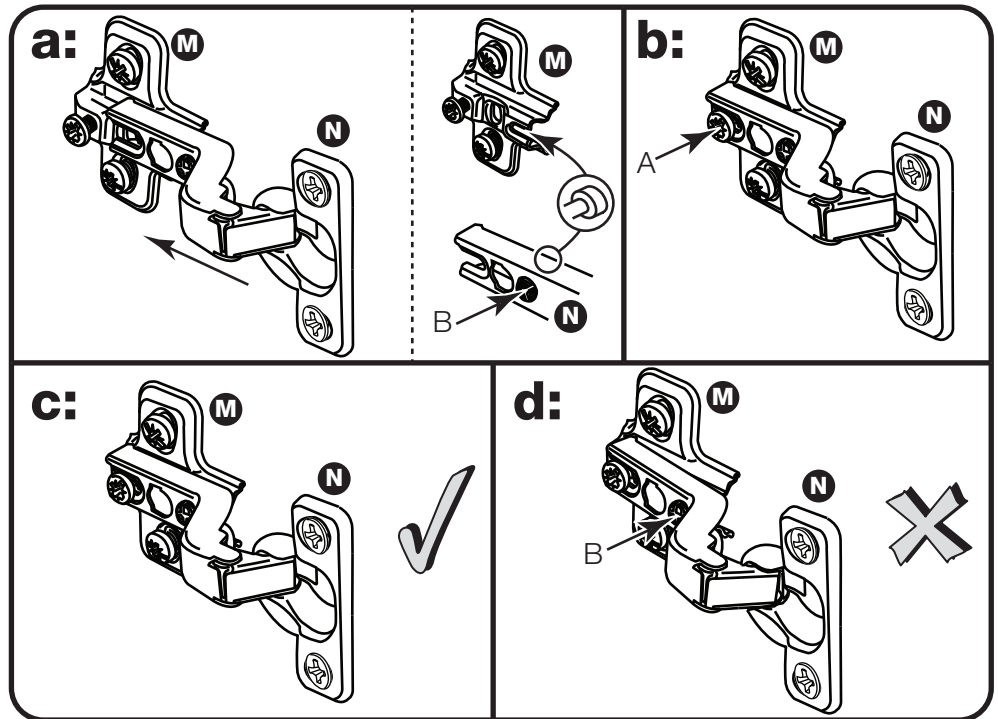

# Assembly Instructions

## Step 34

### Adjust the doors if needed

**a:** Before adjusting the doors, use a spirit level to check the base (or top) of the unit is level, front-to-back and side-to-side in the 3 positions shown. Use suitable packing pieces (not supplied) to make the unit level BEFORE making any adjustment to the hinges, as shown.

### **b:** Height adjustment.

Loosen screws A on hinge plates and move door up or down as required. Retighten screw A.

### **c:** Forward and Back adjustment.

Loosen screw B on hinge plate and move door in or out as required. Retighten screw B.

### **d:** Sideways adjustment.

To move door 'out' loosen screw C. To move door 'in' tighten screw C.

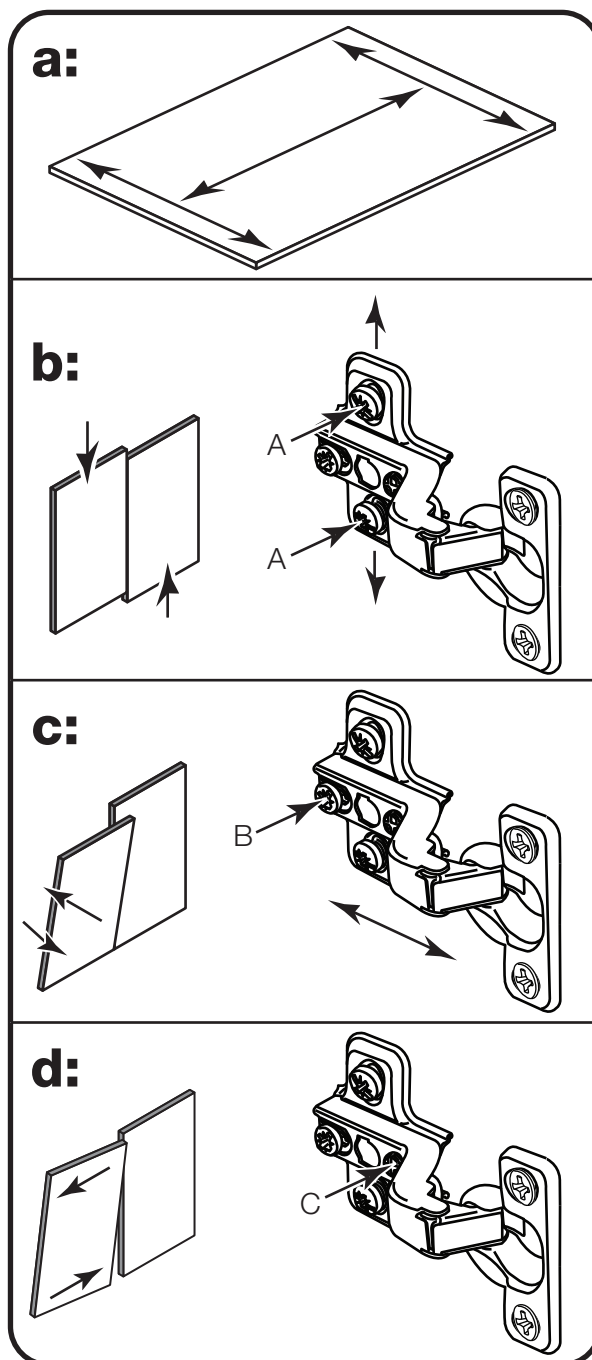

# Assembly Instructions

## Step 35

**Assembly is complete**



**Warning:** The unit is heavy. Lift with care.

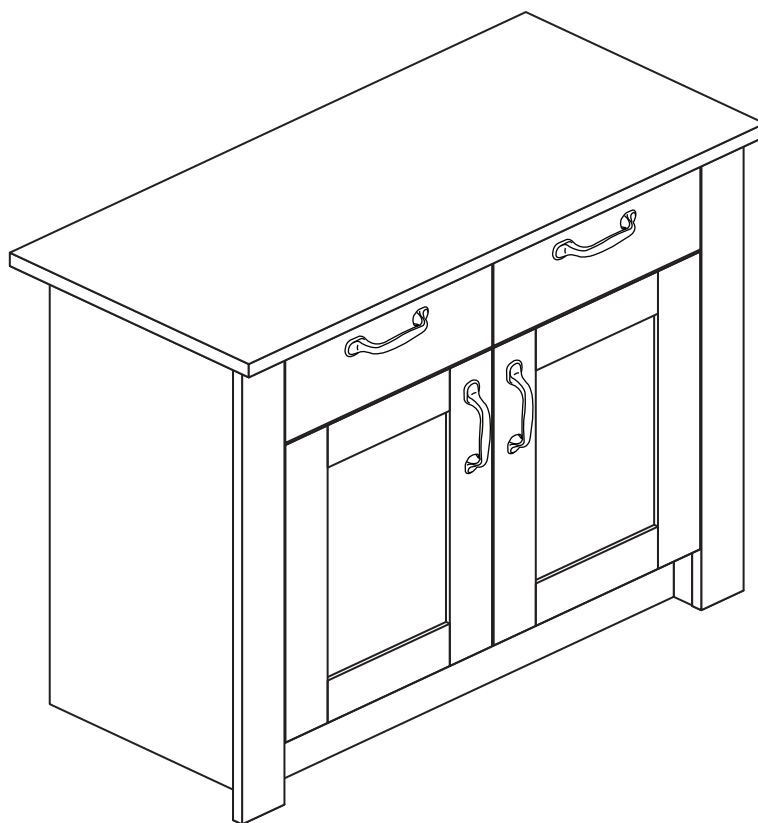

If you need help or have damaged or missing parts, call the **Customer Helpline: 08456 400800** and quote the reference numbers on the component pages.

Argos Ltd, 489-499 Avebury Boulevard, Central Milton Keynes, MK9 2NW

