

HOME

**AH Rosa 5 Light Flower Floor Lamp**  
SKU 3037472

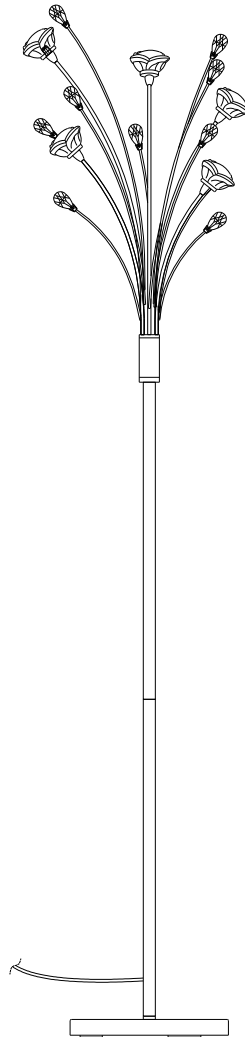

**Care & Instruction Manual**

For household and indoor use only

**Please read and retain these instructions for future reference**

## Important

- Read these instructions carefully and familiarize yourself with the procedure before assembling the unit.
- Take all the components and fittings out of the plastic bag and separate them into their groups.
- Ensure you have enough space to lay out all the parts before assembly.
- Always be sure to use the correct type and wattage of bulbs as indicated on the fitting. Never exceed the wattage stated.
- To avoid scratching it is recommended that you assemble the unit on a soft level surface.
- When changing the bulb, always switch off at the mains and allow the old bulb to cool down before handling. Dispose of used bulbs carefully.
- The external flexible cable or cord of this luminaire cannot be replaced; if the cord is damaged, the luminaire shall be destroyed.
- The luminaire is designed for indoor use only.
- This luminaire is a Class II appliance.

## Instruction to use

1. Screw tube A, tube B and tube C together.
2. Pull the external flexible cable through the bottom tube. Take care the excess cable does not become trapped or twisted when fixing tubes together. And then screw tube C onto the base (see diagram).
3. Loosen the screws on the tube using the Allen key provided but do not remove completely. Arrange the arms so they are spaced equally and tighten the screws.
4. Insert the bulbs into the lamp holder. Type and wattage as indicated on the fitting. The wattage indicated must not be exceeded.
5. Place glass shades over the light bulbs and push it onto the lamp holders.
6. Plug the floor lamp into a suitable mains socket.

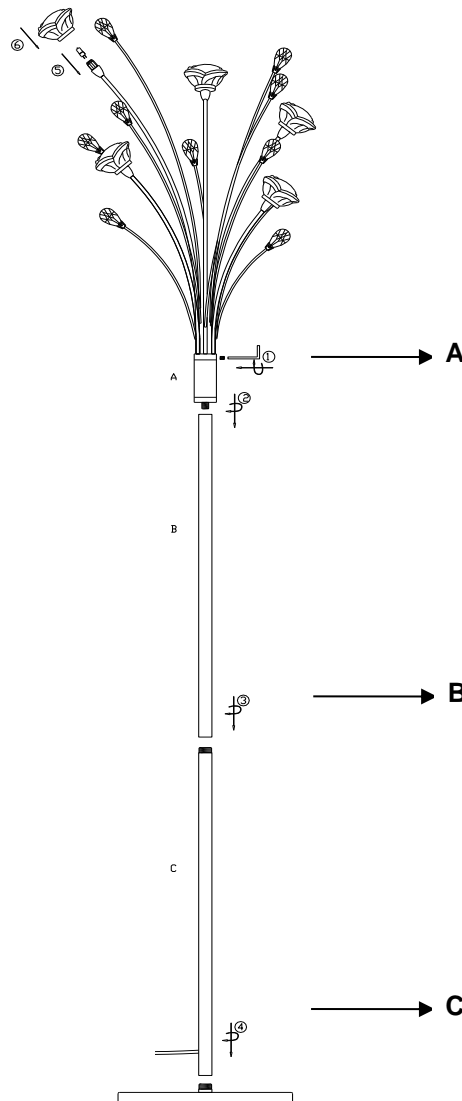

## Maintenance

This fitting is designed for indoor use only and must be fitted to a DRY SURFACE as any dampness in plaster or paint can damage the finish. Do not use polish or abrasive cleaner - just a soft dry cloth.

## Bulb Replacement

1. Switch off the mains power supply.
2. Before replacing the bulb, allow it to cool down for at least 10 minutes.
3. Never touch the bulb with your fingers directly, cover it with a cloth.
4. Loosen the bulb and remove it from the lamp.
5. Replace a new bulb with same voltage and wattage.

**(Max.2W G4 LED Bulb)**



### Recycling electrical products

You should now recycle your waste electrical goods and in doing so help the environment. This symbol means an electrical product should not be disposed of with normal household waste. Please ensure it is taken to a suitable facility for disposal.

Visit [www.recycle-more.co.uk](http://www.recycle-more.co.uk) click on "bank locator" and enter your postcode to find your nearest recycling site.



We care about our quality and what you think,  
If you have any comments, good and bad,  
Please call our Careline **Argos: 0345 6 400800**  
or visit **www.argos.co.uk**  
Your statutory rights are not affected.

Produced in China for  
Argos limited,  
489-499, Avebury Boulevard,  
Milton Keynes, MK9 2NW