

# glöw

## Marie Funky 3 Light User Instructions

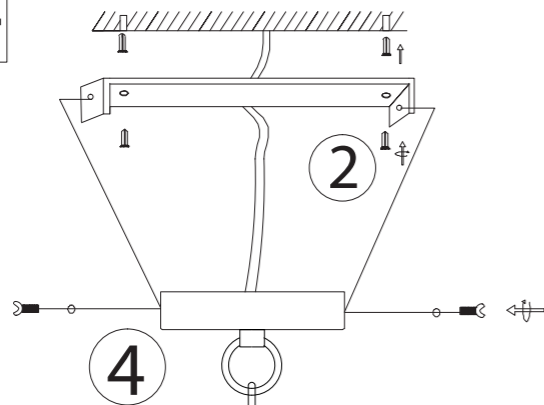
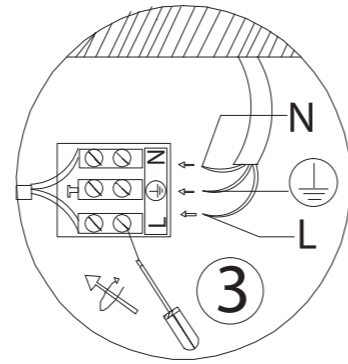
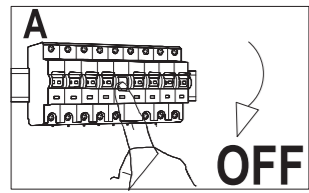

It is possible to reduce the drop of this fitting by removing links from the suspension chain and shortening the cable from the ceiling cup to the centre stem.

1. Using a pair of pliers carefully prise open the top link of chain (attached to the ceiling cup loop).
2. Slide the ceiling cup up the cable and remove.
3. Count down the chain the number of links to be removed and carefully prise open the next one available.
4. Slide the unwanted links off the cable and discard.
5. Pass the cable through the ceiling cup and attach the open link to the loop.
6. Using pliers, carefully close the open link attaching the chain to the ceiling cup.
7. Coil the excess cable inside the ceiling cup.

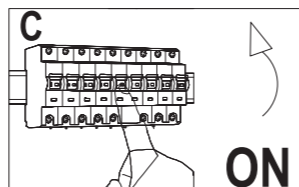
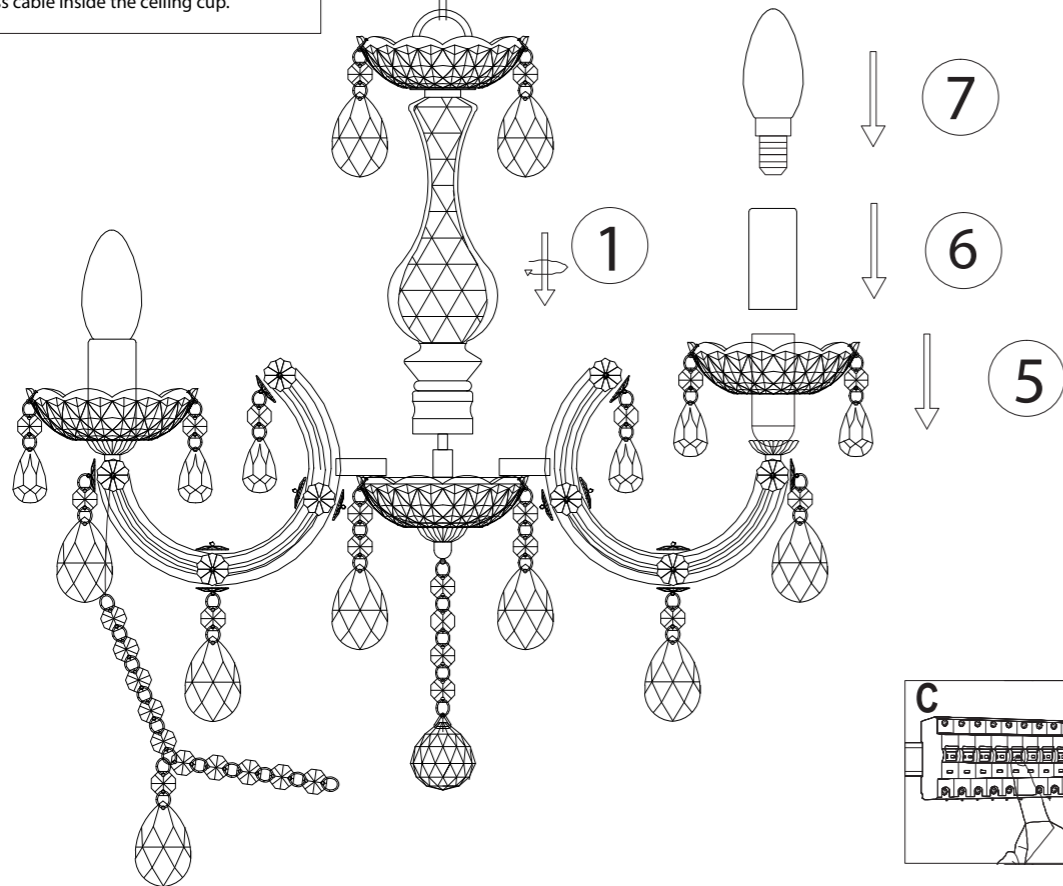

This product should be disposed of responsibly at the end of its life. Please recycle where facilities exist. Check with your Local Authority or retailer for recycling advice (Waste Electrical and Electronic Equipment Directive)

Please take time to read this leaflet carefully and retain it for future reference.

Thank you for selecting this product. It has been thoughtfully designed and carefully manufactured to ensure a high level of reliability and performance.

We strongly recommend that ceiling are installed by a qualified electrician. If, however, you decide to carry out your own installation, please read through these instructions carefully before commencing work, and retain them for future reference.

Please note, the important safeguards and instructions appearing in this leaflet are not meant to cover all possible conditions and situations that may occur. It must be understood that common sense, caution and care are factors which cannot be built into any product and must be supplied by the person installing and caring for the fitting.

### Changes to Building Regulations

As of 1 January 2005, changes to the Building Regulations affect domestic electrical installations in England and Wales. You don't need to be a qualified electrician to make changes to your home's electrical system, but the work must be done in accordance with the standards in the Regulations.

You do not need to notify your Local Authority if you do minor electrical work such as:-

- replacing or repairing a socket, light or cable in any room
- adding extra spurs, sockets or lights to an existing circuit (except in a kitchen, bathroom or outdoors)

However, the work must be done to the standards in the Wiring Regulations and you should consider having the work checked by a competent electrician to make sure it is safe.

Before you start other electrical work such as:-

- adding new circuits to your existing installation
- any work (other than repairs / replacements) in a room where there is water (eg. kitchen, bathroom, etc.)
- any work (other than repairs / replacements) outdoors (eg. installing garden lighting or sockets, etc.)

You must notify your Local Authority Building Control Department, which has responsibility for ensuring the work is inspected and tested.

Where you have any work done by an electrician who is a member of a competent person self-certification scheme, the electrician will be able to certify the work complies with the Regulations and you do not need to notify your Local Authority.

We recommend that you make yourself aware of the Regulations before you undertake any work and if you require any clarification you should contact your Local Authority Building Control Department.

### Important Safety Information

All ceiling fittings should be connected via a 5 amp fused circuit and must be installed in accordance with current applicable building and electrical installation regulations.

Before installation and servicing, disconnect the electrical supply at the mains.

Carefully observe all instructions or warnings that are labelled on, or supplied with, your product.

Unless otherwise stated, products are suitable for normal indoor use only and should not be used where water or high humidity may affect them.

If in any doubt, consult a qualified electrician.

### General Information

Do not mount ceiling/wall fittings onto damp surfaces such as newly painted or plastered areas as this may cause discolouration of the finish.

### Fixing instructions for ceiling fittings

All ceiling fittings and wall lights must be connected to the supply earth. If your lighting circuit does not have an earth, ask a qualified electrician to provide an earth facility. Make sure that there is a joist or other solid mounting at the point of fixing. This is necessary to take the weight of the fitting.

Assemble the fitting prior to connecting to the mains.

#### Ceiling cup with strap...

1-3 Taking care not to damage any house wiring, detach the mounting strap from the fitting and affix to the ceiling using the screws supplied. These screws should penetrate the joist by at least 2cm. Using the connector block supplied, connect the wires as shown on the diagram opposite. Check that you have correctly identified the house wires, that all connections are tight and that no loose strands have been left out of the connection blocks.

4-5 Offer the ceiling cup up to the mounting strap and secure in place using the screws/washers.

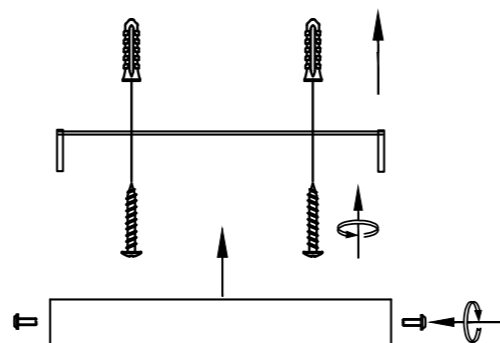

### Wiring ceiling fittings

For Earthed items (Class 1): These are marked with the symbol

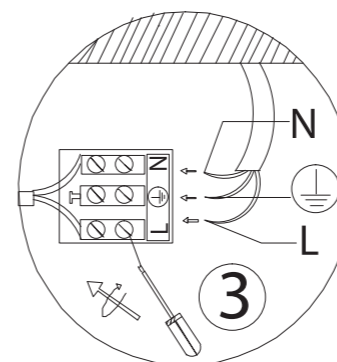

N (Neutral) = Blue

= Green/Yellow

L (Live) = Brown

Check that....

You have correctly identified the house wires.

The connections are tight.

No loose strands have been left out of the connection block.

### Selecting the correct lightbulb

Identify the correct maximum wattage and type of bulb by referring to the product labelling. (this product requires 3 x 6W Max E14 LED Candle bulbs - not included)

caution: only use a bulb of the same type designation and shape, and of the same or lower Wattage. Allow the lamp to cool for at least 10 minutes before replacing spent bulbs.

### Switch on!

You may now switch the electricity back on at the mains.

### Cleaning care

The fitting should be cleaned with a soft, dry cloth only. Do not use polishes or abrasive cloths.

### Safety information

For your safety, please remember the following:

Always switch off the supply before removing shades/covers, changing lightbulbs or cleaning.

### HELPLINE

If you receive this item with parts broken or missing, please telephone:

0333 0050077

Please have ready your name, address, tel. no., product reference, where purchased and parts required. An answering service is in operation outside office hours and during busy periods.

We regret that we are unable to give advice on internal house wiring.

Cascade Holdings Ltd. Gorse Mill, Gorse Street, Oldham, OL9 9RJ

UK  
CA

EU AUTHORISED REPRESENTATIVE:  
AUTHORISED REP COMPLIANCE  
GROUND FLOOR  
71 LOWER BAGGOT STREET  
DUBLIN  
IRELAND  
D02 P593

