

**Series 4, heat pump tumble dryer, 8 kg
WTH85223GB**



Optional accessories

WTZ11400 : Stacking kit with pull-out shelf
WTZ20410 : Stacking kit
WTZPW20D :

**The dryer for especially efficient drying:
energy efficiency class A++.**

- **Auto Dry:** automatically dries to the exact level of dryness you want.
- **Easy Clean with A++:** dries efficiently. With an easy-to-clean condenser filter.
- **Anti Vibration Design:** stable and quiet thanks to special vibration protection.
- Climate friendly dryer with the most environmental friendly cooling agent (R290).
- Easy-to-use LED display with touch control and many additional functions like start delay and remaining time.

Technical Data

Built-in / Free-standing : Free-standing
Removable top : No
Door hinge : Right
Color / Material body : White
Length electrical supply cord : 145.0 cm
Height of removable worktop : 0 mm
Dimensions of the product : 842 x 598 x 613 mm
Net weight : 48.4 kg
Drum volume : 112 l
Fluorinated greenhouse gases : No
Type of refrigerant : R290
Hermetically sealed equipment : Yes
Connection Rating : 625 W
Fuse protection : 10 A
Voltage : 220-240 V
Frequency : 50 Hz
Drying process : automatic
Capacity cotton - NEW (2010/30/EC) : 8.0 kg
Energy efficiency rating : A++
Energy consumption electric dryer, full load - NEW (2010/30/EC) : 1.87 kWh
Standard cotton programme time at full load : 205 min
Energy consumption electric dryer, partial load - NEW (2010/30/EC) : 1.14 kWh
Standard cotton programme time at partial load : 130 min
Weighted annual energy consumption, electric dryer - NEW (2010/30/EC) : 236.0 kWh/annum
Power consumption in off-mode - NEW (2010/30/EC) : 0.10 W
Power consumption in left-on mode - NEW (2010/30/EC) : 0.75 W
Weighted programme time : 162 min
Condensation efficiency class - NEW (2010/30/EC) : B
Average condensation efficiency full load (%) : 81 %
Average condensation efficiency partial load (%) : 81 %
Weighted condensation efficiency (%) : 81 %



Series 4, heat pump tumble dryer, 8 kg WTH85223GB

The dryer for especially efficient drying: energy efficiency class A++.

Performance

- Energy Efficiency Class¹: A++
- Energy²: 236 kWh
- Capacity: 1 - 8 kg
- Programme time³: 205 min
- Noise level: 65 dB (A) re 1 pW
- Condensation efficiency class⁴: B
- Condensation efficiency⁵: 81 %

Programmes/functions

- Standard programmes: cotton, easy care
- Special programmes: Woollens, Mixed Load, Towels, Timed programme warm, Timed programme cold, Sportswear, Down, Super Quick 40, shirts/blouses

Key features

- Touch control buttons: Low heat, Reduced ironing, Drying time, Fine-tuning for drying level, 24 h, end Time Delay

Additional features

- EasyClean filter
- Fully electronic control dial for sensor drying programmes and timed programmes
- Fully electronic control dial for sensor drying, including timed and special programmes
- LED Display for remaining time and 24 hours time delay, programme status indication, special functions
- Sensitive drying: large stainless steel drum with textile care and revolution drying system
- AntiVibration design: for greater stability and quietness
- No
- Container for condensed water
- Full container tank indicator
- Warning for fluff filter and condensed water filter
- no
- Child Lock
- Anti-crease cycle at the end of the programme
- Buzzer to indicate the end of cycle
- Glass door, silver-white
- AU
- Door hinge: right-hand
- Metal door catch

Technical Information

- slide-under installation
- Dimensions (H x W): 84.2 cm x 59.8 cm
- Appliance depth: 61.3 cm
- Appliance depth incl. door: 66.5 cm
- Appliance depth with open door: 110.5 cm
- Heat pump technology with climate friendly cooling agent

¹ At a range of energy efficiency classes from A+++ to D

² Energy consumption kWh per year, based on 160 drying cycles of the standard cotton programme at full and partial load, and the consumption of the low power modes

³ Programme time of the standard cotton programme at full load

⁴ On a condensation efficiency class scale from A to G

⁵ Weighted condensation efficiency for the standard cotton programme at full and partial load

**Series 4, heat pump tumble dryer, 8 kg
WTH85223GB**

Measurements in mm

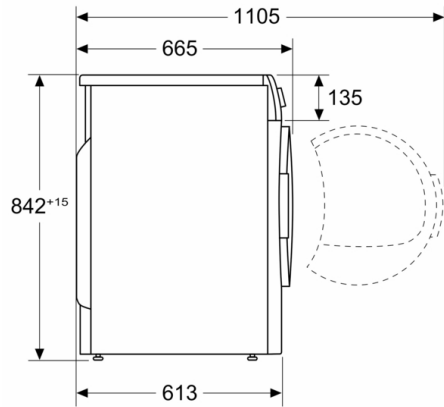

Measurements in mm

