

EN

Thank you for buying smarTrike,
If you have any assembly issues or are missing a
part, please call us for assistance. Our smarTrike®
assembly experts will assist you.

DO NOT RETURN TO THE STORE

If you are experiencing problems with this
product, please call our HELP LINE.

**USA : 1-855-SMTRIKE
(1-855-768-7453)**

The Original
smarTrike®

www.SmartTrike.com



www.youtube.com/user/SmartTrikeOfficial

SP

Gracias por comprar smarTrike,
Si tiene algún problema de montaje o
le falta una pieza, llámenos para asistencia.

Nuestros expertos en
ensamblaje smarTrike® lo ayudarán.

NO REGRESAS A LA TIENDA

Si tiene problemas con este producto,
llame a nuestra LÍNEA DE AYUDA.

para asistencia y consejo.

Estados Unidos :

1-855-SMTRIKE (1-855-768-7453)



**6 in 1
10m-36m**

502

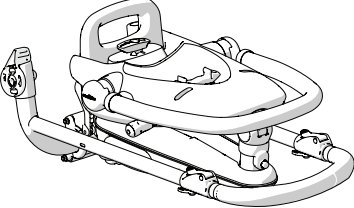
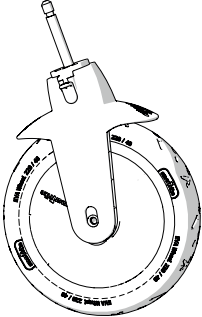
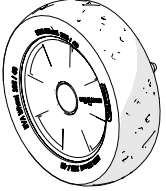
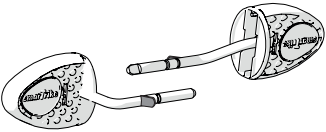

50202A

Parts included / Piezas para el montaje

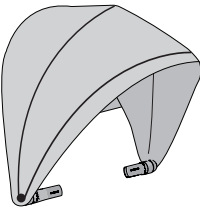
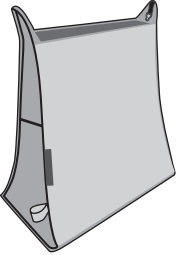
1 L502100  A	L300120  B	L505131  X2 C
L502120  D	2 12629996  E	
3 L505171  F	L550360  G	

1

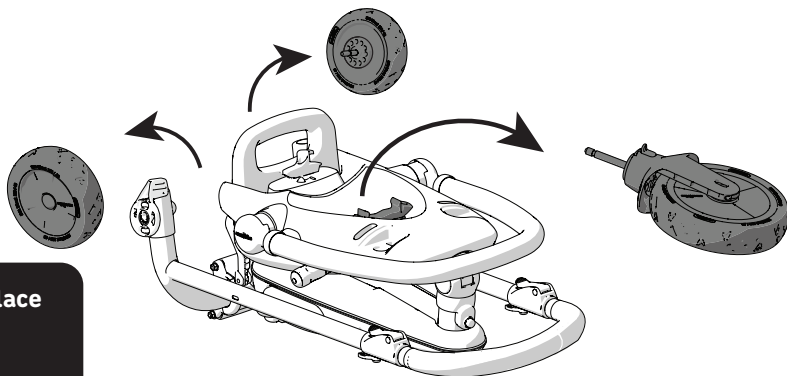

Take the wheels out and place them next to the trike.

Saque las ruedas y colóquelas al lado.

2a

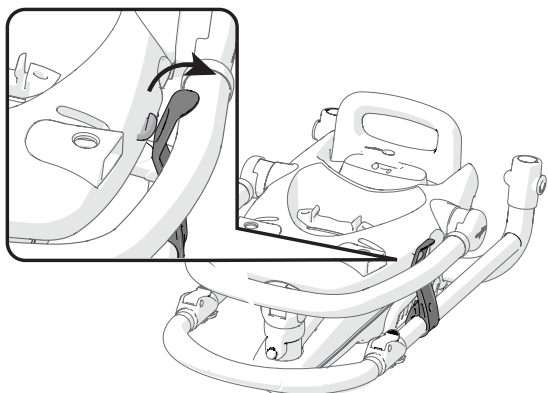

Release the latch on the side of the frame.

Abra la pestaña del costado del marco.

2b

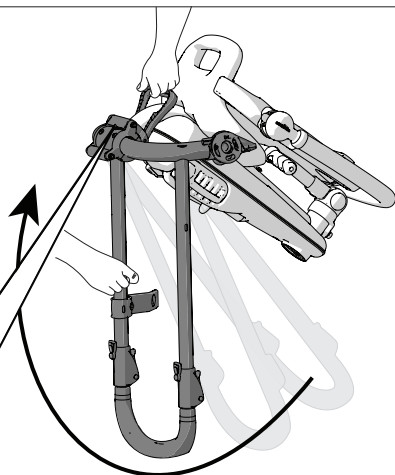

Rotate the parent handle in the direction of the arrow until it clicks into place.

Gire el manillar parental en la dirección de la flecha hasta que que escuche un clic .

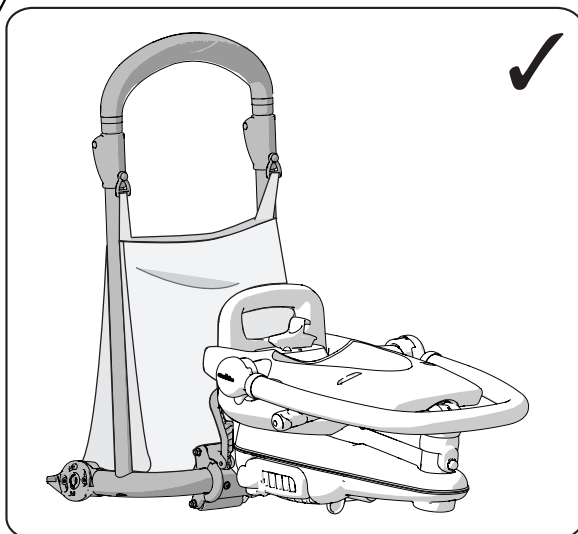
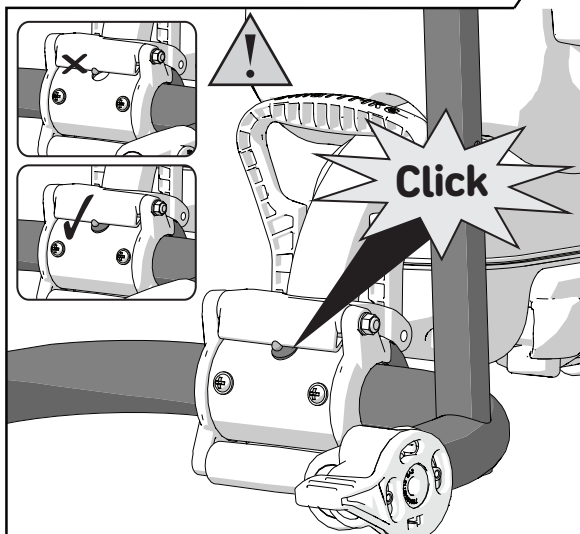

3

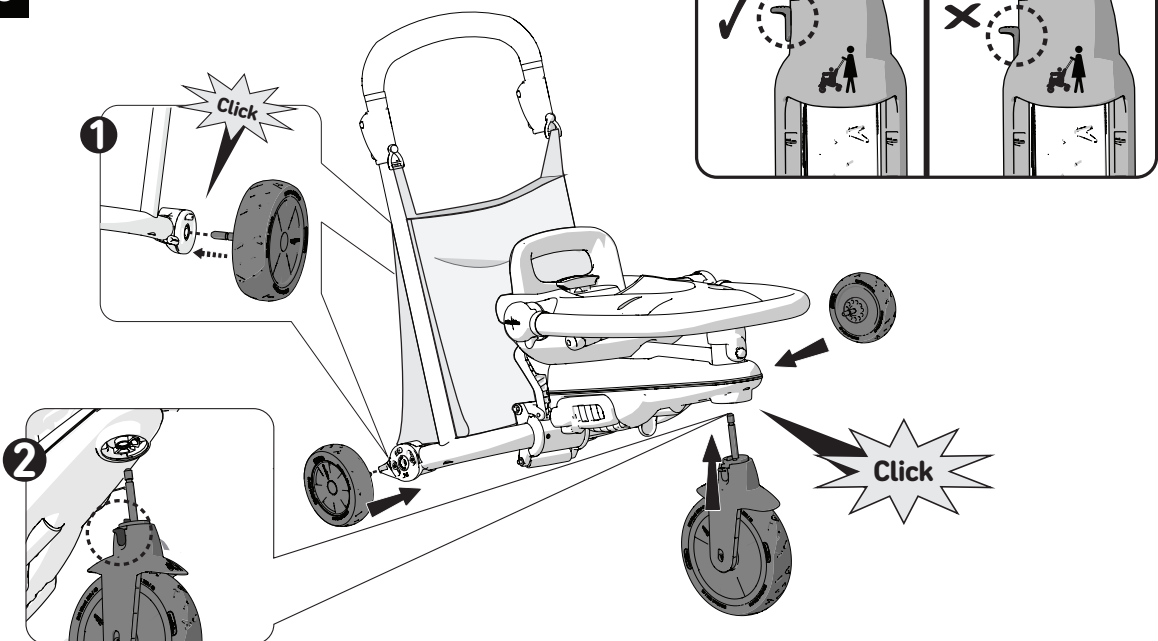

Click the wheels onto the frame.

Coloque las ruedas, deberá escuchar un clic.

4a

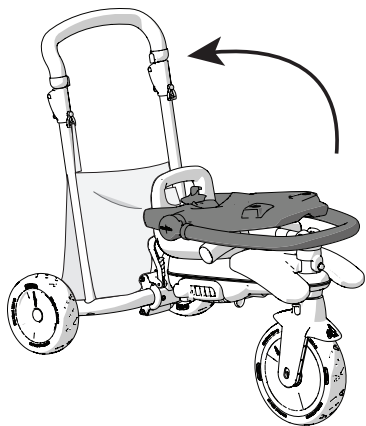

4c

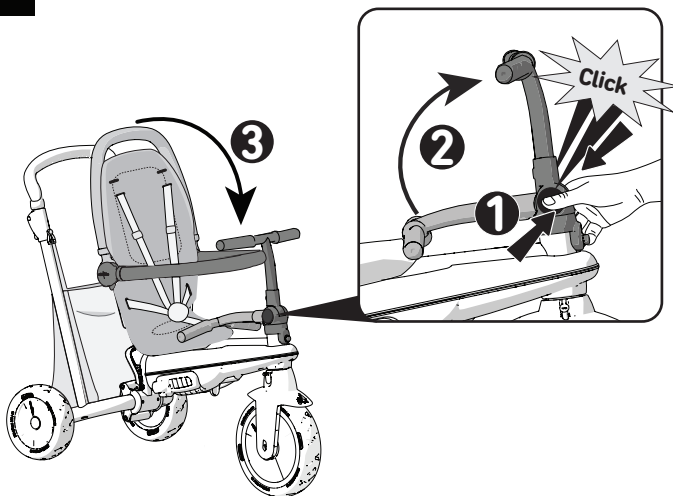

4b

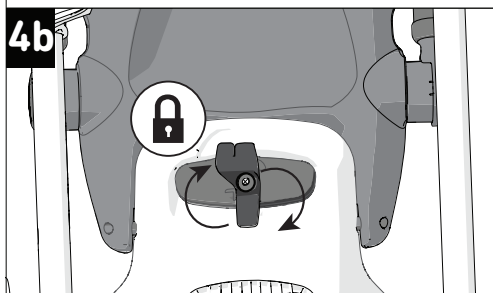

Push the buttons on the side of the handlebar together to lift the handlebar up.

Coloque el manillar en su lugar apretando al mismo tiempo los dos botones que se encuentran en los laterales.

5

1. Release the red levers on either side of the parent handle.
2. Pull the handle all the way up until you hear a click.
3. Lock the levers and you are ready to ride.

1. Suelte las palancas rojas a cada lado del manillar principal .
2. Tire del asa hacia arriba hasta que escuche un clic.
3. Bloquee las palancas.

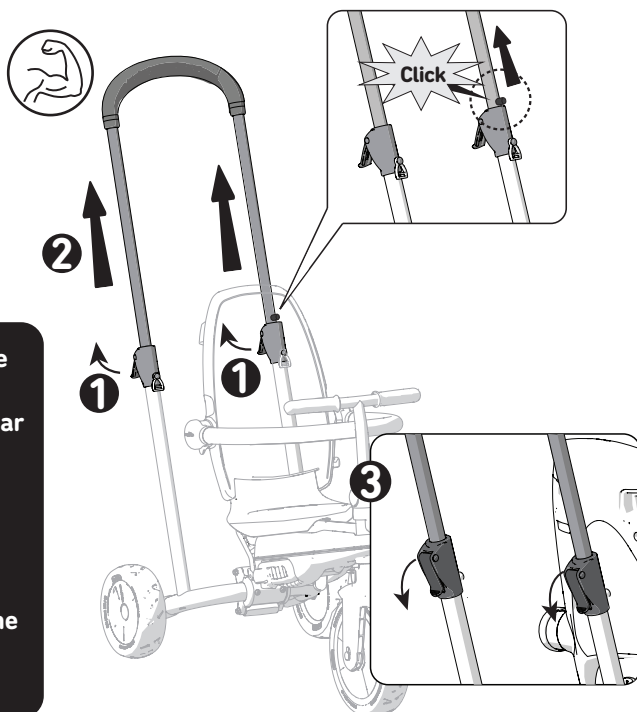

You are ready to ride / Está listo para usar

6

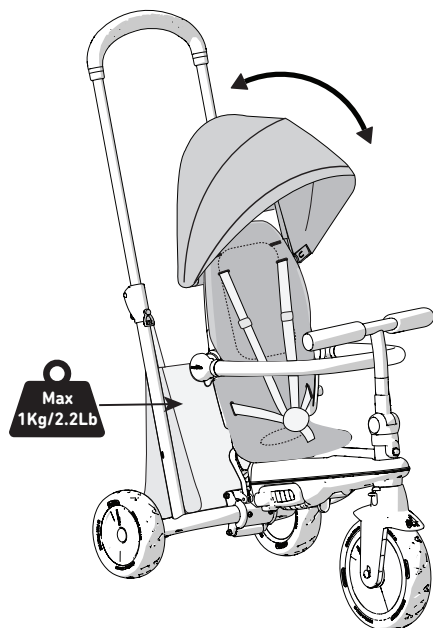
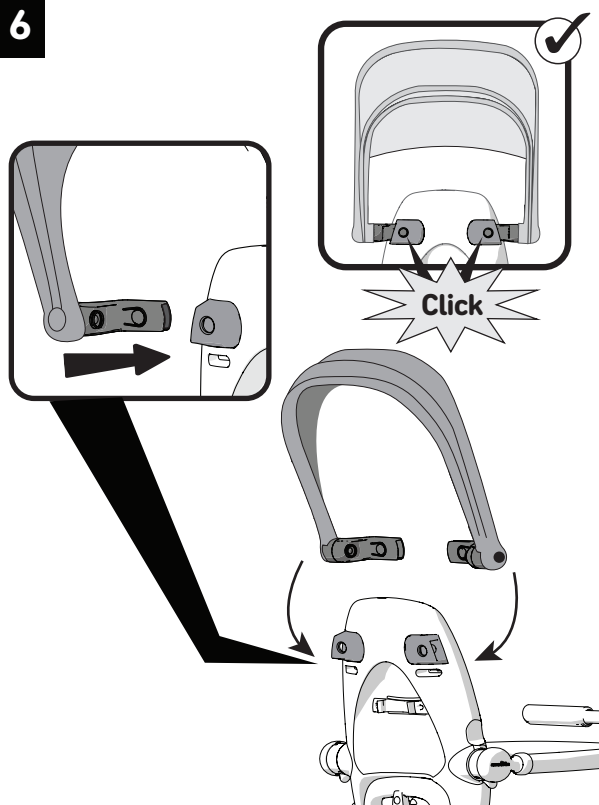

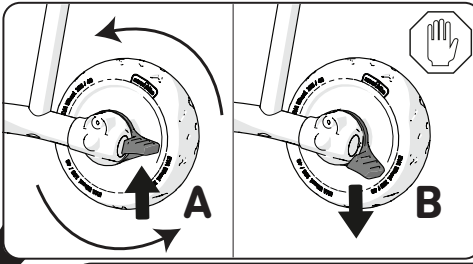
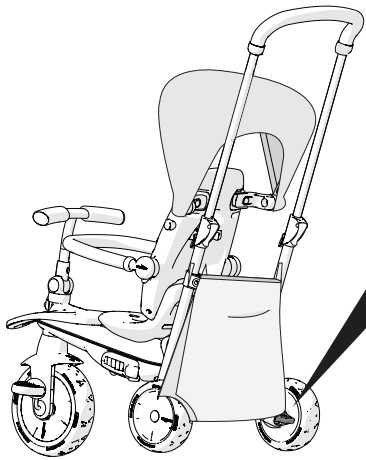

(A) Pull the brake upwards to ride.

(A) Para usarlo, empuje el freno hacia arriba.

(B) To stop, push the brake downwards.

(B) Para frenar y detenerse, presione el freno hacia abajo.

Adjust the harness / Ajuste la altura adecuada de las cintas de seguridad

⚠ WARNING! Use this harness at all times .

⚠ ¡ADVERTENCIA! Utilice siempre el arnés de seguridad .

10M+

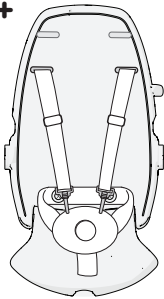

1

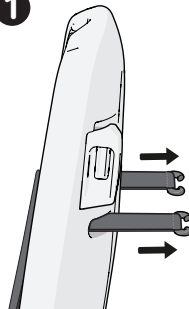

2



3

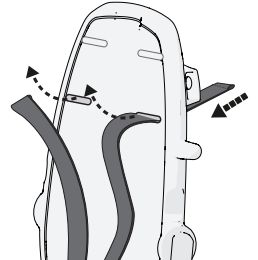

18M+

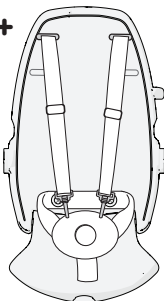

4

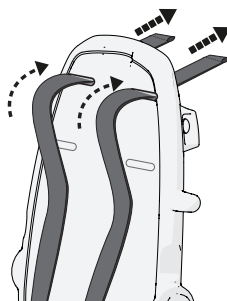

5

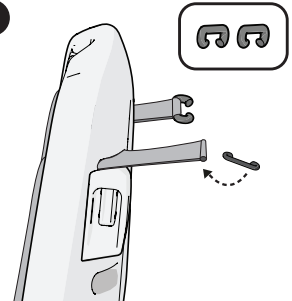

2. Release the plastic parts attached to the straps.

3. Pull the straps outward in the direction of the arrow.

4. Pull the straps through the top slots on the back of the seat.

5. Put the plastic parts back.

2. Retire las partes plásticas conectadas a los cinturones de seguridad.

3. Tire de los cinturones de seguridad hacia afuera en la dirección indicada por las flechas.

4. Inserte las correas en los dos espacios provistos arriba en el respaldo del asiento.

5. Coloque las partes plásticas nuevamente en las correas.

Usage / Uso 10M+

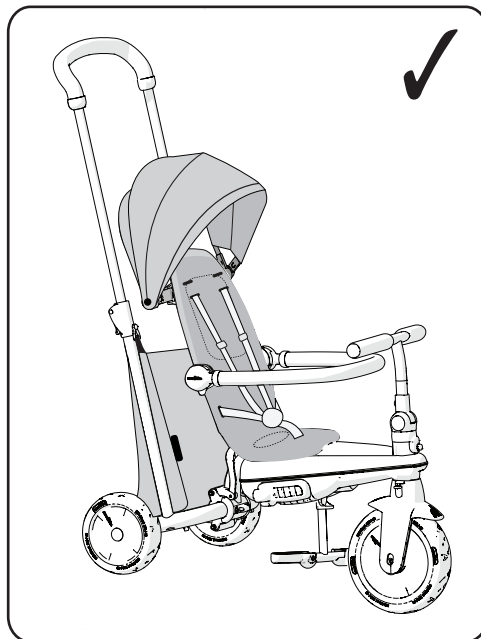
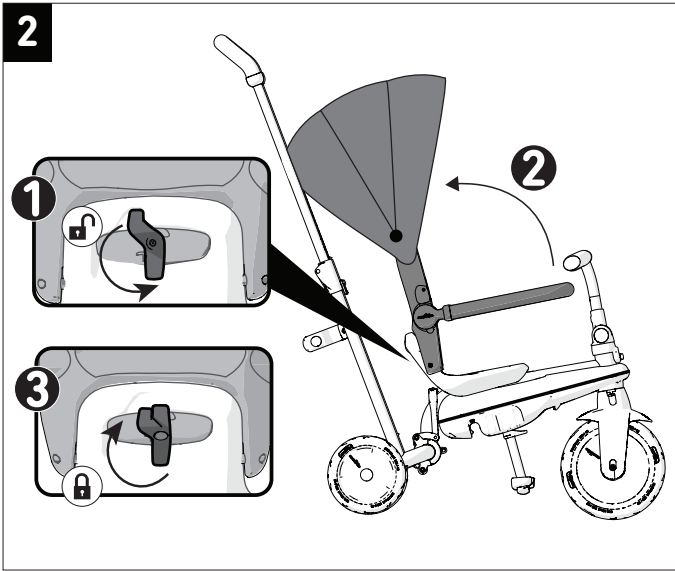
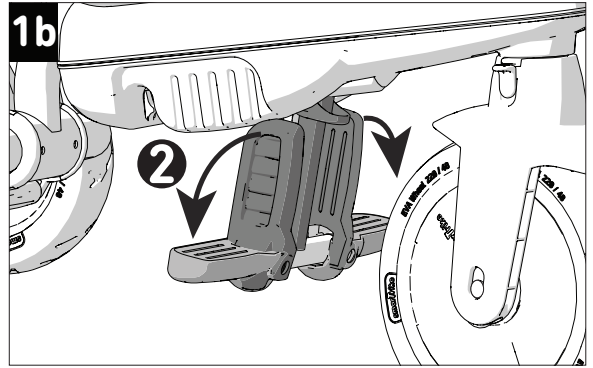
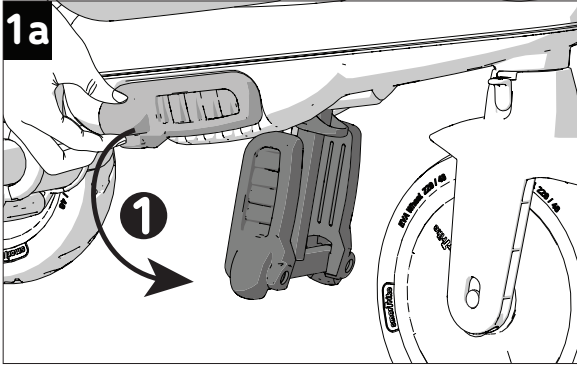

3

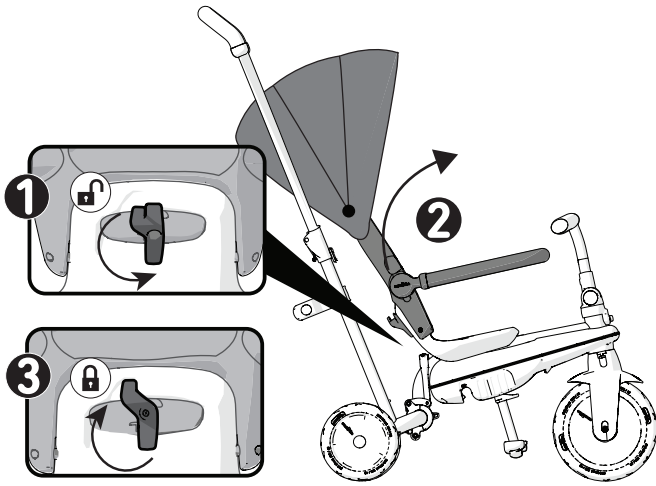

Usage / Uso 18M+

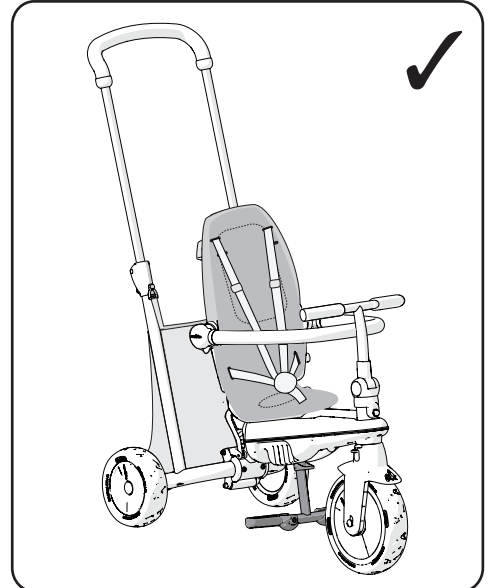
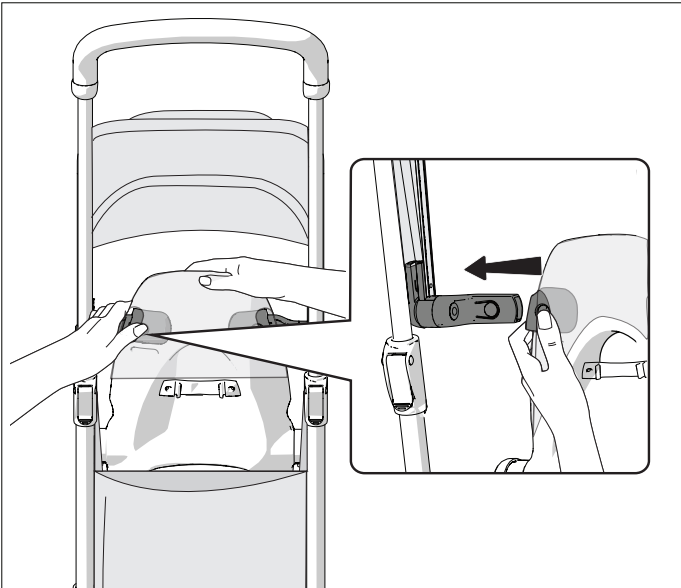

Usage / Uso 24M+

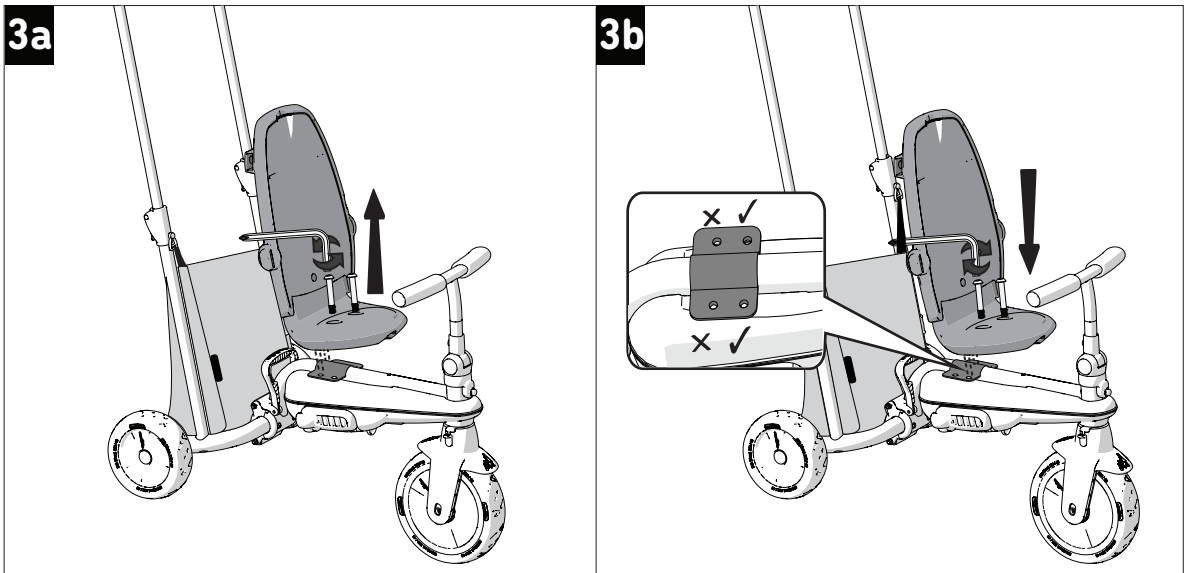
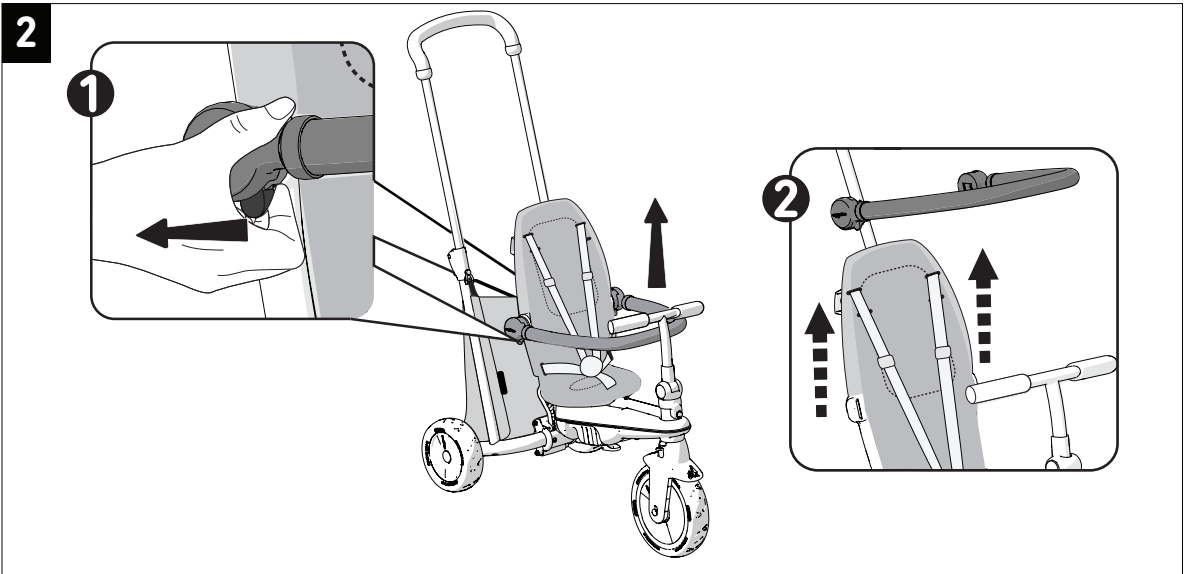
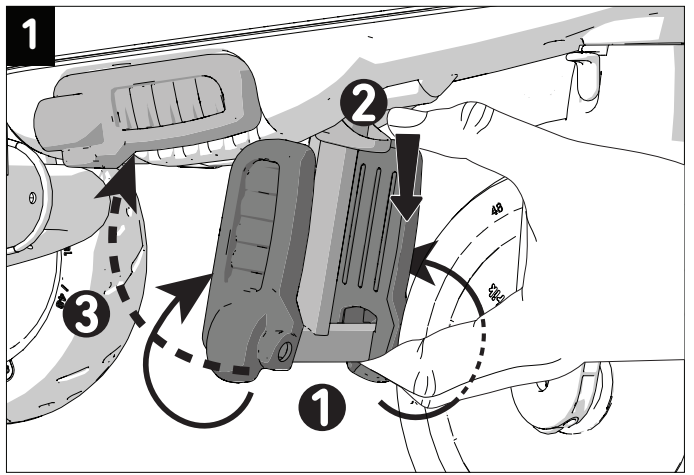

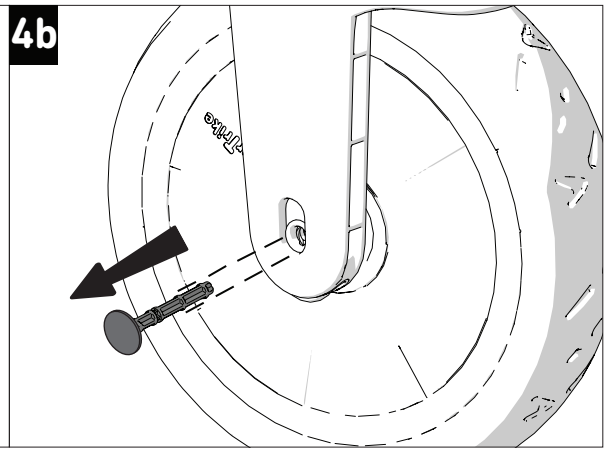
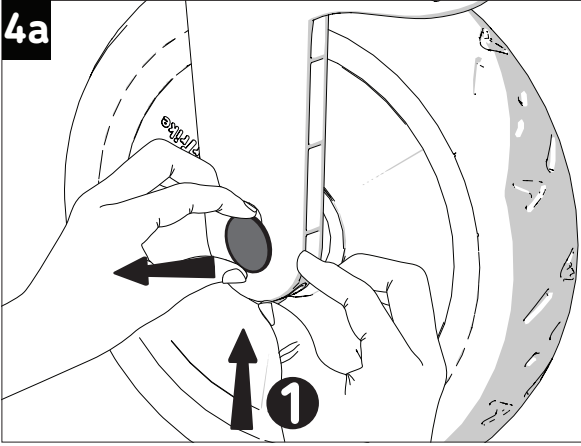

5a Practice pedaling: Attach the pedals with one click.
 Para practicar el modo pedaleo sin pedaleo, coloque los pedales en la primera posición, escuchando un solo click

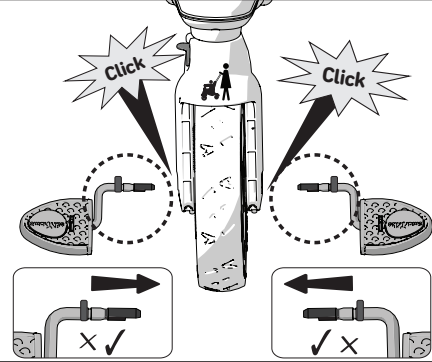
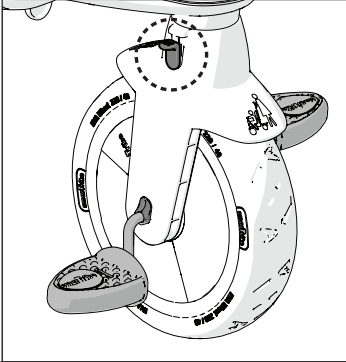

5b Independent pedaling: Attach the pedal and turn until you hear a second click.
 Para que el niño pedalee por sí mismo: empuje el pedal hacia adentro hasta escuchar un segundo clic.

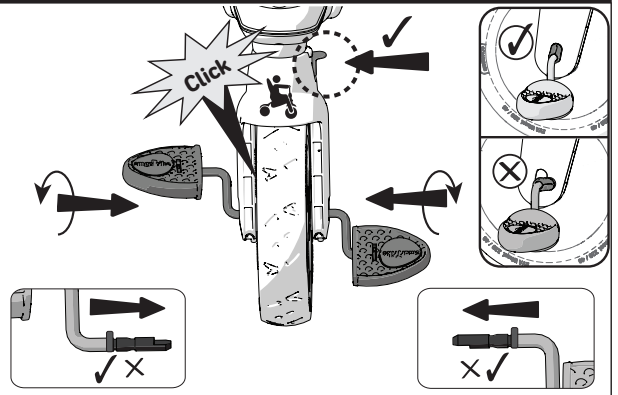
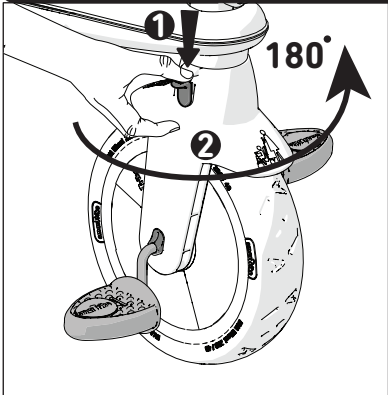



Usage / Uso 30M+

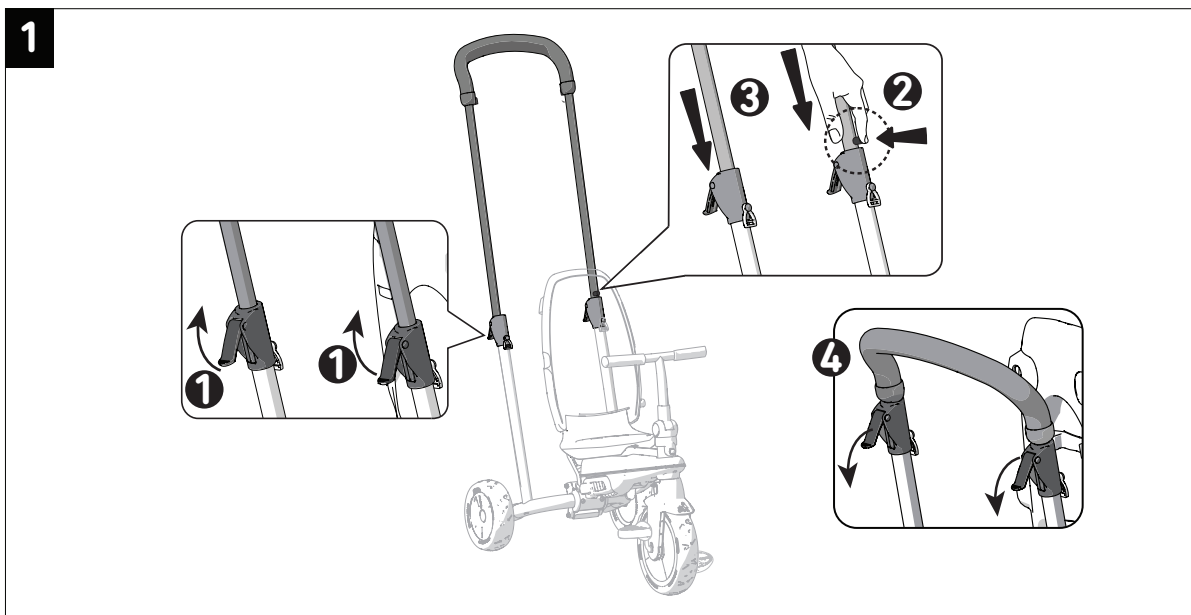

2

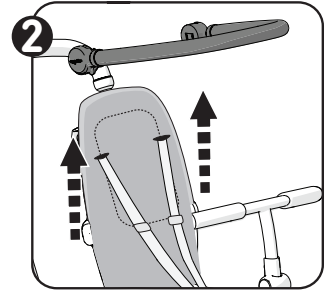
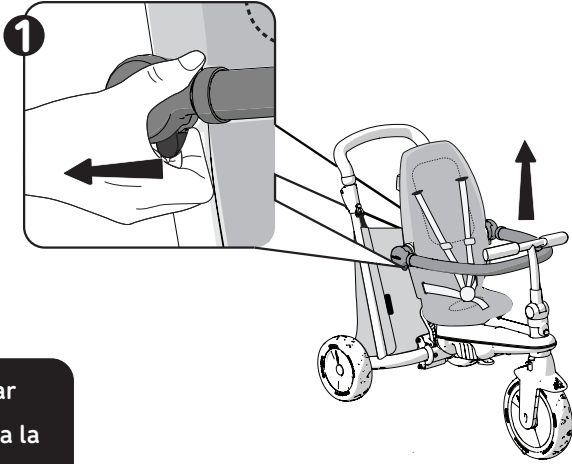

Lift up the safety bar
 Levante hacia arriba la barra de seguridad.

3

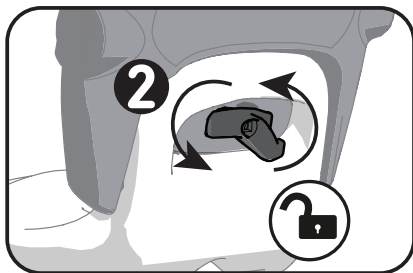
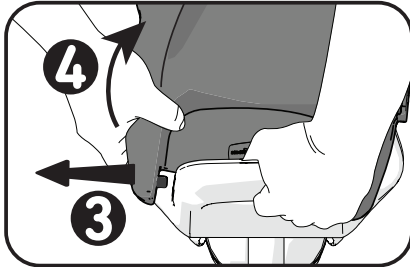
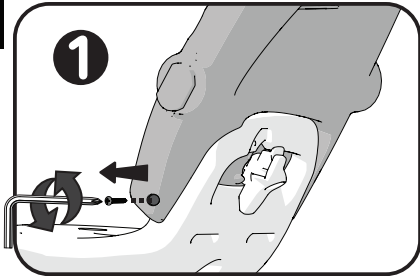

4

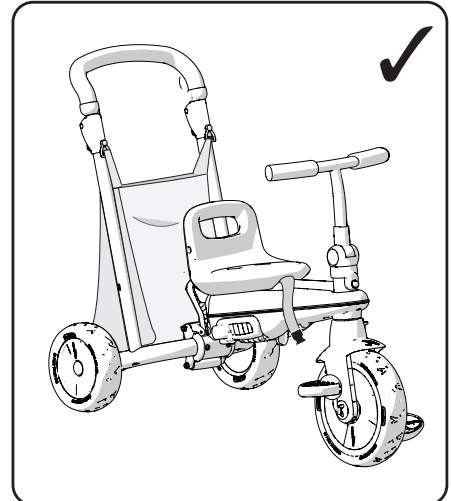
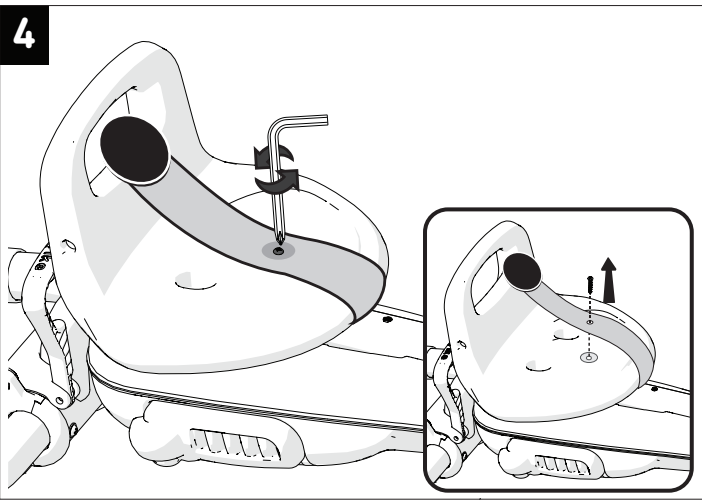

Folding instructions

Instrucciones para el plegado

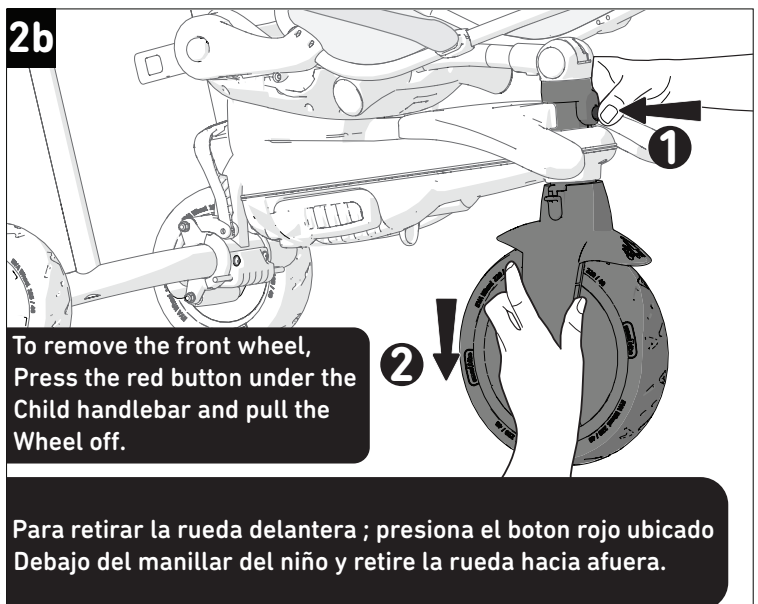
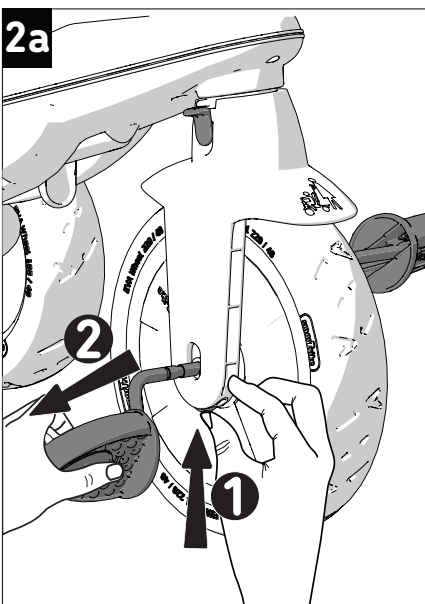
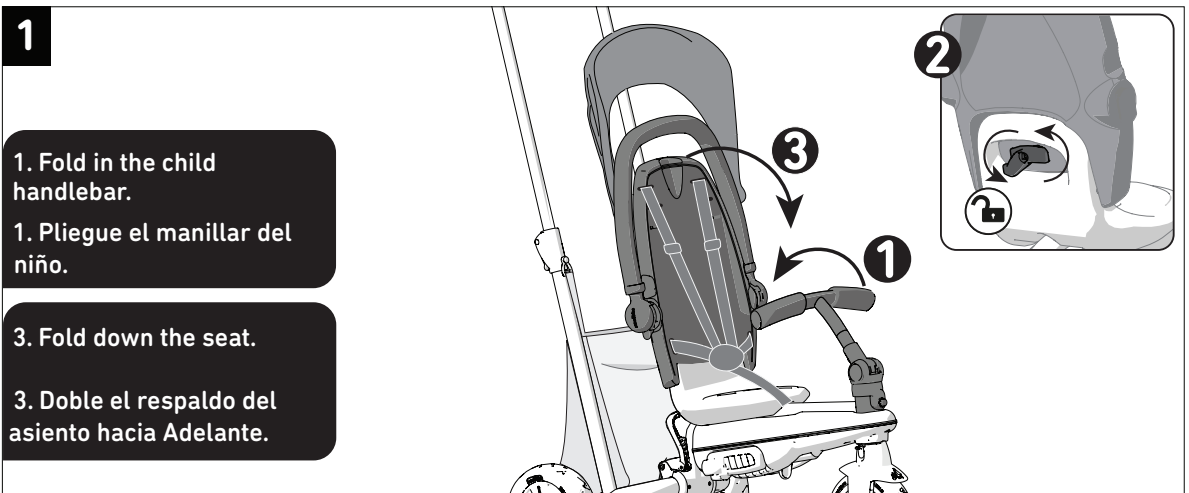

1. Pull out the pin.

1. Tire del pasador.

2. Pull the lever on the back of the frame and turn the parent Handle in the direction of the Arrow.

2. Tire de la palanca del asiento trasero y gire el manillar parental en la dirección que indica la flecha.

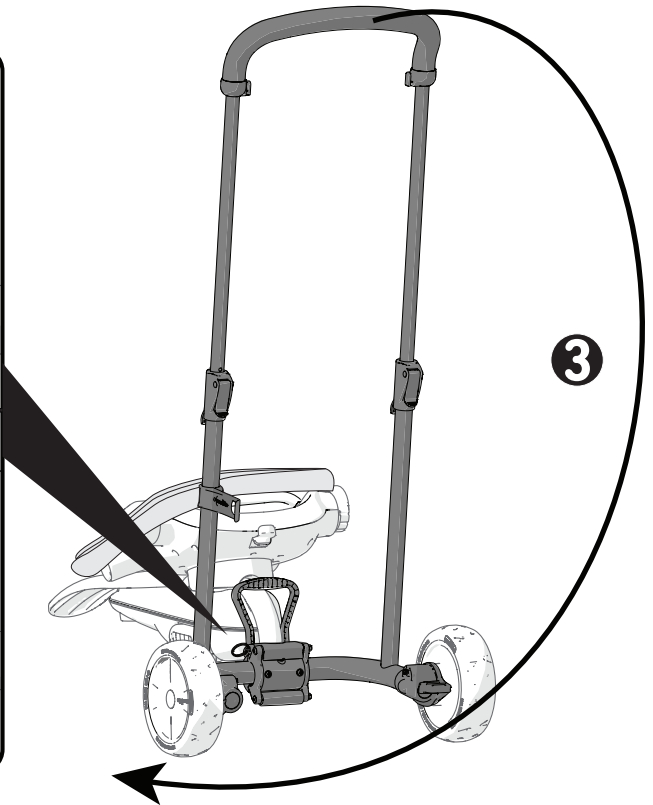
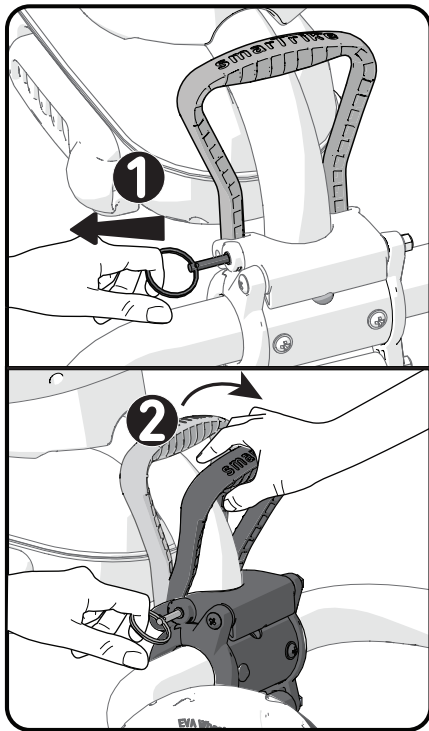

4

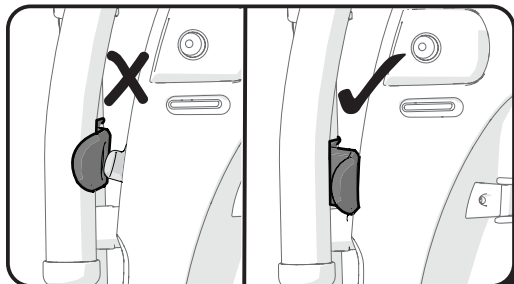

Click

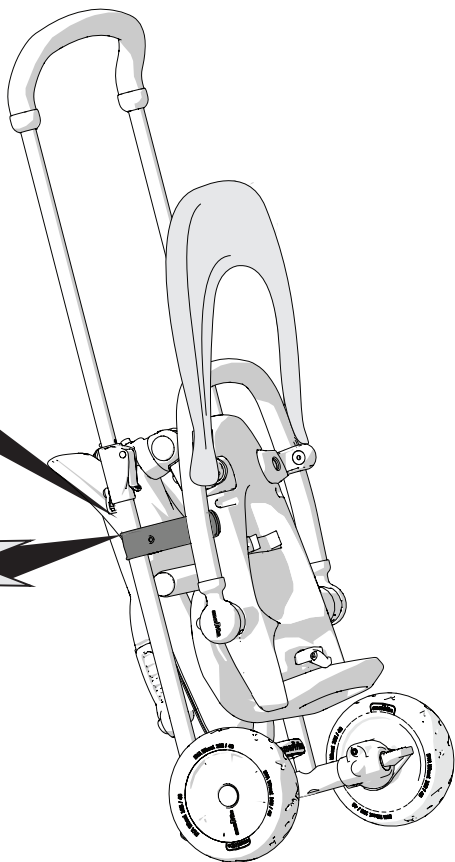

5

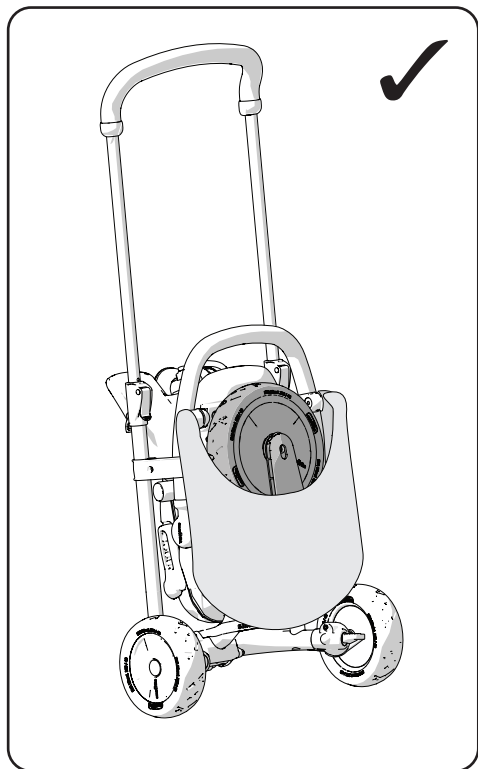
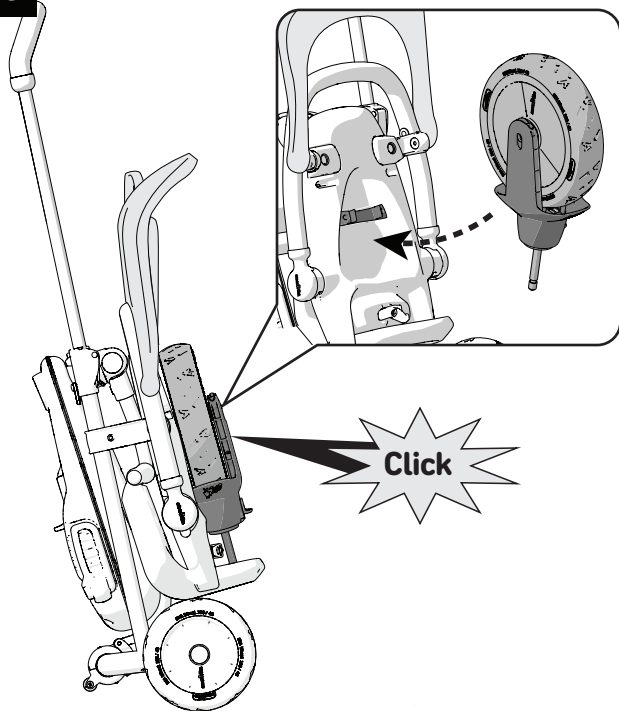

WARNING!

To avoid injury, ensure that your child is kept away when unfolding and folding this product.

¡ADVERTENCIA!

Para evitar riesgo de lesiones, asegúrese de que el niño se mantiene a cierta distancia cuando monte y pliegue este producto abajo.

For your safety carry the folded product with 2 hands.

Para transportar el producto con seguridad cuando esté plegado se debe sujetar con las dos manos como se indica.

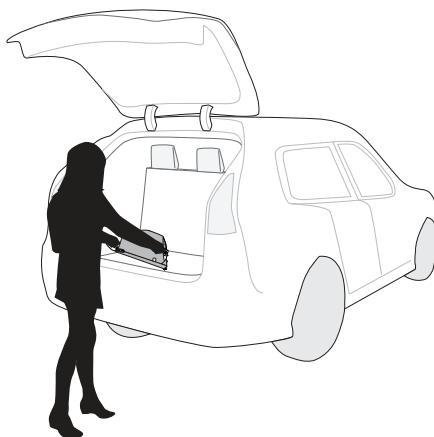
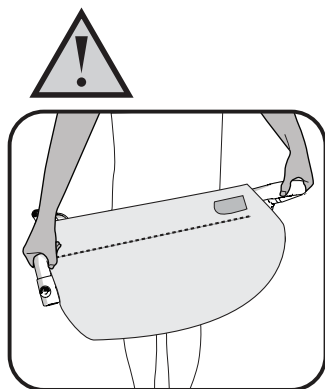

1

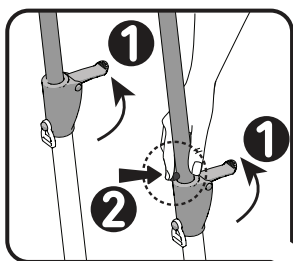

1. Open the security latches.
1. Abra las pestañas.
2. Press the pin in to release the frame.
2. Apresione la pieza de metal .
3. Push the parent handle down.
3. Empuje la barra parental hacia abajo.

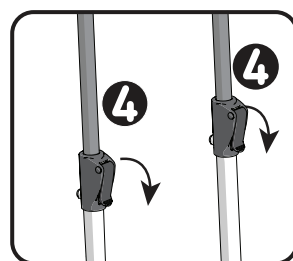
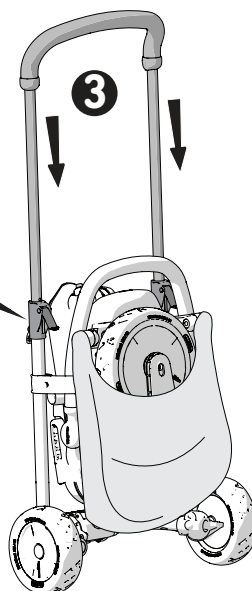

4. Close the security latches.
4. Después cierre las pestañas para bloquearlo bloquer.

2

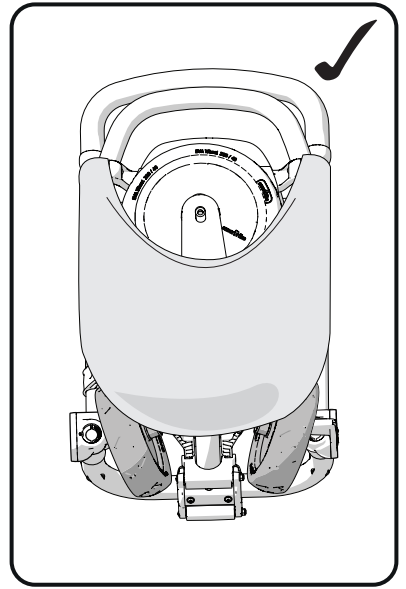
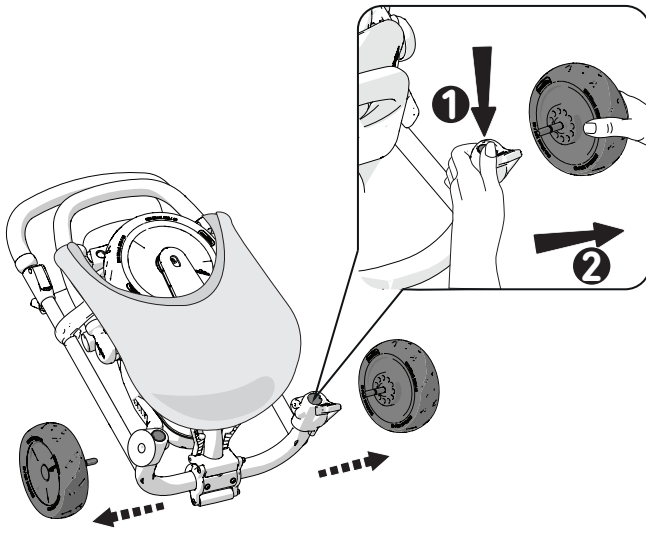

3

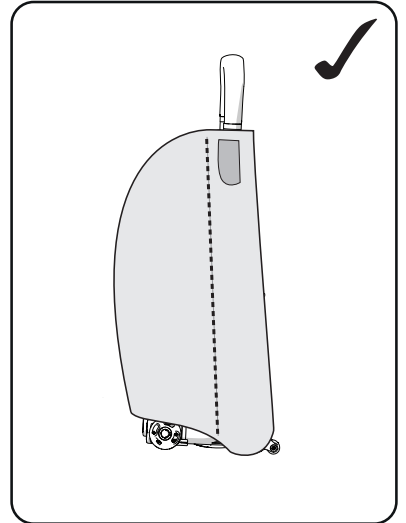
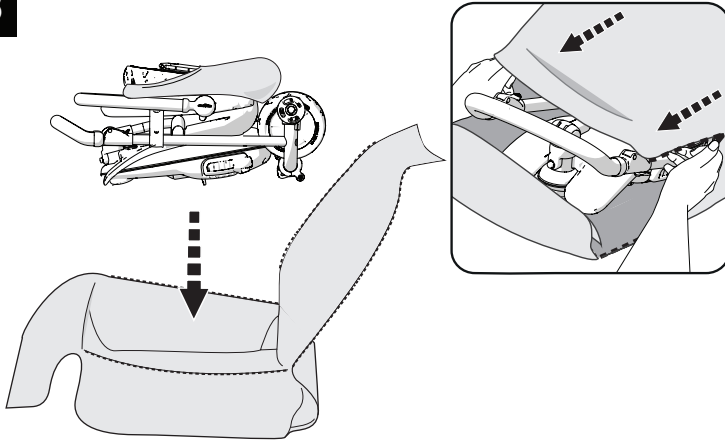

6 in 1

10m-36m

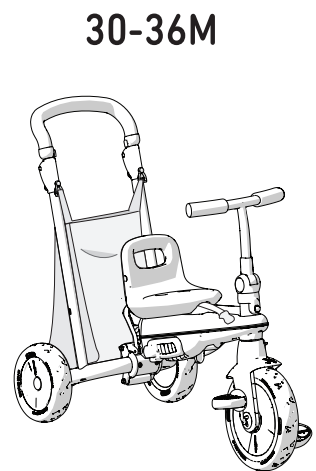
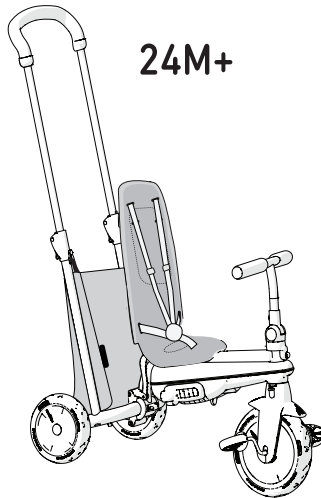
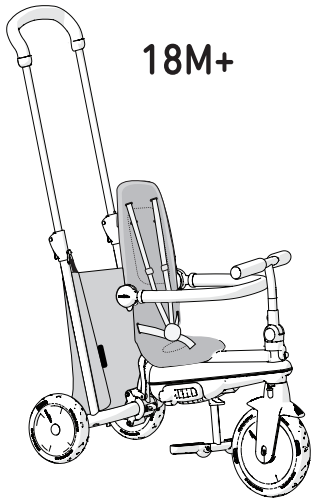
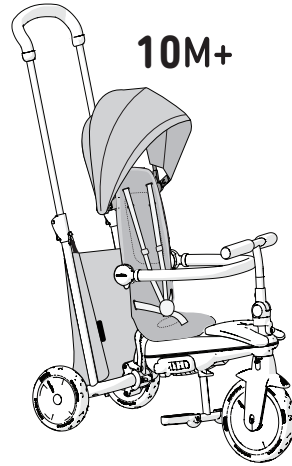
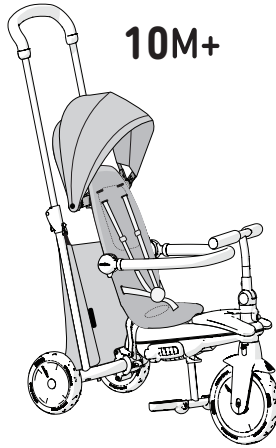
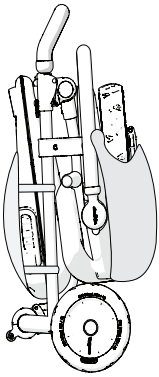



www.smarTrike.com

www.youtube.com/user/SmartTrikeOfficial

The Original
smarTrike[®]

50228057603