

EN User Manual | **Cooker**

**CGX1130ACW**

**CGX1130ACB**

**CGX1130ACM**



# Welcome to AEG! Thank you for choosing our appliance.



Get usage advice, brochures, troubleshooting, service and repair information:  
[www.aeg.com/support](http://www.aeg.com/support)

Subject to change without notice.

## CONTENTS

1. SAFETY INFORMATION.....	2
2. SAFETY INSTRUCTIONS.....	5
3. INSTALLATION.....	8
4. PRODUCT DESCRIPTION.....	11
5. BEFORE FIRST USE.....	12
6. HOB - DAILY USE.....	12
7. HOB - HINTS AND TIPS.....	14
8. HOB - CARE AND CLEANING.....	15
9. OVEN - DAILY USE.....	15
10. OVEN - CLOCK FUNCTIONS.....	18
11. OVEN - HINTS AND TIPS.....	19
12. OVEN - CARE AND CLEANING.....	19
13. TROUBLESHOOTING.....	22
14. ENERGY EFFICIENCY.....	23
15. ENVIRONMENTAL CONCERNS.....	24

## 1. ⚠ SAFETY INFORMATION

Before the installation and use of the appliance, carefully read the supplied instructions. The manufacturer is not responsible for any injuries or damage that are the result of incorrect installation or usage. Always keep the instructions in a safe and accessible location for future reference.

### 1.1 Children and vulnerable people safety

- This appliance can be used by children aged from 8 years and above and persons with reduced physical, sensory or mental capabilities or lack of experience and knowledge if they have been given supervision or instruction concerning the use of the appliance in a safe way and understand the hazards involved. Children of less than 8 years of age and persons with very extensive and complex disabilities shall

be kept away from the appliance unless continuously supervised.

- Children should be supervised to ensure that they do not play with the appliance.
- Keep all packaging away from children and dispose of it appropriately.
- **WARNING:** The appliance and its accessible parts become hot during use. Keep children and pets away from the appliance when in use and when cooling down.
- Children shall not carry out cleaning and user maintenance of the appliance without supervision.

## **1.2 General Safety**

- This appliance is for cooking purposes only.
- This appliance is designed for single household domestic use in an indoor environment.
- This appliance may be used in offices, hotel guest rooms, bed & breakfast guest rooms, farm guest houses and other similar accommodation where such use does not exceed (average) domestic usage levels.
- Only a qualified person must install this appliance and replace the cable.
- This appliance is intended for use up to an altitude of 2000 m above sea level.
- This appliance is not intended to be used on ships, boats or vessels.
- Do not install the appliance behind a decorative door in order to avoid overheating.
- Do not install the appliance on a platform.
- Do not operate the appliance by means of an external timer or separate remote-control system.
- **WARNING:** Unattended cooking on a hob with fat or oil can be dangerous and may result in fire.
- Never use water to extinguish the cooking fire. Switch off the appliance and cover flames with e.g. a fire blanket or lid.

- **CAUTION:** The cooking process has to be supervised. A short term cooking process has to be supervised continuously.
- **WARNING:** Danger of fire: Do not store items on the cooking surfaces.
- Do not use a steam cleaner to clean the appliance.
- Do not use harsh abrasive cleaners or sharp metal scrapers to clean the glass door or the glass of hinged lids of the hob since they can scratch the surface, which may result in shattering of the glass.
- Metallic objects such as knives, forks, spoons and lids should not be placed on the hob surface since they can get hot.
- Remove any spillage from the lid before opening. Let the hob surface cool down before closing the lid.
- **WARNING:** The appliance and its accessible parts become hot during use. Care should be taken to avoid touching heating elements.
- Always use oven gloves to remove or insert accessories or ovenware.
- Before maintenance, cut the power supply.
- **WARNING:** Ensure that the appliance is switched off before replacing the lamp to avoid the possibility of electric shock.
- If the mains power supply cable is damaged, it must be replaced by the manufacturer, its Authorised Service Centre or similarly qualified persons to avoid an electrical hazard.
- To remove the shelf supports first pull the front of the shelf support and then the rear end away from the side walls. Install the shelf supports in the opposite sequence.
- **WARNING:** Use only hob guards designed by the manufacturer of the cooking appliance or indicated by the manufacturer of the appliance in the instructions for use as suitable or hob guards incorporated in the appliance. The use of inappropriate guards can cause accidents.

## 2. SAFETY INSTRUCTIONS

This appliance is suitable for the following

markets:  

### 2.1 Installation

#### **WARNING!**

Only a qualified person must install this appliance.

- Remove all the packaging.
- Do not install or use a damaged appliance.
- Follow the installation instructions supplied with the appliance.
- Always take care when moving the appliance as it is heavy. Always use safety gloves and enclosed footwear.
- Do not pull the appliance by the handle.
- The kitchen cabinet and the recess must have suitable dimensions.
- Keep the minimum distance from other appliances and units.
- Install the appliance in a safe and suitable place that meets installation requirements.
- Parts of the appliance carry current. Close the appliance with furniture to prevent touching the dangerous parts.
- The sides of the appliance must stay next to appliances or units with the same height.
- Do not install the appliance adjacent to a door or under a window. This prevents hot cookware to fall from the appliance when the door or the window is opened.
- Make sure to install a stabilizing means in order to prevent tipping of the appliance. Refer to Installation chapter.

### 2.2 Electrical Connection

#### **WARNING!**

Risk of fire and electric shock.

- All electrical connections should be made by a qualified electrician.
- The appliance must be earthed.
- Make sure that the parameters on the rating plate are compatible with the

electrical ratings of the mains power supply.

- Always use a correctly installed shockproof socket.
- Do not use multi-plug adapters and extension cables.
- Do not let mains cables touch or come near the appliance door or the niche below the appliance, especially when it operates or the door is hot.
- The shock protection of live and insulated parts must be fastened in such a way that it cannot be removed without tools.
- Connect the mains plug to the mains socket only at the end of the installation. Make sure that there is access to the mains plug after the installation.
- If the mains socket is loose, do not connect the mains plug.
- Do not pull the mains cable to disconnect the appliance. Always pull the mains plug.
- Use only correct isolation devices: line protecting cut-outs, fuses (screw type fuses removed from the holder), earth leakage trips and contactors.
- The electrical installation must have an isolation device which lets you disconnect the appliance from the mains at all poles. The isolation device must have a contact opening width of minimum 3 mm.
- Fully close the appliance door before you connect the mains plug to the mains socket.

### 2.3 Gas connection

- All gas connections must be made by a qualified person.
- Before installation, make sure that the local distribution conditions (nature of the gas and gas pressure) and the adjustment of the appliance are compatible.
- Make sure that there is air circulation around the appliance.
- The information about the gas supply is on the rating plate.
- This appliance is not connected to a device which evacuates the products of combustion. Make sure to connect the appliance in accordance with current

installation regulations. Follow the requirements for adequate ventilation.

## 2.4 Use

### **WARNING!**

Risk of injury and burns.  
Risk of electrical shock.

### **CAUTION!**

The use of a gas cooking appliance results in the production of heat, moisture and products of combustion in the room in which it is installed. Ensure that the kitchen is well ventilated especially when the appliance is in use.

Prolonged intensive use of the appliance may require additional ventilation, for example the increasing of mechanical ventilation where present, additional ventilation to safely remove the products of combustion to outside (external) air whilst also providing room air changes with additional ventilation. Consult a qualified person before installation of the additional ventilation.

- Do not change the specification of this appliance.
- Make sure that the ventilation openings are not blocked.
- Do not let the appliance stay unattended during operation.
- Deactivate the appliance after each use.
- Be careful when you open the appliance door while the appliance is in operation. Hot air can release.
- Do not operate the appliance with wet hands or when it has contact with water.
- Do not use the appliance as a work surface or as a storage surface.
- Do not use aluminum foil or other materials between the cooking surface and the cookware, unless otherwise specified by the manufacturer of this appliance.
- Use only accessories recommended for this appliance by the manufacturer.
- Always use glass and jars approved for preserving purposes.

### **WARNING!**

Risk of fire and explosion.

- Fats and oil when heated can release flammable vapours. Keep flames or heated objects away from fats and oils when you cook with them.
- The vapours that very hot oil releases can cause spontaneous combustion.
- Used oil, that can contain food remnants, can cause fire at a lower temperature than oil used for the first time.
- Do not put flammable products or items that are wet with flammable products in, near or on the appliance.
- Do not let sparks or open flames to come in contact with the appliance when you open the door.
- Open the appliance door carefully. The use of ingredients with alcohol can cause a mixture of alcohol and air.

### **WARNING!**

Risk of damage to the appliance.

- To prevent damage or discoloration to the enamel:
  - do not put ovenware or other objects in the appliance directly on the bottom.
  - do not put aluminium foil directly on the bottom of cavity.
  - do not put water directly into the hot appliance.
  - do not keep moist dishes and food in the appliance after you finish the cooking.
  - be careful when you remove or install the accessories.
- Discoloration of the enamel or stainless steel has no effect on the performance of the appliance.
- Use a deep pan for moist cakes. Fruit juices cause stains that can be permanent.
- Do not keep hot cookware on the control panel.
- Do not let cookware boil dry.
- Be careful not to let objects or cookware fall on the appliance. The surface can be damaged.
- Never leave a burner on with empty cookware or without cookware.

- Cookware made of cast iron, aluminium or with a damaged bottom can cause scratches. Always lift these objects up when you have to move them on the cooking surface.
- Provide good ventilation in the room where the appliance is installed.
- Use only stable cookware with the correct shape and diameter larger than the dimensions of the burners.
- Make sure the flame does not go out when you quickly turn the knob from the maximum to the minimum position.
- Do not install a flame diffuser on the burner.

## 2.5 Care and Cleaning

### **WARNING!**

Risk of injury, fire, or damage to the appliance.

- Before maintenance, deactivate the appliance. Disconnect the mains plug from the mains socket.
- Make sure the appliance is cold. There is the risk that the glass panels can break.
- Replace immediately the door glass panels when they are damaged. Contact the Authorised Service Centre.
- Be careful when you remove the door from the appliance. The door is heavy!
- Fat and food remaining in the appliance can cause fire.
- Clean regularly the appliance to prevent the deterioration of the surface material.
- Make sure the cavity and the door are wiped dry after each use. Steam produced during the operation of the appliance condensates on cavity walls and can cause corrosion. To decrease the condensation operate the appliance for 10 minutes before cooking.
- Clean the appliance with a moist soft cloth. Use only neutral detergents. Do not use abrasive products, abrasive cleaning pads, solvents or metal objects.
- If you use an oven spray, follow the safety instructions on the packaging.
- Do not clean the catalytic enamel (if applicable) with any kind of detergent.

- Do not clean the burners in the dishwasher.

## 2.6 Lid

- Do not change the specification of the lid.
- Clean the lid regularly.
- Do not open the lid, when there are spills on the surface.
- Before you close the lid turn all burners off.
- Do not close the lid until the hob and oven are completely cold.
- Glass lid can shatter, when heated (if applicable).



## 2.7 Internal lighting

### **WARNING!**

Risk of electric shock.

- Concerning the lamp(s) inside this product and spare part lamps sold separately: These lamps are intended to withstand extreme physical conditions in household appliances, such as temperature, vibration, humidity, or are intended to signal information about the operational status of the appliance. They are not intended to be used in other applications and are not suitable for household room illumination.
- This product contains a light source of energy efficiency class G.
- Use only lamps with the same specifications.

## 2.8 Service

- To repair the appliance contact the Authorised Service Centre.
- Use original spare parts only.

## 2.9 Disposal

### **WARNING!**

Risk of injury or suffocation.

- Contact your municipal authority for information on how to dispose of the appliance.
- Disconnect the appliance from the mains supply.

- Cut off the mains electrical cable close to the appliance and dispose of it.
- Flat the external gas pipes.

### 3. INSTALLATION

#### **⚠ WARNING!**

Refer to Safety chapters.

#### 3.1 Technical data

##### Dimensions

Height	899 - 917 mm
Width	550 mm
Depth	600 mm

#### 3.2 Location of the appliance

You can install your freestanding appliance with cabinets on one or two sides and in the corner.

For the minimal distances of fitting check the table.

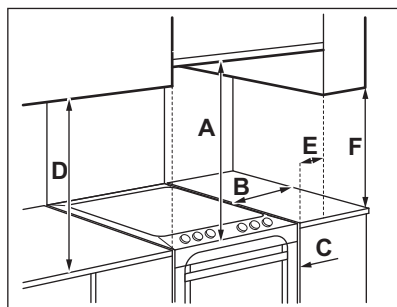

##### Minimum distances

Dimension	mm
A	650
B	450
C	2
D	400
E	150

Dimension	mm
F	less than 400

#### 3.3 Levelling of the appliance

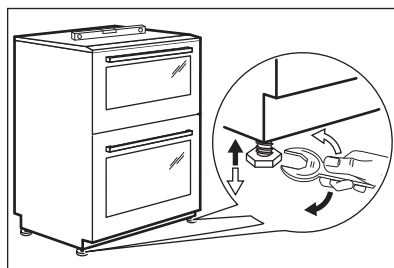

Use small feet on the bottom of appliance to set the appliance top surface level with other surfaces.

#### 3.4 The stability chain

#### **⚠ CAUTION!**

Install the stability chain to prevent the appliance from tilting. The stability chain only works when the appliance is put in a correct area.

1. Measure down 180 mm from the appliance top surface, then measure right 30 mm.
2. Mark the position of the wall and this gives anchor point for the stability chain.



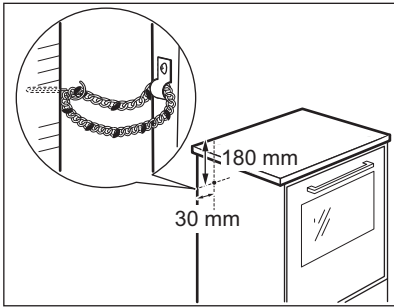

### 3.5 Other technical data

#### **⚠ WARNING!**

These instructions are only valid in the countries whose symbols appear on this booklet's cover.

Gas category:	I2H
Gas supply:	G20 (2H) 20 mbar
Voltage:	220-240 V
Frequency:	50 Hz

### 3.6 Gas burners

BURNER	NORMAL POWER kW	Natural Gas	
		INJECTOR MARK 1/100 mm	Btu/h
Auxiliary	0.95	70	3242
Semi-rapid	1.9	96	6483
Rapid	2.8	119	10236
Semi-rapid	1.9	96	6483
Top Oven	1.7	95	5804
Main Oven	1.7	95	5804

### 3.7 Gas Connection

Use a flexible pipe in compliance with the regulation in force. Make sure they do not come in touch with mobile parts and are not squeezed.

#### **⚠ WARNING!**

Only a qualified and competent person can do the gas installation. Before you connect to gas, disconnect the appliance from the electricity supply or switch off the fuse in the fuse box. Close the primary valve of the gas supply.



Supply piping should not be less than R3/8. Connection is made to the Rc 1/2 (1/2 " B.S.P.) female threaded. The entry pipe is located just below the hob level on the rear left hand side of the appliance.

The gas supply ramp is on the rear side of the appliance.

#### **⚠ WARNING!**

Only liquid sealants can be used when the inlet gas pipe is fitted i.e.: do not use the P.T.F.E. sealant tape.

When the installation is complete, carry out a gas tightness test and make sure that the seal of each pipe fitting does not leak.



Use flexible tubing, which comply with the BS.669 current edition.

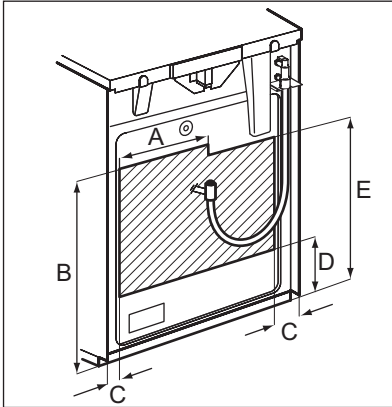

**⚠ WARNING!**

The gas bayonet connector must be in the marked area.

Dimension	mm
A	250
B	680
C	50
D	250
E	580

### 3.8 Pressure test

Use a semi rapid injector for the pressure test.

1. Connect a pressure gauge to the semi rapid injector.
2. Check the supply pressure by fully turning on the semi rapid burner, and any other burner and lighting them. For natural gas, the pressure must be 20 mbar.
3. Turn off the taps and disconnect the pressure gauge.
4. Make sure that all burners work properly.

### 3.9 Checking the hob burners

1. Lift the lid.

2. Put on the burner crowns and caps. Make sure that they are correctly seated.
3. Put on the pan supports.
4. Light one of the hob burners.  
To light the hob burner refer to the "Ignition of the hob burners".  
Check if the flame is regular.  
Check each of the burners.
5. Turn the knob for the hob to the off position.

### 3.10 Checking the oven burners

1. Put in the deep pan and the trivet.
2. Light the oven burner.  
To light the oven burner refer to the "Ignition of the oven burners".  
Check if the flame is regular.
3. Turn the knob to the off position.

### 3.11 Checking the Lid Safety Device

1. Lift the lid.
2. Light one of the hob burners.  
To light the hob burner refer to the "Ignition of the hob burners".
3. Close the lid. There should be no gas supply to the hob burners. The burner goes out.
4. Turn the knob to the off position and lift the lid. The gas supply should be restored to the hob burners, when you turn the knob on.

### 3.12 Electrical installation

**⚠ WARNING!**

The manufacturer is not responsible if you do not follow the safety precautions from Safety chapters.

This appliance is supplied with a main plug and a main cable.



The spark generator is active all the time if the phases are not connected correctly.

**⚠ WARNING!**

The power cable must not touch the part of the appliance shaded in the illustration.

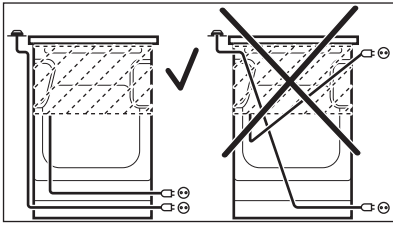

## 4. PRODUCT DESCRIPTION

### 4.1 General overview

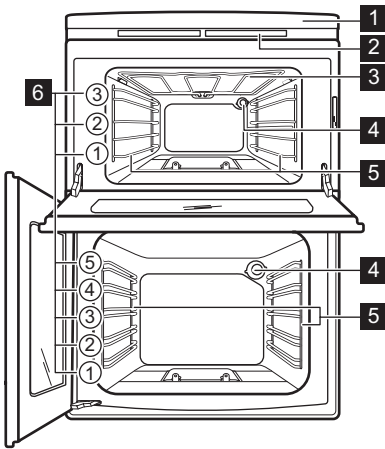

- 1 Control panel and hob
- 2 Air vents for the cooling fan
- 3 Grill
- 4 Lamp
- 5 Shelf support, removable
- 6 Shelf positions

### 4.2 Hob overview

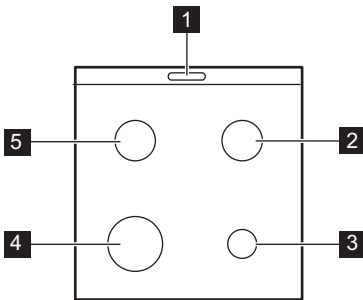

- 1 Steam outlet - number and position depend on the model
- 2 Semi-rapid burner

- 3 Auxiliary burner
- 4 Power rapid burner
- 5 Semi-rapid burner

### 4.3 Cooker control panel

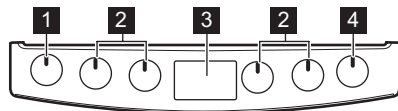

- 1 Knob for the top oven
- 2 Knobs for the hob
- 3 Display
- 4 Knob for the main oven

## 4.4 Accessories

- **Wire shelf**  
For cookware, cake tins, roasts.
- **Grill- / Roasting pan**  
To bake and roast or as pan to collect fat.
- **Trivet**

For roasting and grilling.



Use the trivet only with the Grill- / roasting pan.

## 5. BEFORE FIRST USE

### **WARNING!**

Refer to Safety chapters.

### 5.1 Initial Cleaning

Remove all accessories and removable shelf supports from the appliance.



Refer to "Care and cleaning" chapter.

Clean the appliance and the accessories before first use.

Put the accessories and the removable shelf supports back to their initial position.

### 5.2 Setting and changing the time

You must set the time before you operate the oven.

When you connect the appliance to the electrical supply or after a power cut, flashes.

Press the or to set the correct time.

After approximately 5 seconds, the flashing stops and the display shows the time of day.

To change the time, press again and again until starts to flash.



You cannot change the time of day if any of the functions operates.

### 5.3 Preheating

Preheat the empty appliance before first use.



Preheat the two ovens. Heat up one oven at a time.

1. Set the maximum temperature.
2. Let the appliance operate for 1 hour.
3. Set the function .
4. Let the appliance operate for 15 minutes. Accessories can become hotter than usual. The appliance can emit an odour and smoke. This is normal. Make sure that the airflow is sufficient.

## 6. HOB - DAILY USE

### **WARNING!**

Refer to Safety chapters.

### 6.1 Ignition of the hob burners



Always light the burner before putting on the cookware.

### **WARNING!**

Be very careful when you use open fire in the kitchen environment. The manufacturer declines any responsibility in case of the flame misuse.

1. Turn the knob for the hob to the position and push it down. When you push the knob, the spark generator activates automatically.

- Keep the knob for the hob pushed for equal or less than 10 seconds to let the thermocouple warm up. If not, the gas supply is interrupted.
- Adjust the flame after it is regular.

**⚠ WARNING!**

Do not keep the knob pushed for more than 10 seconds. If the burner does not light after 10 seconds, release the knob, turn it into the off position and try to light the burner again after minimum 1 minute.



If after some tries the burner does not light, check if the crown and its cap are in the correct position.

## 6.2 Burner overview

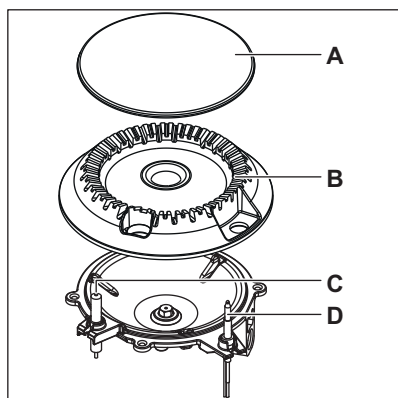

## 6.3 Replacing burner parts

- Put carefully the burner crown on the burner body. Let the crown fall freely onto the body. Do not use force.  
Make sure that the hole in the crown is above the ignition candle.  
Make sure that the location pegs are in the slots in the burner body.  
Make sure that you can move the crown a small distance from side to side.
- Put the burner cap centrally on top of the crown.  
Make sure that the cap is correctly installed, with the enamel side up and you



It is not possible to use the hob without electricity.



If the burner accidentally goes out, turn the knob to the off position and try to light the burner again after minimum 1 minute.



The spark generator can start automatically when you switch on the mains, after installation or a power cut. It is normal.

- A. Burner cap
- B. Burner crown
- C. Ignition candle
- D. Thermocouple

can move the cap from side to side and front to back.

- Light the burner.  
If the burner does not ignite, adjust the crown and cap again.

## 6.4 Turning the burner off

To put the flame out, turn the knob to the off position **0**.

**⚠ WARNING!**

Always turn the flame down or switch it off before you remove the pans from the burner.

**⚠ WARNING!**

Always use the knob for the hob to switch off a burner. Do not use the lid as a cut-off device.

### 6.5 Lid Safety Device

Lid has safety device, which cuts off the gas supply for the hob. Closing the lid activates the safety device.

## 7. HOB - HINTS AND TIPS

**⚠ WARNING!**

Refer to Safety chapters.

### 7.1 Cookware

- **recommended:** aluminium, copper
- **not recommended:** stainless steel, cast iron, glass

**⚠ WARNING!**

Do not put the same pan on two burners.

**⚠ WARNING!**

Do not put unstable or damaged pots on the burner to prevent spills and injuries.

**⚠ CAUTION!**

Make sure that pot handles are not above the front edge of the cooktop.

**⚠ CAUTION!**

Make sure that the pots are placed centrally on the burner in order to get the maximum stability and a lower gas consumption.

**⚠ WARNING!**

Do not use vessels that have rim based or convex-based shaped bottom on the hotplate as there is a high risk of overturn.

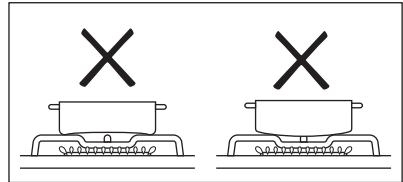

### 7.2 Diameters of cookware

**⚠ WARNING!**

Use cookware with diameters applicable to the size of burners.

Burner	Diameter of cookware (mm)
Rapid	180 - 240 / 260 <sup>1)</sup>
Semi-rapid	120 - 220 / 240 <sup>1)</sup>
Auxiliary	80 - 160

<sup>1)</sup> When a single pot is used on the hob

## 8. HOB - CARE AND CLEANING

### **WARNING!**

Refer to Safety chapters.

### 8.1 General information

- Clean the hob after each use.
- Always use cookware with a clean base.
- Scratches or dark stains on the surface have no effect on how the hob operates.
- Use a special cleaning agent suitable for the surface of the hob.

### 8.2 Pan supports

1. Remove the pan supports to easily clean the hob.



Be very careful when you replace the pan supports to prevent the hob top from damage.

2. The enamel coating occasionally can have rough edges, so be careful when you wash the pan supports by hand and dry them. If necessary, remove stubborn stains with a paste cleaner.

3. After you clean the pan supports, make sure that they are in correct positions.
4. For the burner to operate correctly, make sure that the arms of the pan supports are aligned with the center of the burner.

### 8.3 Cleaning the hob

- **Remove immediately:** melted plastic, plastic foil, salt, sugar and food with sugar, otherwise, the dirt can cause damage to the hob. Take care to avoid burns.
- **Remove when the hob is sufficiently cool:** limescale rings, water rings, fat stains, shiny metallic discoloration. Clean the hob with a moist cloth and a non-abrasive detergent. After cleaning, wipe the hob dry with a soft cloth.

### 8.4 Cleaning the spark plug



This feature is obtained through a ceramic ignition candle with a metal electrode. Keep these components well clean to prevent difficult lighting and check that the burner crown holes are not obstructed.

## 9. OVEN - DAILY USE

### **WARNING!**

Refer to Safety chapters.

### 9.1 Top Oven Functions

Oven function		Application
0	Off position	The oven is off.
	Full Grill	To grill flat food and to toast bread. When the function is active, the lamp turns on.
1 - 8 1)	Heat settings	Heat settings for Conventional Cooking.
	Ignition	To activate the top oven.

1) 1 - 145 °C, 2 - 165 °C, 3 - 180 °C, 4 - 200 °C, 5 - 225 °C, 6 - 255 °C, 7 - 280 °C, 8 - 295 °C

## 9.2 Main Oven Functions

Oven function		Application
0	Off position	The appliance is off.
↓°C	Minimum temperature	To set the minimum temperature.
1 - 8 1)	Heat settings	Heat settings for Conventional Cooking.
★	Ignition	To activate the main oven.

1) min - 135 °C, 1 - 155°C, 2 - 170°C, 3 -185°C, 4 - 210°C, 5 - 235°C, 6 - 250°C, 7 - 260°C, 8 - 265 °C

## 9.3 Igniting the oven burners

### ⚠ CAUTION!

When the oven is active, the lid has to be opened to avoid over-heating. Keep the oven door open when you ignite the burner.



### Oven safety device:

The oven burners have a thermocouple. It stops the gas flow, if the flame goes out.



You cannot operate the top oven burner, when the grill is active.

1. Open the oven door.
2. Push the knob for the main oven and turn it counterclockwise to ★ to ignite the main oven burner.
  - Push the knob for the top oven and turn it counterclockwise to ★ to ignite the top oven burner.
3. Keep the knob pushed for equal or less than 15 seconds to let the thermocouple warm up. If not, the gas flow is interrupted.
4. After ignition release the knob, close the oven door and turn the knob to set the necessary heat setting.

### ⚠ WARNING!

Do not push the knob for more than 15 seconds. If the oven burner does not light after 15 seconds, release the knob, turn it back to off position and try to light the oven burner again after minimum 1 minute.

### ⚠ CAUTION!

In the absence of electricity you can ignite the oven burner without an electrical device. In this case open the oven door, put the flame near the hole in the bottom of the oven cavity, turn the knob to the spark position and push it down. Keep the knob for the oven functions pushed for equal or less than 15 seconds to let the thermocouple warm up.



If the oven burner accidentally goes out, turn the knob for the oven functions to the off position and try to light the burner again after minimum 1 minute. Check if the burner holes are not blocked.

## 9.4 Turning off the oven burners

To put out the flame, turn the knob to the off position.

## 9.5 Using the grill

1. Turn the knob for the oven functions clockwise to ☐



2. Adjust the deep pan runner position to fit in different portions of food.  
Refer to Grilling in "Hints and Tips" chapter.

## 9.6 Cooling fan

When the appliance operates, the cooling fan turns on automatically to keep the surfaces of the appliance cool. If you turn off the appliance, the cooling fan can continue to operate until the appliance cools down.



If there is a defect in the cooling fan, contact the Authorised Service Centre.

## 9.7 Inserting the oven accessories

### Deep pan:

Do not use the deep pan on the first shelf position in the main oven.

Push the deep pan between the guide bars of the shelf support.

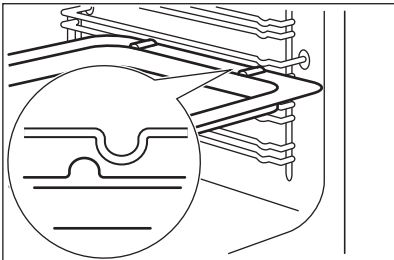

### Wire shelf:

Push the shelf between the guide bars of the shelf support.

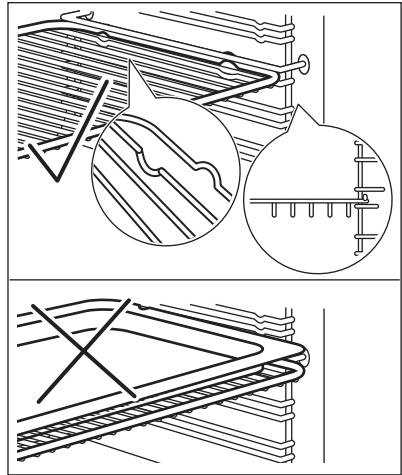

- All accessories have small indentations at the top of the right and left side to increase safety. The indentations are also anti-tip devices.
- The high rim around the shelf is a device which prevents cookware from slipping.

## 9.8 Trivet and Grill- / Roasting pan

**Step 1** Put the trivet into a deep pan.

**Step 2** Put the deep pan on the recommended shelf position.

**Roasting larger pieces of meat or poultry on one shelf position.**

**Grilling and toasting thin pieces of food in large quantities.**

Make sure the supports of the wire shelf point up.

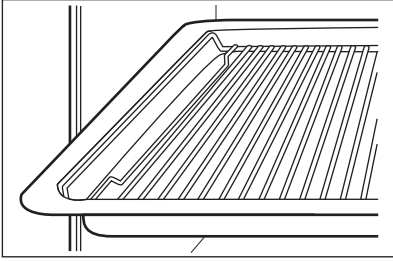

Make sure the supports of the wire shelf point down.

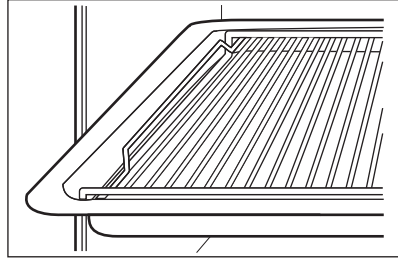

## 10. OVEN - CLOCK FUNCTIONS

### 10.1 Display

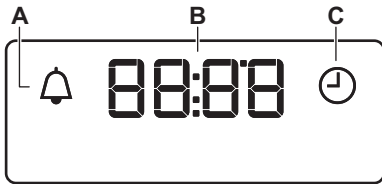

- A. Minute minder indicator
- B. Time display
- C. Time of day indicator

### 10.2 Buttons

Button	Function	Description
—	MINUS	To set the time.
🕒	CLOCK	To set a clock function.
+	PLUS	To set the time.

### 10.3 Setting the MINUTE MINDER

1. Press 🕒 again and again until 🔔 starts to flash.
2. Press + or — to set the necessary time. The Minute Minder starts automatically after 5 seconds.
3. When the set time ends, an acoustic signal sounds. Press any button to stop the acoustic signal.
4. Turn the knob for the oven functions to the off position.

### 10.4 Cancelling the clock functions

1. Press the 🕒 again and again until the necessary function indicator starts to flash.
2. Press and hold —. The clock function goes out after some seconds.

## 11. OVEN - HINTS AND TIPS

### **WARNING!**

Refer to Safety chapters.



The temperature and baking times in the tables are guidelines only. They depend on the recipes and the quality and quantity of the ingredients used.



Do not put wire shelves, trays or pans on the first grid position. The trays and pans cover the oven burner and block closing the oven door.



### **CAUTION!**

Place the food in the centre of the oven shelf to avoid food spillage. It can block the burner holes.

### 11.1 Information for test institutes

#### Main oven

Food	Preheating time (min)	Heat setting	Time (min)	Shelf position	Accessories
Small cake	15	2	20 - 30	4	Grill-/Roasting pan
Fatless sponge cake	15	2	25 - 35	3	1 tin (Ø 26 cm) on wire shelf
Apple pie	15	3	80 - 100	3	2 tins (Ø 20 cm) on wire shelf
Pastry stripes / short bread	15	1	15 - 20	4	Patisserie tray

#### Top oven - grill

Food	Preheating time (min)	Time (min)	Shelf position	Accessories
Beef burgers	10	15 - 20 first side 5 - 10 second side	2	Trivet with Grill-/Roasting pan
Toast	10	2 - 3	2	Trivet with Grill-/Roasting pan

## 12. OVEN - CARE AND CLEANING

### **WARNING!**

Refer to Safety chapters.

### 12.1 Notes on cleaning

#### Cleaning Agents

- Clean the front of the appliance only with a microfibre cloth with warm water and a

mild detergent. Clean and check the door gasket around the frame of the cavity.

- Use a cleaning solution to clean metal surfaces.
- Clean stains with a mild detergent. Do not apply it on the catalytic surfaces.

#### Everyday Use

- Clean the cavity after each use. Fat accumulation or other residue may cause fire.
- Do not store food in the appliance for longer than 20 minutes. Dry the cavity only with a microfibre cloth after each use.

### Accessories

- Clean all accessories after each use and let them dry. Use only a microfibre cloth with warm water and a mild detergent. Do not clean the accessories in a dishwasher.
- Do not clean the non-stick accessories using abrasive cleaner or sharp-edged objects.

## 12.2 Catalytic cleaning

### ⚠ CAUTION!

Do not clean the catalytic surface with oven sprays, soap or other cleaning agents. It will damage the catalytic surface.

### ⚠ CAUTION!

Always turn the oven light on while using the catalytic cleaning (if applicable).

### ⚠ WARNING!

Keep children away when you clean the oven at a high temperature. The oven surface becomes very hot and there is a risk of burns.

### i

Spots or discolouration of the catalytic surface have no effect on catalytic properties.

### i

Before activating the catalytic cleaning remove all the accessories from the oven.

The walls with catalytic coating are self-cleaning. They absorb fat which collects on the walls while the appliance operates.

To support the self-cleaning procedure, heat the empty oven on a regular basis.

The oven cavities must be cleaned separately.

## 12.3 Cleaning the top oven

1. Clean the oven floor with warm water and washing-up liquid, then dry it.
2. Set the maximum temperature and let the oven operate for 1 hour.
3. When the appliance is cool, clean it with a soft and moist sponge.

## 12.4 Cleaning the main oven

1. Clean the oven floor with warm water and washing-up liquid, then dry it.
2. Set the maximum temperature and let the oven operate for 1 hour.
3. When the appliance is cool, clean it with a soft and moist sponge.

## 12.5 Removing the shelf supports

To clean the oven, remove the shelf supports.

1. Pull the front of the shelf support away from the side wall.

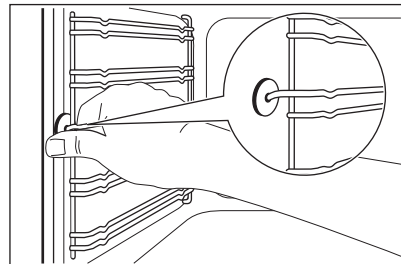

2. Pull the rear end of the shelf support away from the side wall and remove it.

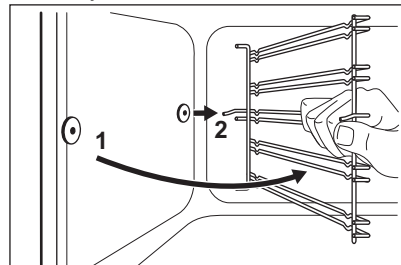

Install the shelf supports in the opposite sequence.

**⚠ CAUTION!**

Make sure that the longer fixing wire is in the front. The ends of the two wires must point to the rear. Incorrect installation can cause damage to the enamel.

## 12.6 Removing and cleaning the door glasses - top oven

**i**

The door glass in your product can be different in type and shape from the examples you see in the image. The number of glasses can also be different.

1. Open the door.
2. Hold the door trim on the top edge of the door at the two sides and push inwards to release the clip seal.

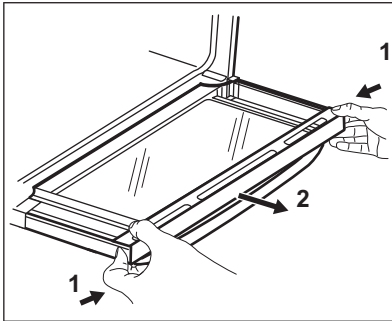

3. Pull the door trim to the front to remove it.
4. Remove the glass panels. To install the panels, do the same steps in reverse.

## 12.7 Removing and cleaning the door glasses - main oven

**i**

The door glass in your product can be different in type and shape from the example you see in the image. The number of glasses can also be different.

1. Push the door trim at one side to remove it.

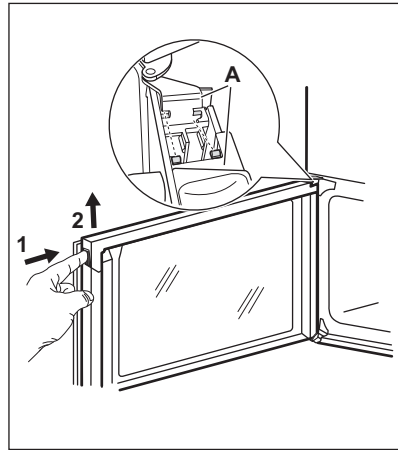

2. Pull up the trim.
3. Remove the glass panels.

**i**

To replace the glass panels, do the same steps in reverse. Before you lower the trim, attach the A trim part to the door. Refer to the image.

## 12.8 Replacing the lamp

**⚠ WARNING!**

Risk of electric shock.  
The lamp can be hot.

1. Turn off the oven. Wait until the oven is cold.
2. Disconnect the oven from the mains.
3. Put a cloth on the bottom of the cavity.

### The back lamp

**i**

The lamp glass cover is at the back of the cavity.

1. Turn the lamp glass cover counterclockwise to remove it.
2. Clean the glass cover.
3. Replace the oven lamp with a suitable 300 °C heat-resistant oven lamp. Use the same oven lamp type.
4. Install the glass cover.

## 13. TROUBLESHOOTING

### **WARNING!**

Refer to Safety chapters.

### 13.1 What to do if...

Problem	Possible cause	Remedy
You cannot activate the appliance.	The appliance is not connected to an electrical supply or it is connected incorrectly.	Check if the appliance is correctly connected to the electrical supply.
You cannot activate the appliance.	The fuse is blown.	Make sure that the fuse is the cause of the malfunction. If the fuse is blown again and again, contact a qualified electrician.
The burners do not work.	There is no gas supply.	Check the gas connection.
There is no spark when you try to activate the spark generator.	Burner cap and crown are placed incorrectly.	Place the burner cap and crown correctly.
The flame extinguishes immediately after ignition.	Thermocouple is not heated up sufficiently.	After lighting the flame, keep the knob pushed for equal or less than 10 seconds.
The flame ring is uneven.	Burner crown is blocked with food residues.	Make sure that the injector is not blocked and the burner crown is clean.
The oven does not heat up.	The oven is deactivated.	Activate the oven.
The oven does not heat up.	The clock is not set.	Set the clock.
The oven does not heat up.	The necessary settings are not set.	Make sure that the settings are correct.
The lamp does not operate.	The lamp is defective.	Replace the lamp.
The display shows "12.00".	There was a power cut.	Reset the clock.
Steam and condensation settle on the food and in the cavity of the oven.	You left the dish in the oven for too long.	Do not leave the dishes in the oven for longer than 15 - 20 minutes after the cooking process ends.

### 13.2 Service data

If you cannot find a solution to the problem yourself, contact your dealer or an Authorised Service Centre.

The necessary data for the service centre is on the rating plate. The rating plate is on the front frame of the appliance cavity. Do not remove the rating plate from the appliance cavity.

#### **We recommend that you write the data here:**

Model (MOD.)	.....
Product number (PNC)	.....
Serial number (S.N.)	.....

## 14. ENERGY EFFICIENCY

### 14.1 Product Information according to EU and UK Ecodesign Regulations for Hob

Model identification	CGX1130ACW CGX1130ACB CGX1130ACM	
Type of hob	Hob inside Freestanding Cooker	
Number of gas burners	4	
Energy efficiency per gas burner (EE gas burner)	Left Front - Rapid	55.0 %
	Left rear - Semi Rapid	55.6 %
	Right front - Auxiliary	not applicable
	Right rear- Semi Rapid	55.6 %
Energy efficiency for the gas hob (EE gas hob)	55.4 %	
EN 30-2-1: Domestic cooking appliances burning gas - Part 2-1 : Rational use of energy - General.		

#### 14.2 Hob - Energy saving

You can save energy during everyday cooking if you follow the hints below.

- When you heat up water, use only the amount you need.
- If it is possible, always put the lids on the cookware.
- Before you use the burners and pan support make sure they are assembled correctly.
- The cookware bottom should have the correct diameters for the burner size.
- Put the cookware directly over the burner and in the centre of it.
- When the liquid starts to boil, turn down the flame to barely simmer the liquid.
- If it is possible, use a pressure cooker. Refer to its user manual.

### 14.3 Product Information Sheet and Product Information according to EU and UK Energy Labelling and Ecodesign Regulations for Oven

Supplier's name	AEG
Model identification	CGX1130ACW 948905186 CGX1130ACB 948905187 CGX1130ACM 948905188
Energy Efficiency Index	Top oven: 95.1 Main oven: 90.0
Energy efficiency class	Top oven: A Main oven: A

Energy consumption with a standard load, conventional mode	Top oven: 1.35 kWh/cycle 4.86 MJ/cycle Main oven: 1.80 kWh/cycle 6.46 MJ/cycle
Number of cavities	2
Heat source	Gas
Volume	Top oven: 36 l Main oven: 83 l
Type of oven	Oven inside Freestanding Cooker
Mass	CGX1130ACW 56.6 kg
	CGX1130ACB 57.0 kg
	CGX1130ACM 57.0 kg

EN 15181 Measuring method of the energy consumption of gas fired ovens.

#### 14.4 Oven - Energy saving

Following tips below will help you save energy when using your appliance.

Make sure that the appliance door is closed when the appliance operates. Do not open the appliance door too often during cooking. Keep the door gasket clean and make sure it is well fixed in its position.

Use metal cookware and dark, non-reflective tins and containers to improve energy saving.

Do not preheat the appliance before cooking unless specifically recommended.

Keep breaks between baking as short as possible when you prepare a few dishes at one time.

#### Residual heat

When the cooking duration is longer than 30 min, reduce the appliance temperature to minimum 3 - 10 min before the end of cooking. The residual heat inside the appliance will continue to cook.

Use the residual heat to keep the food warm or warm up other dishes.

#### Keep food warm

Choose the lowest possible temperature setting to use residual heat and keep the food warm.

#### 14.5 Product Information for power consumption and maximum time to reach applicable low power mode

Power consumption in standby	0.8 W
Maximum time needed for the equipment to automatically reach the applicable low power mode	20 min

### 15. ENVIRONMENTAL CONCERNS

Recycle materials with the symbol . Put the packaging in relevant containers to recycle it.

Help protect the environment and human health by recycling waste of electrical and electronic appliances. Do not dispose of



appliances marked with the symbol  with the household waste. Return the product to your local recycling facility or contact your municipal office.

Electrolux Appliances AB - Contact Address:  
Al. Powstancow Slaskich 26, 30-570 Krakow,  
Poland





**aeg.com**

867364328-A-362024



UK  
CA CE