

Series 4, French door bottom freezer, multi door, 183 x 90.5 cm, Inox-easyclean KFN96VPEAG



This multi door refrigerator with VitaFresh Box: cools very efficiently - thanks to the cooling compartment, your fruits and vegetables stay fresh longer.

- **NoFrost:** you'll never have to defrost your fridge-freezer again.
- **XXL capacity:** extra space for your food when you need it.
- **Big Box drawer:** for stacking storage containers or for large frozen food items.
- **Super Cooling function:** cools new food placed inside faster, thus protecting already cooled food.
- LED lights bring a completely new lighting concept to fridges

Technical Data

Energy Efficiency Class: E

Average annual energy consumption in kilowatt hour per year (kWh/a): 333 kWh/a

Sum of volume of frozen compartments: 200 l

Sum of volume of chill compartments: 405 l

Airborne acoustical noise emissions : 38 dB(A) re 1 pW

Airborne acoustical noise emission class: C

Construction type: Free-standing

Number of compressors: 1

Number of independent cooling systems: 1

Width of the appliance: 905 mm

Height: 1830 mm

Depth of the product: 731 mm

Net weight: 117.3 kg

Door panel options: Not possible

Door hinge: Left & Right

Number of Adjustable Shelves in fridge compartment (Stck): 2

Shelves for Bottles: No

Interior ventilator: Yes

Reversible Door Hinge: No

Length of electrical supply cord: 240.0 cm

Noise level: 38 dB(A) re 1 pW

Multi-Flow Air Tower: Yes

Fast cooling switch: Yes

Fast freezing switch: Yes

Temperature Controlled Drawer: No

Humidity Control Drawer: No

Number of Door Bins - Refrigerator: 4

Door bin adjustability - Refrigerator: Yes

Tilt-out door bins in fridge: Yes

Gallon Storage: Yes

Number of Gallon storage: 2

Motorized Shelf: No

Material of the shelves: Safety glass

Door opened indicator freezer: No

Automatic motor-driven ice-maker: No

Fuse protection: 10 A

Voltage: 220-240 V

Frequency: 50-60 Hz

Storage Period in Event of Power Failure (h): 15 h

Main colour of product: Inox-easyclean

Door panel options: Not possible

Noise level: 38 dB(A) re 1 pW

Energy Star Qualified: No

Plug type: GB plug

Required cutout/niche size for installation (in): x

Dimensions of the packed product: 74.99 x 39.29 x 30.23

Net weight: 259.000 lbs

Gross weight: 282.000 lbs



Series 4, French door bottom freezer, multi door, 183 x 90.5 cm, Inox-easyclean KFN96VPEAG

This multi door refrigerator with VitaFresh Box: cools very efficiently - thanks to the cooling compartment, your fruits and vegetables stay fresh longer.

Performance and Consumption

- EU19_EEK_D: E
- Total Volume : 605 l
- Net Fridge Volume : 405 l
- Net Freezer Volume : 200 l
- Freezing capacity 24h : 13 kg
- Annual Energy Consumption: 333 kWh/a
- Climate Class: SN-T
- EU19_Fast freezer facility_D
- Noise Level : 38 dB , EU19_Noise emission class_D: C
- Temperature rise time : EU19_Temperature rise time_D: 15 H
- No Frost, Free-standing-refrigerator >= 3 door

Design features

- Standard door Stainless Steel EasyClean
- Standard door
Stainless Steel EasyClean door and chrome inox metallic side panels.
- Electronic control for fridge and freezer with LED display
- Interior design with metal applications

Functions

- Super Cooling: automatic deactivation
- Automatic defrost fridge
- Sabbath Mode
- optical, Optical and acoustical door open warning
- Freezer malfunction warning signal: optical, acoustical

Food freshness system

- MultiAirflow system - improves circulation of air around the fridge
- 1 VitaFresh drawer - Fish and meat stay fresh for longer
- 1 CrisperBox - vegetable/salad container with humidity control

Dimension and installation

- Dimensions: 183 cm H x 90.5 cm W x 73.1 cm D
- 4 wheels for easier transport, 3 of them height adjustable.
- 220 - 240 V

Key features - Fridge section

- Bright interior LED fridge light in fridge section
- 3 safety glass shelves of which 2 are height adjustable, Standard shelf 2 shelves extendable
- Bright interior LED fridge light
- Door shelves in fridge door: 2 large and 2 small.
- 1 dairy compartment in door
- 2 removable door storage compartments.
- 3 safety glass shelves (2 height adjustable)
- White glossy back wall

Key features - Freezer section

- No Frost
- Freezer malfunction warning signal: Acoustic Warning System
- Net 4* compartment volume : 200 l
- 6 freezer drawers
- 1 ice cube tray
- Based on the results of the standard 24-hour test. Actual consumption depends on usage/position of the appliance.
- To achieve the declared energy consumption, the distanceholders have to be used. As a result, the appliance depth increases by about 3.5 cm. The appliance used without the distance holder is fully functional, but has a slightly higher energy consumption.

Series 4, French door bottom freezer, multi door, 183 x 90.5 cm, Inox-easyclean KFN96VPEAG

measurements in mm

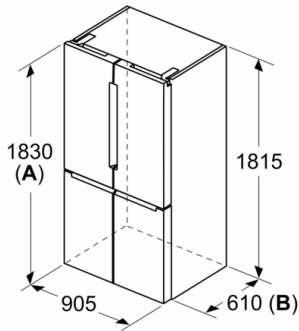

A: Front is adjustable from 1830 to 1847, with front levelling feet fully extended
B: Add 25 for fixed spacers on back

measurements in mm

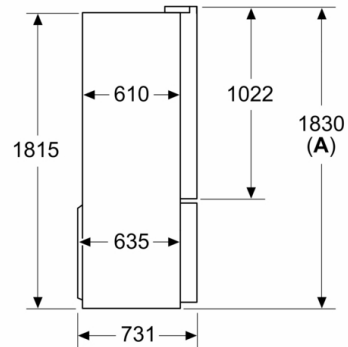

A: Front is adjustable from 1830 to 1847, with front levelling feet fully extended

Measurements in mm

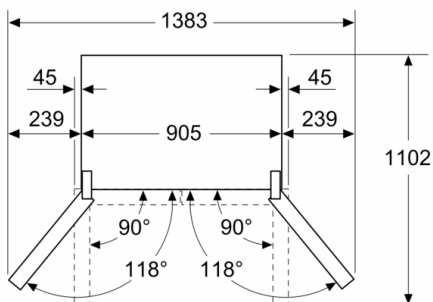

Measurements in mm

