

Cafe PLUS
Capsule Machine
Instruction Manual & Guarantee

Dualit[®]
Since 1945

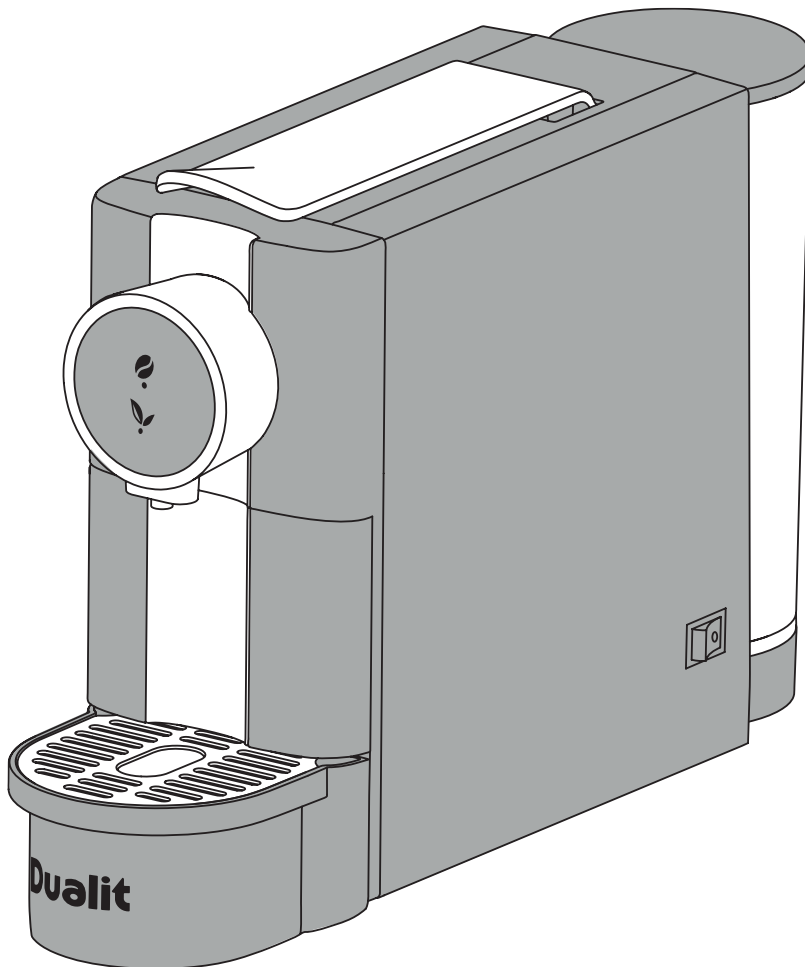

YOUR CAPSULE MACHINE

High pressure capsule machines, such as your new Dualit Capsule Machine, require constant care and maintenance to prolong their life.

Please remember to:

- **Rinse through before first use and after every use.**
- **Descale your machine on a regular basis.**



PERFECT PARTNER

(SOLD SEPARATELY)



MILK FROTHER

www.dualit.com/milk-frother



DUALIT TEA & COFFEE CAPSULES

www.dualit.com/capsules

DON'T FORGET TO REGISTER YOUR PRODUCT	WWW.DUALIT.COM/REGISTER	Register my appliance ✓
	OR BY POST	

Unpack the box with care, keeping all the packaging materials until you are satisfied everything is present and in working order. Once satisfied remove any tags from the appliance body and recycle the packaging appropriately. Do not remove tags from the cord. You may wish to keep the box to store your appliance.

All illustrations are for representation only, your model may have a different appearance from illustrations shown.

CONTENTS

Safety Precautions	04
Before First Use	05
Know your Capsule Machine	06
First use	07
Daily use	08
Programmable dosing memory	10
Auto-Start	11
Descale Mode	12
Cleaning - after each use	13
Troubleshooting	14
Barista Training & Coffee Guide	18
Fine Tea Tasting Notes & Tea Guide	19
Guarantee	23

JOIN THE CAPSULE CLUB

- Quick re-ordering
- Great taste, great rewards
- Be inspired

WWW.DUALIT.COM/CAFECUB



IMPORTANT SAFETY PRECAUTIONS

READ ALL INSTRUCTIONS

BEFORE USING THE CAPSULE MACHINE. KEEP THESE INSTRUCTIONS FOR FUTURE REFERENCE.

IMPORTANT SAFEGUARDS

- **THIS IS AN ATTENDED APPLIANCE. Do not leave unattended during use, unplug after each use (risk of fire if an unattended appliance is left operating).**
- This appliance must not be used by children younger than 8 years old or persons with very extensive and complex disabilities. Children aged 8-14 years and persons with reduced physical, sensory or mental capabilities or lack of experience and knowledge shall not use this appliance, unless they are supervised and have been given instruction concerning the use of the appliance in a safe way and understand the hazards involved. Children shall not play with the appliance. Cleaning and user maintenance shall not be made by children unless they are older than 8 and supervised. Keep the appliance and its cord out of reach of children less than 8 years old.
- This appliance is intended for indoor household use only. If the appliance is used improperly or for professional or semi-professional purposes or if it is not used according to these instructions the Guarantee becomes invalid and Dualit refuses any liability for damage caused.

Electrical safety

- Ensure that the voltage of the appliance corresponds to that of the mains supply.
- **WARNING:** This appliance must be earthed.
- Unplug the appliance from the mains before cleaning or maintaining. For details, please refer to CLEANING SECTION.
- Do not operate this appliance with a damaged cord or plug. If the supply cord is damaged, it

must be replaced by Dualit Ltd, its service agent or a similarly qualified person in order to avoid a hazard.

- Never touch the cable with wet hands.
 - This appliance conforms to directive 2014/30/EU regarding electromagnetic compatibility.
 - Do not pull the power supply cable over sharp edges, clamp it or allow it to hang down. It should not be allowed to come into contact with hot or damp surfaces.
 - The use of extension cables not authorised by the manufacturer may cause damage or accidents.
- General safety**
- **Do not use if dropped, cracked or damaged. Risk of fire, electric shock or injury to persons.**
 - **The use of accessory attachments not recommended by Dualit may result in fire, electric shock or injury to persons.**
 - Product surface and inside is subject to residual heat after use.
 - Do not touch the metal body when the appliance is in use, as this may cause burns or scalding.
 - Do not place the appliance on a polished wood surface, it could damage the surface.
 - Do not place on a metal tray or surface that may collect liquid or other metal surface during use.
 - Do not operate on an uneven surface.
 - Do not place the appliance over or close to sources of heat such as electric rings, hot ovens or open flames.
 - Do not use the appliance without water as this may cause damage to the pump.
 - Do not leave the appliance in a room with a temperature below 0°C, as any water remaining in the appliance could freeze and cause damage.
 - The coffee maker shall not be placed in a cabinet when in use.
 - **Before refilling the water tank, unplug the appliance from the mains. Never remove the water tank whilst plugged in.**
 - Do not overfill the water tank.

- Do not fill water tank whilst it is fitted to the machine.
- Do not use sparkling water (with carbon dioxide).
- Never fill the tank with hot or boiling water.
- Only use the appliance with the drip tray correctly fitted.
- Do not immerse in water or other liquids.
- Do not use the coffee machine for any purpose other than mentioned in this instruction booklet. Otherwise, this may result in an injury caused by misuse.
- **If there is internal water leakage, do not operate the capsule machine and unplug it at once in order to avoid electric hazard. Please note, condensation under the machine is normal.**
- Turn the appliance off and unplug when not in use.
- To prevent damage to the appliance do not use alkaline cleaning agents when cleaning, use a soft cloth and a mild detergent.
- Do not use a scouring pad or abrasive cleaner on the main body.
- Hot water hazard. Avoid direct contact with hot water. Unplug the appliance from the mains to allow to cool before cleaning, maintaining or moving. For details, please refer to cleaning section.
- We recommend that the appliance is plugged into a socket that has no other appliance connected to it. Failure to do this may cause an overload, trip a circuit breaker or blow a fuse. Preferably the socket outlet should be protected by a residual current device (RCD).
- Do not come into contact with the coffee outlet, risk of scalding.
- Never use a damaged or deformed capsule. Water could flow around the capsule when not perforated by the blades and damage the appliance.
- This appliance operates with Dualit NX®, Dualit Fine Tea and Nespresso® capsules.
- Always close the lever completely and never lift it during operation. Do not put fingers into the capsule compartment or the capsule shaft. Danger of injury!

- Never put the appliance or part of it in a dishwasher.

SAVE THESE INSTRUCTIONS

In the interest of improving products, Dualit Ltd. reserves the right to change the product specification without prior notice. All illustrations are for representation only, your model may vary from illustrations shown.

INSTRUCTIONS ON ENVIRONMENT PROTECTION



Do not dispose of this product in the usual household garbage at the end of its life cycle. Please hand it over to a collection point for the recycling of electrical and electronic appliances.

The symbol on the product, the instruction of use or the packaging will inform you about the methods of disposal. The materials are recyclable as mentioned on its marking. By recycling, material recycling or other forms of re-utilization of old appliances you are making an important contribution to protect our environment. Please enquire at the community administration for the authorised disposal location.

IMPORTANT: BEFORE FIRST USE THE COFFEE MACHINE MUST BE FLUSHED THROUGH WITH WATER BEFORE THE FIRST USE.

1. Follow the instructions as if priming the appliance, ensuring no capsule is inside.
2. Press the Coffee Button once to dispense water. Then repeat 5 times. This will rinse the internals ready for your first drink.
3. The water tank must be washed with warm soapy water, then rinsed and dried.

* Nespresso® trademark is owned by Société des Produits Nestlé S.A



KNOW YOUR CAPSULE MACHINE

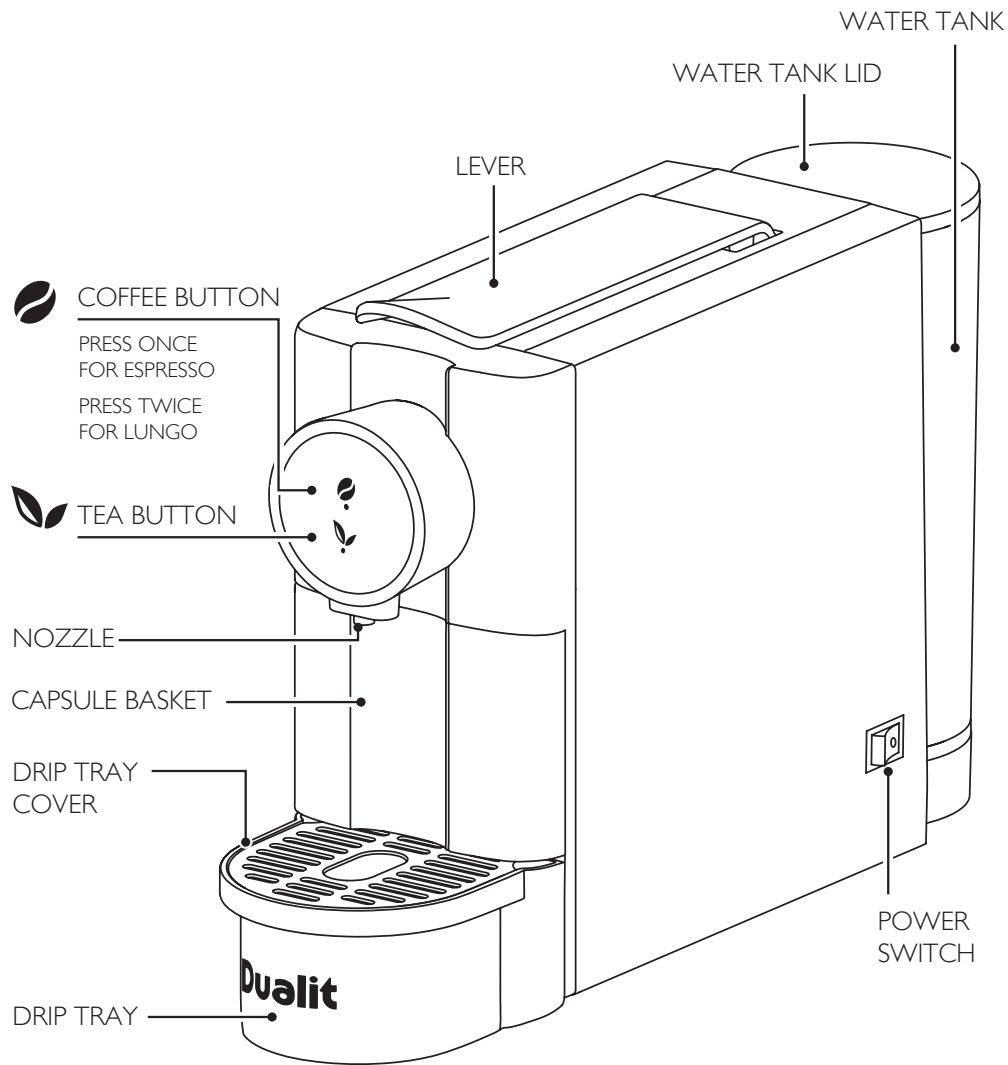

FIRST USE

To achieve optimum performance from your Capsule Machine follow this procedure for first use or if you have not used your machine for a prolonged period. **SAFETY INSTRUCTION: Never lift the lever whilst the beverage is being dispensed. Hot beverage may cause injury and burns.**

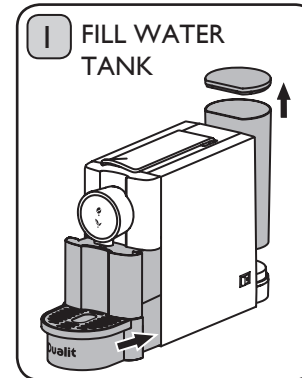

Insert the Capsule Basket into the Drip Tray, then slide into the machine. Lift the Water Tank and remove the Water Tank Lid. Carry to the tap and fill with water. **Do not overfill or fill whilst attached to the capsule machine.**

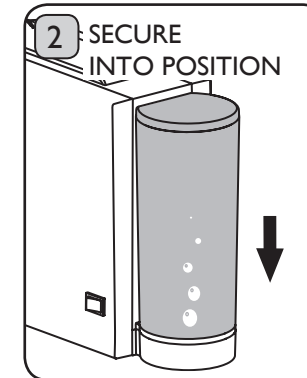

Once filled, place the Water Tank into position by aligning the connection and pushing down firmly. Tip: bubbles rise in the Water Tank when it is correctly seated.

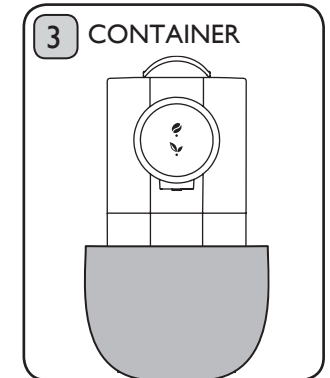

Remove the Drip Tray and Capsule Basket assembly, then place a container or large cup under the Nozzle. Ensure the Lever is pushed down fully.

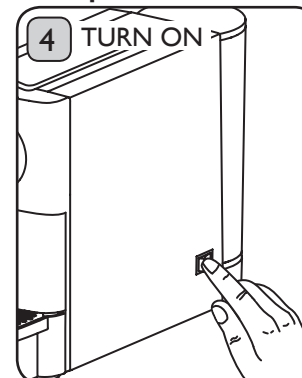

Plug in the power cord at the mains and turn on using the Power Switch. Coffee & Tea Buttons will flash slowly to indicate machine is warming up.

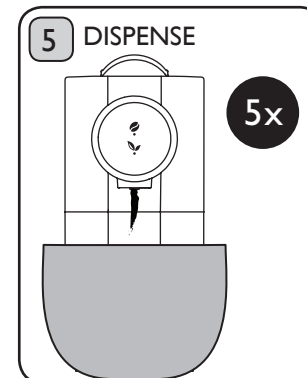

The machine is warmed up once the Coffee & Tea Buttons stop flashing. Press the Coffee Button and wait for the water to dispense. Repeat 5 times. This will rinse the internals ready for your first drink.

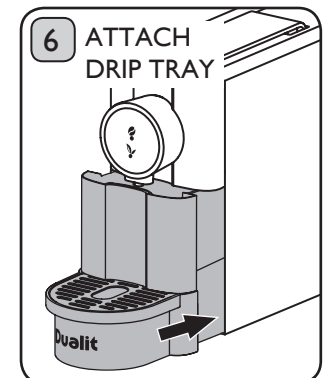

Slide the Drip Tray and Capsule Basket assembly into the machine.

DAILY USE - DISPENSING COFFEE OR TEA

To achieve optimum performance from your Capsule Machine follow this procedure. **SAFETY INSTRUCTION: Never lift the lever whilst the beverage is being dispensed. Hot beverage may cause injury and burns.**

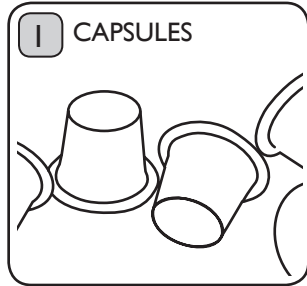

Compatible with Dualit NX coffee capsules, Fine Tea capsules and Nespresso coffee capsules. Dualit NX® & Fine Tea capsules, are available directly from supermarkets, independent retailers, online at www.dualit.com/capsules and Dualit Sales: 01293 652500 (UK delivery only).

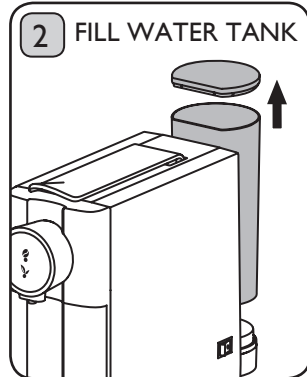

Unplug the machine then remove and fill the Water Tank. Once filled, secure back into position.

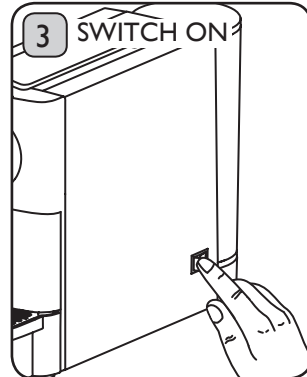

Plug in the power cord at the mains and use the Power Switch to switch on. Ensure Lever is down. Coffee & Tea Buttons will flash slowly to indicate machine is warming up.

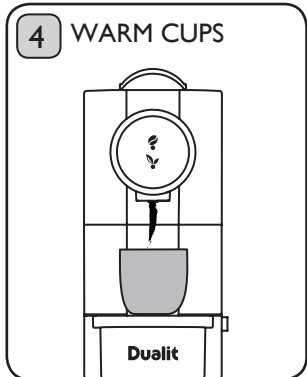

Place a cup on the Drip Tray. **For best results**, pre-warm the cup by dispensing hot water into the cup before inserting a capsule. Dispose of water before dispensing coffee.

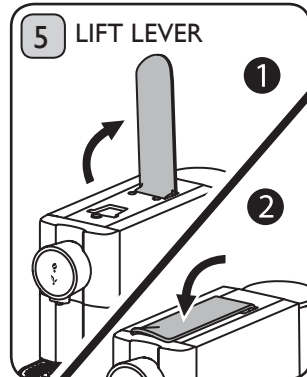

Lift the Lever fully and insert a capsule. Ensure capsule is not damaged or deformed. If so, discard and use a new capsule. Then push the Lever down fully.

DAILY USE - CONTINUED

To ensure the best taste and no flavour transfer, you should always dispense hot water to rinse the system when switching between coffee and tea.



Press the Coffee Button **once** to dispense an Espresso. The Coffee Button will illuminate blue. Press **twice** to dispense a Lungo, the Coffee Button will flash blue slowly.

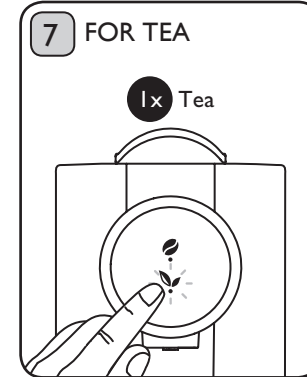

Press the Tea Button once to dispense tea; the Tea Button will illuminate green. Note: Tea extracts at a higher temperature to coffee.

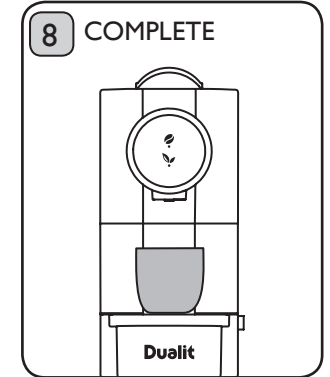

The Coffee & Tea Buttons will illuminate once dispense has finished. Your beverage is now ready to be consumed. Note: The Buttons may flash to indicate that the machine is warming up ready for next use.

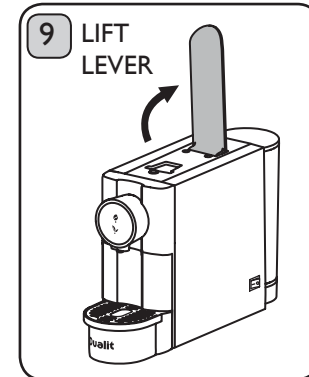

Lift the Lever fully, to empty the capsule into the Capsule Basket. We recommend the Capsule Basket is emptied after use.

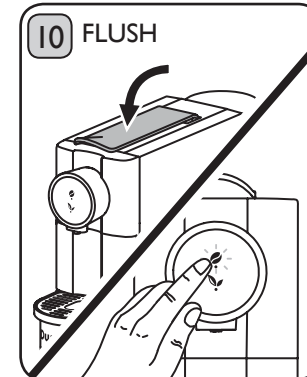

After using the machine we recommend flushing the machine through. Ensure the Lever is pushed down fully and press the Coffee Button. Water will flush through the machine and into the Drip Tray.

Note:

- Do not use a Coffee capsule in Tea mode.
- Switch off and unplug after use.
- Do not leave capsules in machine after use.
- Your machine is fitted with a Descale indicator. If the Coffee & Tea Buttons flash quickly immediately after switching on the machine, then descaling is required. See page 12 'Descale Mode'.
- Empty Drip Tray regularly.

PROGRAMMABLE DOSING MEMORY

The Capsule Machine has an Auto-Dose feature that ensures the correct amount of drink is dispensed every time. Ensure the machine has enough water in the Water Tank and is switched on.

NOTE - The factory setting of the machine is programmed to 35ml for the Espresso button, 70ml for the Lungo button and 180ml for the Tea button. However, this can be adjusted to suit your taste preference.

For tea, we recommend using 1 capsule for a 150-180ml tea cup (depending on your strength and taste preference). For a mug (250ml) we recommend using 2 capsules and setting your dose to 125ml.

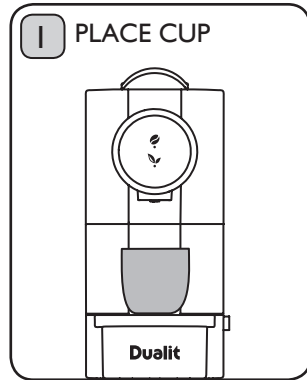

Open the Lever fully and insert a capsule. Then push the Lever down fully. Place a cup on the Drip Tray.



Press the Coffee Button **once** and **hold for 5 seconds**, then release. The machine will start dispensing. Press the Coffee Button again when the desired amount is reached, and the dispensing will stop.

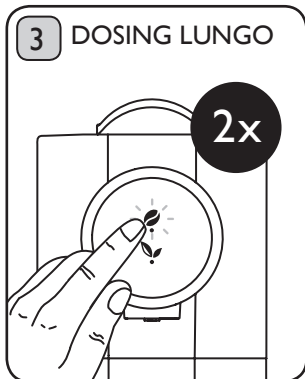

Press the Coffee Button **twice** and **hold for 5 seconds**, then release. The machine will start dispensing. Press the Coffee Button again when the desired amount is reached, and the dispensing will stop.

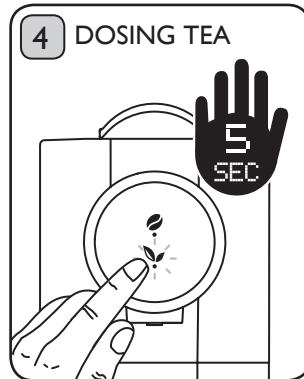

Press the Tea Button **once** and **hold for 5 seconds**, then release. The machine will start dispensing. Press Tea Button again when the desired amount is reached and the dispensing will stop.

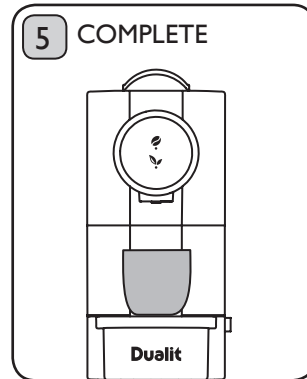

The Dosing Memory has now been programmed to dispense your chosen quantity of coffee or tea. **NOTE:** program will be saved even if machine is unplugged.

AUTO-START

The Auto-Start feature allows you to pre-select your dose whilst the machine is warming up. Then, once the machine has warmed up it will automatically dispense the selected Coffee or Tea.

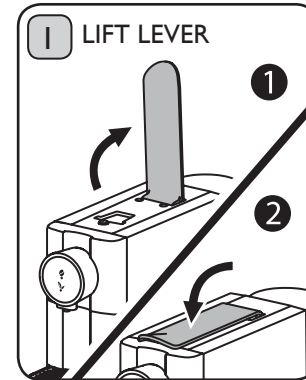
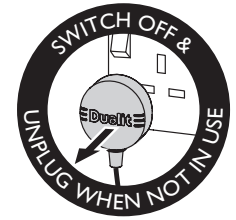

Lift the Lever fully and insert the capsule. Then close the Lever fully. The Coffee & Tea Button will be flashing to indicate that the machine is warming up when the machine is turned on.

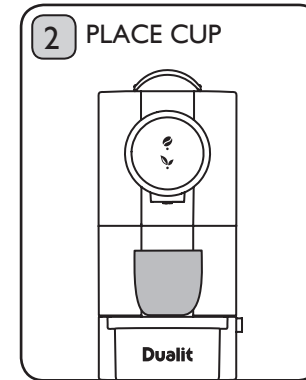

Place a small cup on the Drip Tray. If you like a particularly hot coffee, we recommend pre-warming the cup first (see page 8 'Daily Use').

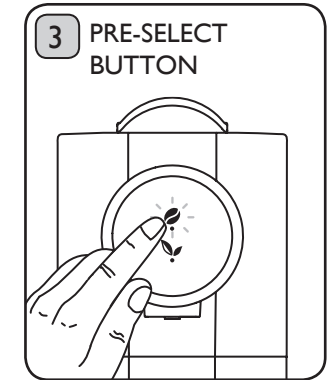

Whilst the machine is warming up, press the Coffee Button **once** for Espresso, **twice** for Lungo or press the Tea Button **once** for tea. The selected Button will flash and the other Buttons will cease to illuminate. Tip: press Buttons firmly.

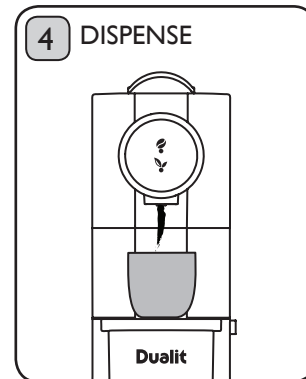

The machine will now auto dispense the selected beverage, once it has warmed up.

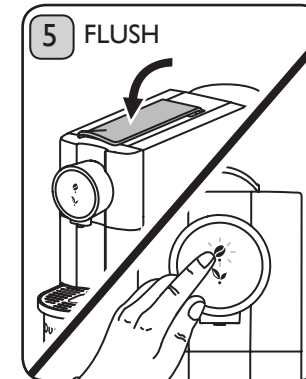

After using the machine we recommend flushing the machine through. Remove capsule and ensure the Lever is pushed down fully, then press the Coffee Button. Water will flush through the machine and into the Drip Tray. Empty the Drip Tray, **switch off and unplug after use.**

DESCALE MODE

Dualit recommends descaling regularly to prevent limescale build up in the machine. Your machine has a Descale Counter which will indicate to the user that the machine requires descaling. **IMPORTANT NOTICE: PRODUCT FAILURE DUE TO THE BUILD UP OF LIMESCALE IS NOT COVERED BY GUARANTEE - PLEASE DESCALE REGULARLY.**

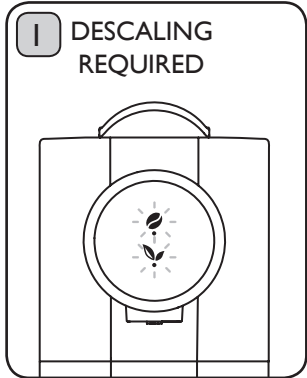
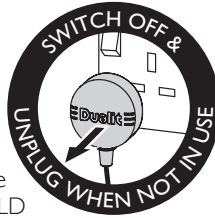

The Coffee & Tea Buttons will quickly flash, immediately after switching on, to indicate descaling is required. Ensure your descaling product is suitable for coffee machines and follow descaling product instructions carefully.

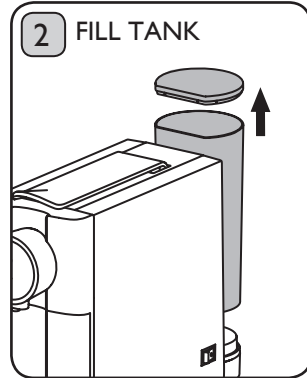

Ensure the correct ratio of water is used to create the Descaling Solution. Turn the machine off, remove the Water Tank and fill with the Descaling Solution. Remove Drip Tray and place large container under the nozzle.



Insert Water Tank. Turn on and wait for the Coffee & Tea Buttons to stop flashing. Press **both** Coffee & Tea Buttons firmly at the same time and **hold for 5 seconds**. Both Buttons will now quickly flash.

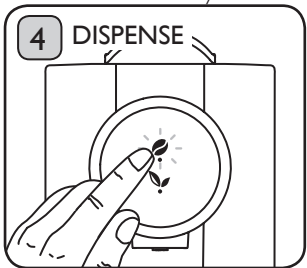

Ensure the Lever is pushed down fully and no capsule is present, then press the Coffee Button to start descaling. Your machine will dispense. This will continue until the Water Tank is empty. Wait 10 minutes for the Descaling Solution to take effect.

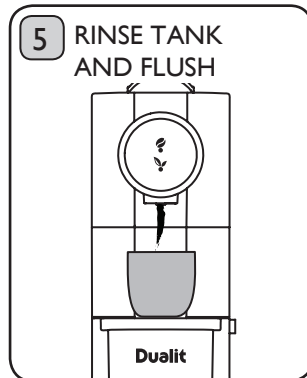

Rinse the Water Tank and fill with fresh water. Repeat step 4 (Dispense) and **flush at least two full tanks of water through the machine** to remove any traces of the Descaling Solution.

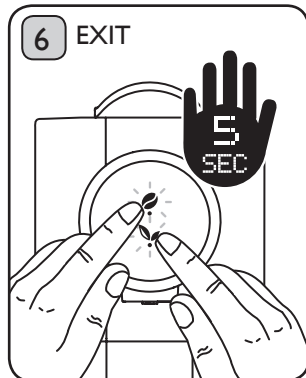

To exit the Descale Mode, press **both** Coffee & Tea Buttons at the same time and **hold for 5 seconds**. Both lights will go back to solid illumination. **NOTE:** if the machine is turned off in Descale Mode, it will stay in this mode when switched back on.

CLEANING - AFTER EACH USE

BEFORE CLEANING, MAKE SURE THERE IS **NO CAPSULE** IN THE MACHINE, FOLLOW STEP 1 AND THEN SWITCH OFF, UNPLUG AND ALLOW TO COOL.

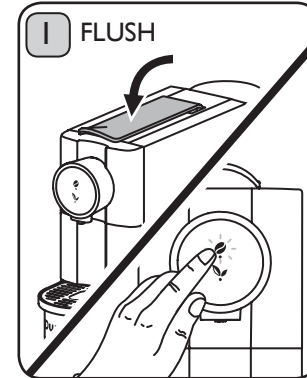
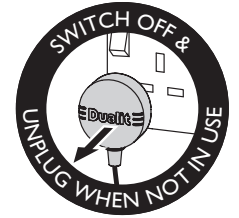

Ensure the Lever is pushed down and no capsule is present. Press the Coffee Button. Water will flush through the machine and into the Drip Tray. Then **switch off, unplug and allow to cool**.

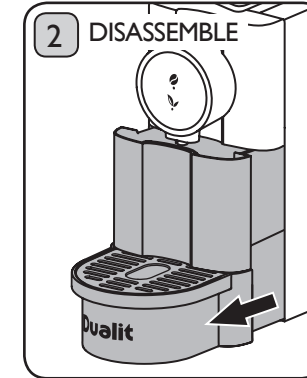

Remove the Drip Tray and Capsule Basket assembly, then lift the Capsule Basket out of the Drip Tray. **WARNING: Drip Tray will be hot after use. Handle with care - risk of scalding.**

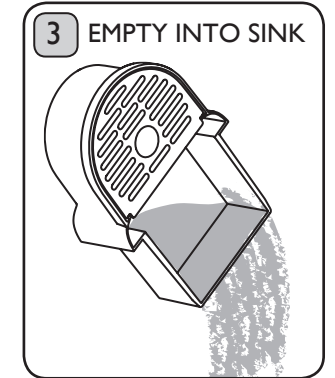

Empty and rinse the Drip Tray in the sink to remove any liquid that may have collected.

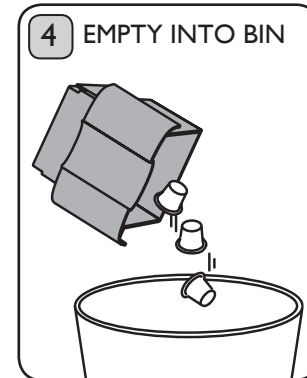

Dispose of the used capsules left in the Capsule Basket. If using Dualit compostable capsules, dispose of via your council food waste collection.

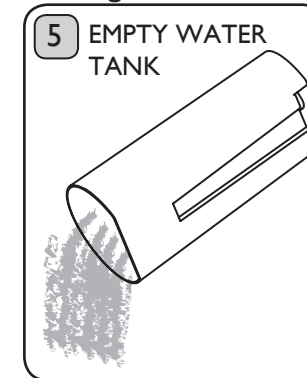

Empty and rinse out Water Tank after each session and refill with fresh water, just before you make your next beverage.

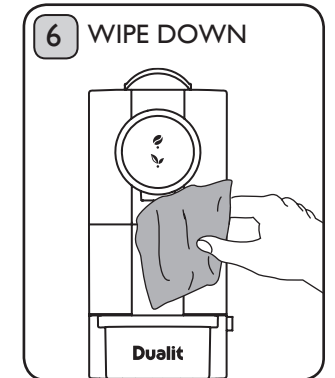

Wipe down the body and Nozzle of the capsule machine with a damp, non abrasive cloth.

TROUBLESHOOTING GUIDE

IMPORTANT NOTICE: PRODUCT FAILURE DUE TO THE BUILD UP OF LIMESCALE IS NOT COVERED BY GUARANTEE - DESCALE REGULARLY.



POSSIBLE CAUSE(S)	SOLUTION(S)
THE CAPSULE MACHINE DOES NOT TURN ON	
The unit may not be properly connected to the power supply.	<ol style="list-style-type: none"> 1. Check the plug is in the socket and the switch is turned on. 2. Check and replace the fuse if necessary. Note: in order to open the plug, remove the label to reveal the screw. 3. The machine may be in Standby Mode, which activates automatically after 10 minutes. In this Mode the tea and coffee lights turn off to conserve energy. You can exit Standby Mode by pressing any Button.
THE CAPSULE MACHINE IS NOT DISPENSING TEA OR COFFEE	
The Coffee or Tea Buttons illuminate without flashing, but no tea or coffee is dispensed.	<ol style="list-style-type: none"> 1. The Nozzle could be blocked. Follow the Cleaning instructions on page 13. If this does not clear the blockage refer to page 12 to descale your machine. 2. The inserted capsule could be faulty. Wait a few moments before opening the Lever, flush the machine through and then try again with another capsule. 3. Ensure that the Lever is properly closed and the Capsule Basket is empty. 4. There could be air trapped in the pipework. Remove the capsule and ensure that the Water Tank is full. Press the Coffee or Tea Button. Water should exit the Nozzle. If it doesn't, press again to release the trapped air.
You may have run out of water.	Remove the Water Tank and fill with fresh water.
The Water Tank may not be seated correctly.	Position by aligning the connection and pushing down firmly. Tip: Bubbles rise in the Water Tank when it is correctly seated. Then push the Water Tank Lid down to cover the Water Tank.

MY MACHINE IS MAKING A LOUD NOISE OR EXTRACTION HAS STOPPED MID USE	
1. You may have run out of water (the machine is making a noise and the Buttons are flashing).	Turn the machine off and remove the Water Tank. Refill with fresh water and then place the Water Tank back onto the machine. Follow instructions on page 08-09 before dispensing.
2. There may be an airlock in the pipework.	Remove the capsule and ensure that the Water Tank is full. Press the Coffee or Tea Button. Water should exit the Nozzle. If it doesn't, press again to release the trapped air.
MY CAPSULE MACHINE IS LEAKING	
There is water beneath the capsule machine.	<ol style="list-style-type: none"> 1. There will be a small amount of condensation forming underneath the capsule machine after making numerous beverages. This is safe and does not mean the machine is leaking. 2. Ensure that the Water Tank has been correctly inserted. When refilling with water, always switch off the capsule machine and only then remove and refill the Water Tank. Otherwise, water could leak from the appliance. If you still feel the capsule machine is leaking, stop, unplug and contact Dualit on (+44) 01293 652500.
MY COFFEE HAS NO CREMA	
Little to no crema is produced.	<ol style="list-style-type: none"> 1. Each time coffee is dispensed, essential oil is deposited in the Nozzle. Descale and follow instructions on page 12-13. 2. Use Dualit or Nespresso® capsules. 3. Check your capsules are in date. Stale coffee affects crema and taste. 4. Ensure that you are not using the Tea Button for Coffee.

TROUBLESHOOTING GUIDE

FACTORY SETTINGS	
What is the factory setting of the capsule machine?	The factory setting of the machine is programmed to 35ml for the Espresso Button, 70ml for the Lungo Button and 180ml for the Tea Button.
Can I change the factory settings?	Yes. Please follow 'Programmable Dosing Memory' on page 10.
COFFEE & TEA BUTTONS	
What happens if I repeatedly press the Buttons while tea or coffee is being dispensed?	The capsule machine interrupts the dispensing of the tea or coffee prematurely.
Is the Programmable Dosing Memory deleted when the appliance is unplugged?	No, the programming is not affected by unplugging the appliance.
The Buttons flash for a long time. When is the capsule machine ready to use?	It takes a little time for the capsule machine to achieve the optimum water temperature (approx. 30-60 seconds). Once it does, the Buttons will illuminate and will be ready to dispense tea or coffee.
CAPSULES	
The capsule does not drop automatically into the Capsule Basket when I lift the Lever.	1. The Capsule Basket could be full. Please empty it. 2. Ensure that you fully lift the Lever.
The capsule cannot be inserted correctly.	The Capsule Basket could be full. Please empty it.
BUTTONS ARE FLASHING ALTERNATELY AND THE MACHINE IS NOT DISPENSING	
The Water Tank is empty	Fill up the Water Tank & only dispense water
Internal pipes may be blocked	Descale regularly. See page 12.
Faulty flow-sensor	Contact customer services on (+44) 01293 652500.
BUTTONS ARE FLASHING QUICKLY FOR 5-6 SECONDS EVERY TIME MACHINE IS TURNED ON	
Machine is recommending the user to descale.	Enter Descale Mode and follow the instructions on page 12.

PUMP STOPS RUNNING DURING A DISPENSE	
The Water Tank is empty.	Fill up the Water Tank & dispense just water
Internal pipes may be blocked.	Descale regularly. See page 12.
MACHINE TURNS OFF AUTOMATICALLY AFTER A PERIOD OF INACTIVITY	
Machine has entered into Standby Mode after 10 minutes which is an EU approval requirement.	Press Coffee or Tea Button to reactivate the machine. The Buttons will flash and the machine will warm up, ready for use. ALWAYS SWITCH OFF & UNPLUG AFTER USE.
COFFEE & TEA BUTTONS ARE FLASHING QUICKLY EVERY TIME MACHINE IS TURNED ON	
You are in Descale Mode.	Press and hold Tea & Coffee Buttons for 5 seconds to exit.
MY MACHINE IS VIBRATING WHEN DISPENSING	
Your machine has a powerful 19 bar pump which can cause vibrations when machine is placed incorrectly.	Unplug the device and remove the water tank. Ensure the machine is placed on a flat, even surface. Ensure the water tank and capsule basket/drip tray are fully located.
MY COFFEE IS NOT HOT ENOUGH	
Internals have not been pre-heated.	Press the Coffee Button ensuring no capsule is inside the coffee machine; this will run hot water through internal pipework.
Cup or mug is not pre-warmed.	Pre-warm your cup by dispensing hot water into it.
LEVER DOES NOT CLOSE	
The capsule may not be located correctly.	1. Ensure that the capsule is located correctly as per page 8. 2. Ensure the Capsule Basket is not over filled, empty Capsule Basket if full.

BARISTA TRAINING

The Dualit Capsule Machine brings coffee shop style coffee into your home. Let's start with a quick training session and turn you, the coffee drinker, into a barista...





THE PERFECT COFFEE

You are looking for an espresso with a 2-3mm crema and a rich, dark brown colour underneath (the exact colour will depend on the capsule you have chosen).

- It should have a taste that is full of flavour (whether mild and subtle or rich and strong) and should not be bitter. It should stay hot to the bottom of the espresso.
- The Dualit Capsule Machine is designed to produce an optimum Espresso volume of 35ml.
- If you would like a longer drink, extract a Lungo, by pressing the coffee button twice.

To make even more types of coffee please consider our Dualit Milk Frother. This is available directly from www.dualit.com/milk-frother or Dualit sales on 01293 652 500 (UK delivery only).

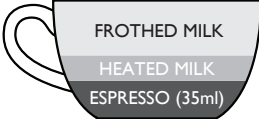
COFFEE GUIDE

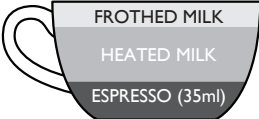
<p>ESPRESSO</p>  <p>ESPRESSO (35ml)</p>	<p>ESPRESSO MACCHIATO</p>  <p>FROTHED MILK ESPRESSO (35ml)</p>	<p>CAFFE LATTE</p>  <p>HEATED MILK ESPRESSO (35ml)</p>
<p>CAPPUCCINO</p>  <p>FROTHED MILK HEATED MILK ESPRESSO (35ml)</p>	<p>AMERICANO</p>  <p>ESPRESSO (35ml) HOT WATER</p>	<p>FLAT WHITE</p>  <p>FROTHED MILK HEATED MILK ESPRESSO (35ml)</p>

FINE TEA TASTING NOTES

ENGLISH BREAKFAST *Exceptionally Luxurious & Smooth*

The leaf, bud and tender stem are hand plucked from tea bushes growing in the finest tea gardens along the East African Rift Valley. Awaken your senses with its bright golden colour, luxurious and smooth taste.

EARL GREY *Elegant & Refreshing*

A distinctive yet aromatic flavour with zesty bergamot. A simply elegant and refreshing premium black tea.

GREEN TEA *Naturally Pure & Delicious*

Experience the well balanced freshness of our pure green tea, delivering refreshingly clean and smooth flavours, from young hand plucked leaves of single origin Kenyan tea gardens.

BLACKCURRANT INFUSION *Irresistible Fruit Explosion*

Bursting with mouth-watering juicy fruit flavours. An intense, velvety blackcurrant taste explosion which is naturally caffeine free.

PEPPERMINT INFUSION *A Soothing & Uplifting Infusion*

Soothing & uplifting pure Peppermint Infusion with invigorating minty freshness. Known for its digestive health benefits and naturally caffeine free.

TEA GUIDE



For a tea cup (150-180ml) we recommend using 1 capsule (depending on your strength and taste preference). For a mug (250ml) use 2 capsules.



Dualit®

JOIN THE CAFÉ CLUB*

- Quick re-ordering
- Great taste, great rewards
- News and inspiration

WWW.DUALIT.COM/CAFECCLUB



DON'T FORGET TO REGISTER YOUR PRODUCT

Take a minute to register your product with us to receive these outstanding benefits:

1 Fast and efficient customer service and access to manuals and product information should you require assistance with your purchase

2 Access to a library of mouth-watering recipes and regular articles from leading chefs, food critics and industry experts

3 Be the first to hear about exciting new Dualit products

Register ✓
my appliance

Dualit recommends safety first: please register your product so that we can contact you in the unlikely event that a safety notification is issued.

WWW.DUALIT.COM/REGISTER

OR BY POST



GUARANTEE

This appliance is of excellent quality and construction. However, if any defects in materials or workmanship do appear during the relevant guarantee period, we will, at our discretion, either repair or replace the defective parts, free of charge, subject to the terms and conditions of our Guarantee shown below.

This Guarantee covers both parts and labour. Carriage is not included.

Your Guarantee period is as follows:

- 1 year

This Guarantee provides benefits which are additional to, and do not affect, your statutory rights. This Guarantee does not cover the cost of returning the product to the dealer from whom it was purchased or to ourselves. This Guarantee applies only to products sold and located in mainland Great Britain. It does not cover liability in respect of or replacement of plugs, cables or fuses and also does not cover defects due to:

- Failure to use or maintain product in accordance with Dualit's instructions.
- The product being connected to an unsuitable electricity supply.
- Accidental damage to or abuse or misuse of the product.
- Product modification except by Dualit or approved agent.
- Dismantling of or interference with the product.
- Theft or attempted theft of the product.

Before returning any product under this Guarantee, please check that:

- You have followed the product instructions correctly.
- Your mains electricity supply is functional.
- The defect is not due to a blown fuse.

If you wish to claim under this Guarantee you should:

- Send the product, postage or carriage paid, to the dealer from whom it was purchased or to Dualit direct.
- Ensure that the product is clean and packed carefully (preferably in its original carton).
- Enclose details of your name, address and telephone number and when and where the product was purchased, together with proof of purchase (e.g. a till receipt).
- Give exact details of the nature of the defect.

This Guarantee does not cover any other claims whatsoever, including, without limitation, any liability for incidental, indirect or consequential damage, nor does it cover any claims for conversion or modification or for the costs of repair carried out by any third party without the prior consent of Dualit. If replacement parts are fitted to the product this will not extend the period of the Guarantee.

For further advice contact the Dualit customer helpline on +44 (0) 1293 652 500 (09:00 to 17:00 Monday to Friday).

Alternatively, email Dualit at info@dualit.com or visit www.dualit.com



Dualit[®]

**NESPRESSO[®]
COMPATIBLE***

**COMPOSTABLE#
CAPSULES**

**REVOLUTIONISING CAPSULES
ONE ESPRESSO AT A TIME**

Sustainability is the vital ingredient in Dualit coffee. Discover quality and great tasting coffee with the benefit of compostable capsules.

Order your coffee at:
www.dualit.com/capsules



* Suitable for drop through machines only. Excluding professional machines and 'built in' models
Nespresso trademark is owned by Société des Produits Nestlé S.A.
Industrial composting by authorised collection schemes

Dualit Limited County Oak Way Crawley West Sussex RH11 7ST
Telephone: +44(0)1293 652 500 Facsimile: +44(0)1293 652 555
Email: info@dualit.com Web: www.dualit.com

