

acctim

14767 SMARTLITE SWEEPER ALARM CLOCK

Thank you for your purchase of this quality clock

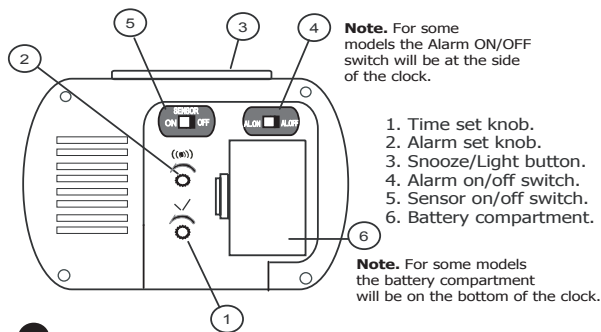

Note. For some models the Alarm ON/OFF switch will be at the side of the clock.

1. Time set knob.
2. Alarm set knob.
3. Snooze/Light button.
4. Alarm on/off switch.
5. Sensor on/off switch.
6. Battery compartment.

Note. For some models the battery compartment will be on the bottom of the clock.

GB

TO START THE CLOCK

Remove the battery compartment cover and insert batteries observing the polarity markings inside the compartment. Replace the cover.

TO SET THE TIME

Turn the 'Time set knob' in the direction of the arrow to set the hour and minute hands to the correct time.

TO SET THE ALARM

Turn the 'Alarm set knob' in the direction of the arrow to the desired wake up time.

TO TURN ON/OFF ALARM

Slide the switch to ON or OFF.

SENSA-LIGHT

It is an innovative feature, that automatically illuminates the dial for easy night-time viewing.

TO TURN ON/OFF SENSA-LIGHT FEATURE

Slide the 'Sensor on/off switch' to on or off position.

SNOOZE/LIGHT

Press the 'Snooze/Light button' to light the dial.
To activate snooze during the alarm, press the 'Snooze/Light button' - after which alarm will sound again approximately 4 - 8 minutes later.

CHANGING THE BATTERIES

It is recommended that you replace the batteries annually even if the product is still running. Only use 2 X AA (1.5V) Alkaline batteries in this clock. Do not mix old and new batteries, different types or brands. Remove the batteries if the clock is stored or not in use. Remove exhausted batteries from the product.

Warning: Do not recharge non-rechargeable batteries.

Please dispose of used batteries in a responsible manner. For more information please contact your local authority.

MAINTENANCE

A soft cloth may be used to clean your clock. Do not use any corrosive cleaner or chemical solutions on the clock. Keep the clock clean and dry to avoid any problems.

YOUR GUARANTEE

Your clock is guaranteed for 12 months from the date of purchase against any faults arising from defective materials or manufacture. Damage caused through careless handling, misuse or in transit is expressly excluded. Should this clock fail within 12 months please return it in the first instance to your retailer.

If you have any queries, problems or do not understand any part of these instructions please contact:

Customer Help Line (01908) 449208 or Locall 0845 1207208
Mon - Fri 9.00am - 4.30pm

email for service: service@acctim.com or visit www.acctim.com

Environmental Protection

Disposal of electrical & electronic equipment

Do not dispose of this product with household waste. For the proper treatment, recovery and recycling please take this product to the appropriate collection point. If you are unsure of where this is contact your local authority. Improper disposal may be harmful to the environment.

