

Amy white bunk Trundle - 190x90 cm

Assembly Instructions - Please keep for future reference

1876965

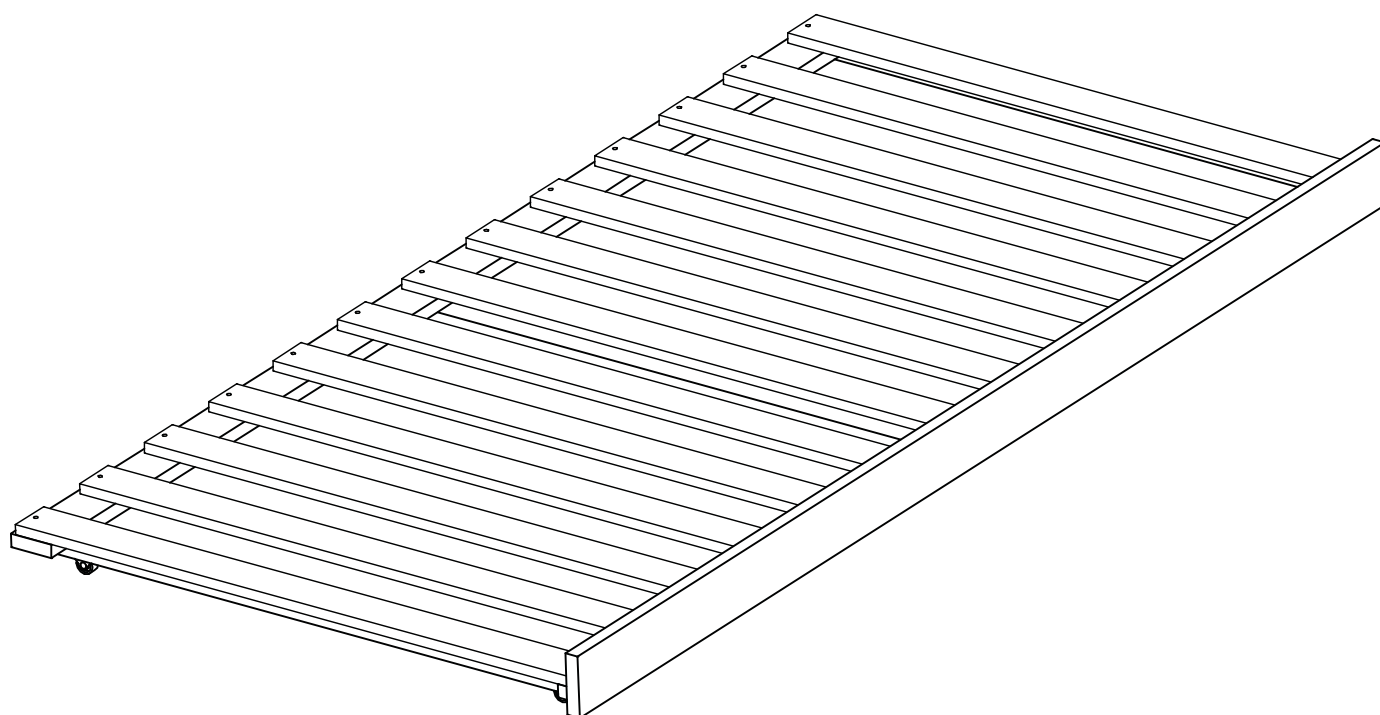

Dimensions

Length - 186cm

Depth - 93cm

Height - 12cm

Weight - 11kg

Important – Please read these instructions fully before starting assembly

If you need help or have damaged or missing parts, call the **Customer Helpline:**

0045 7668 8055 or e-mail: order@flexa.dk



Safety and Care Advice

Important – Please read these instructions fully before starting assembly

- Check you have all the components and tools listed on pages 2 and 3.
- Remove all fittings from the plastic bags and separate them into their groups.
- Keep children and animals away from the work area, small parts could choke if swallowed.
- Make sure you have enough space to layout the parts before starting.

- Do not stand or put weight on the product, this could cause damage.
- Assemble the item as close to its final position (in the same room) as possible.
- Assemble on a soft level surface to avoid damaging the unit or your floor.
- Parts of the assembly will be easier with 2 people.



- We do not recommend the use of power drill/drivers **for inserting screws**, as this could damage the unit. Only use hand screwdrivers.
- Dispose of all packaging carefully and responsibly.

Care and maintenance

- Only clean using a damp cloth and mild detergent, do not use bleach or abrasive cleaners.
- From time to time check that there are no loose screws on this unit.
- This product should not be discarded with household waste. Take to your local authority waste disposal centre.

Components - Parts

If you have damaged or missing components,
call the **Customer Helpline: 0045 7668 8055**

Please check you have all the parts listed below

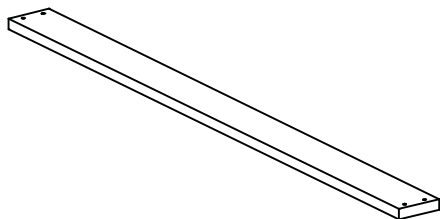

1 Slat x3 (90.0x6.5x1.5cm)
No. 12-01509001

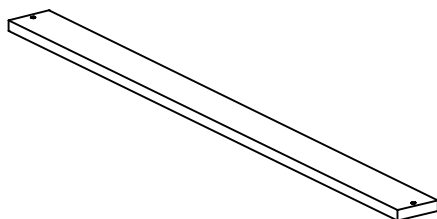

2 Slat x13 (89.7x6.5x1.5cm)
No. 12-01508971

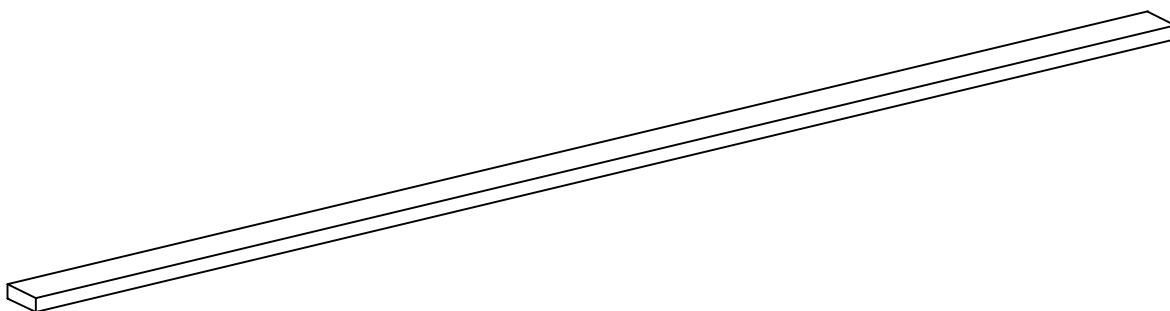

3 Drawer back x1 (184.0x6.5x2.0cm)
No. 12-02018401

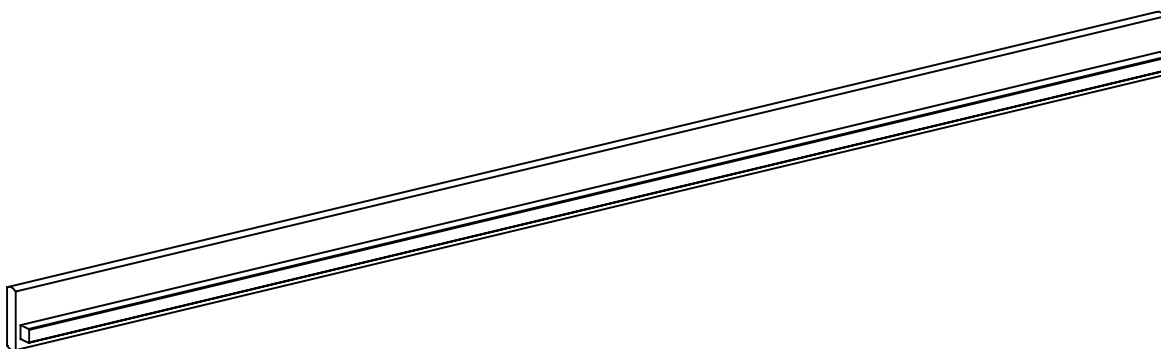



4 Drawer front x1 (185.6x8.9x2.0cm)
No. 1331-18561-20

Components - Fittings

Please check you have all the fittings listed below

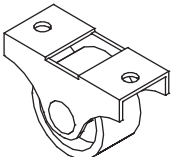
Note: The quantities below are the correct amount to complete the assembly. In some cases more fittings may be supplied than are required.

<p>A  No. 4003-002</p> <p>Ø26mm Castor white wheel x5</p>	<p>B  No. 3901-35030</p> <p>3,5x30mm Chipboard screw x41</p>	<p>C  No. 3902-35012</p> <p>3,5x12mm Chipboard screw x10</p>
---	--	--

Tools required

Phillips
screwdriver
(medium)

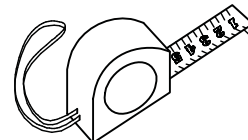
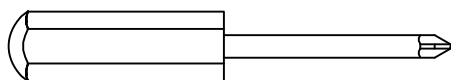

Ruler/tape
measure

Assembly Instructions

Step 1

Attach the slats **1** to the drawer back **3** and to the drawer front **4** with screws **B**.

Please make sure that all are in right angle (90 degrees) before you continue!

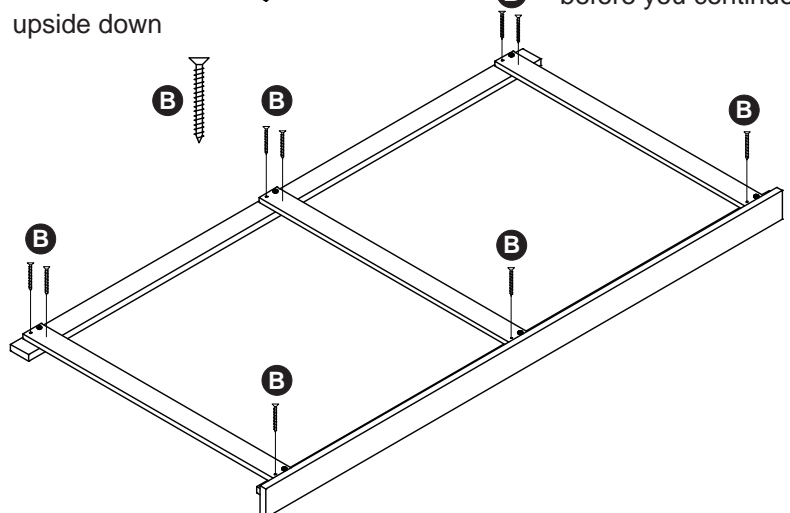
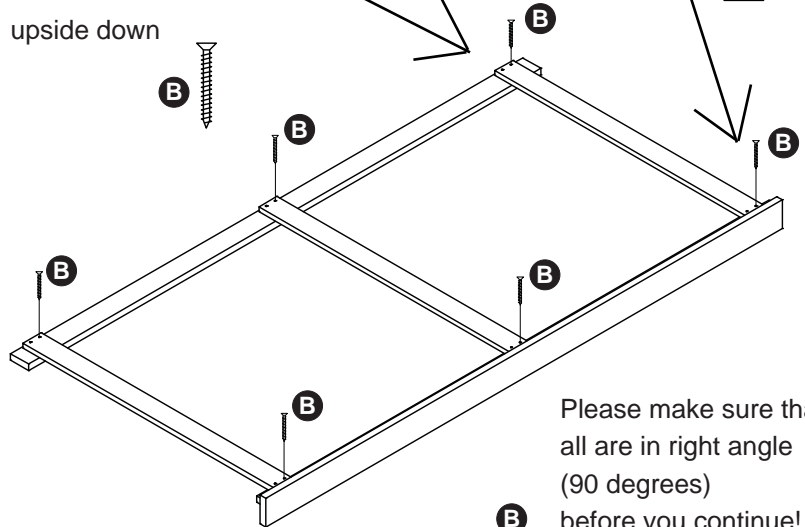
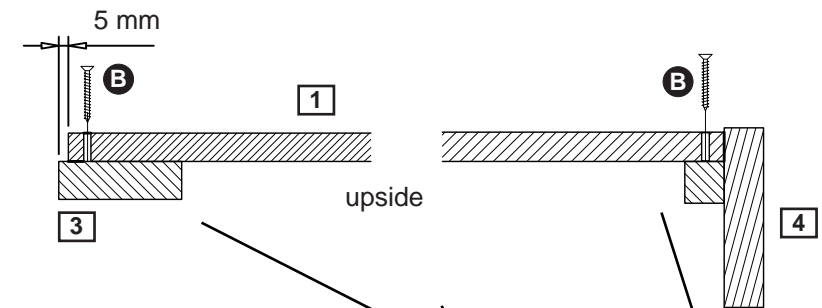
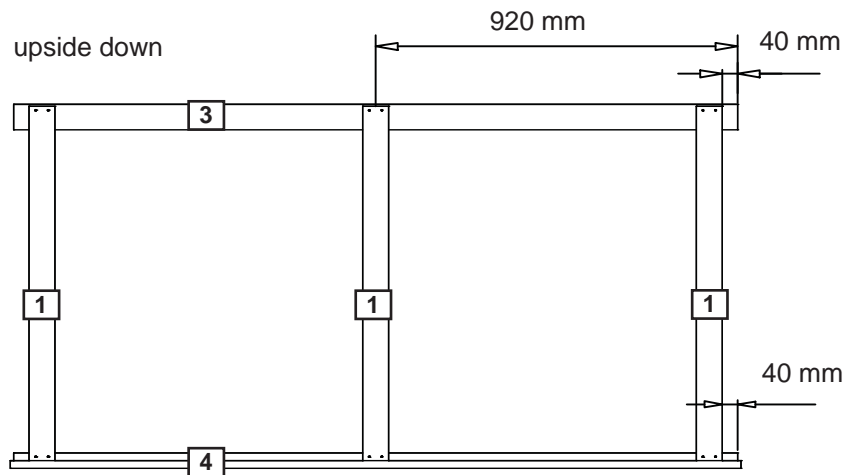

Assembly Instructions

Step 2

Attach the slats **2** to the drawer front **4** and the drawer back **3** with screws **B**.

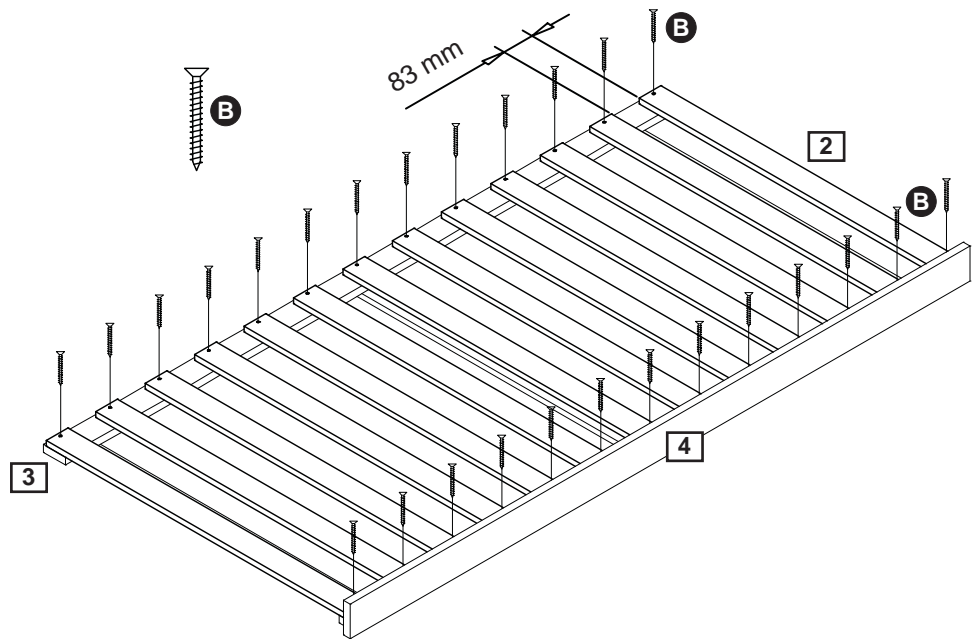
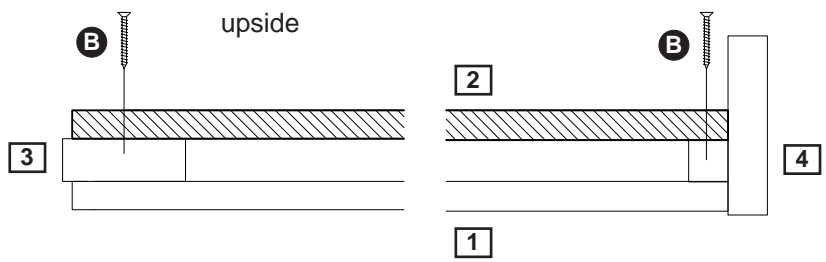

Assembly Instructions

Step 3

Attach the castor wheels **A** to the slats **1** with the screws **C**.

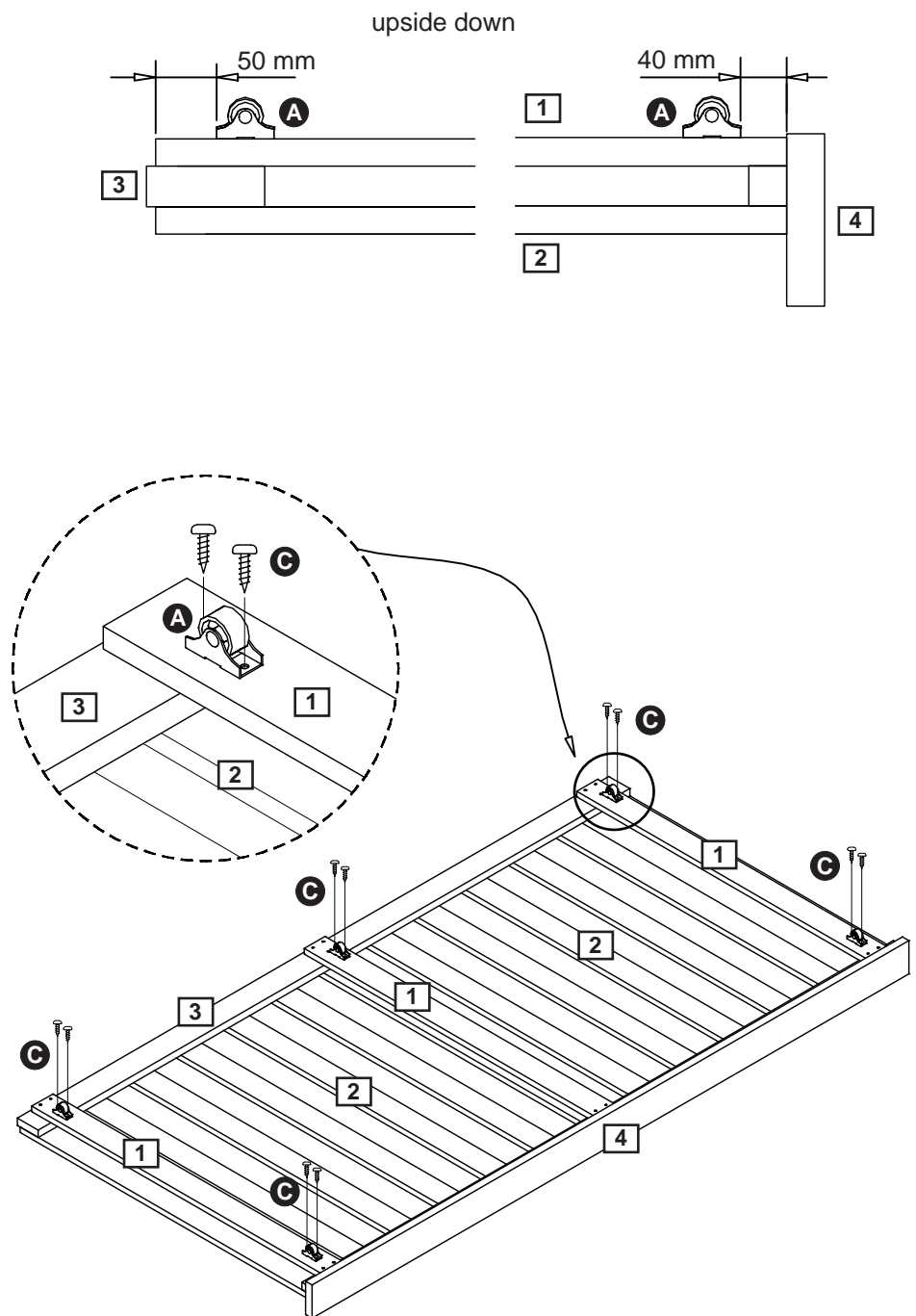

Assembly is complete.

If you need help or have damaged or missing parts, call the **Customer Helpline: 0045 7668 8055**
E-mail: order@flexa.dk