

**Serie | 6, Built-under fridge, 82 x 60 cm, flat hinge
KUR15AFF0G**



The built-under refrigerator with MultiBox: ideal storage location for your fresh fruits and vegetables.

- LED lights bring a completely new lighting concept to fridges
- The egg rack keeps your eggs safe

Technical Data

Gross weight: 82.000 lbs
 Energy Efficiency Class: F
 Average annual energy consumption in kilowatt hour per year (kWh/a): 114 kWh/annum
 Sum of volume of frozen compartments: 0 l
 Sum of volume of chill compartments: 137 l
 Airborne acoustical noise emissions : 38 dB(A) re 1 pW
 Airborne acoustical noise emission class: C
 Construction type: Built-in
 Number of compressors: 1
 Number of independent cooling systems: 1
 Width of the appliance: 598 mm
 Height: 820 mm
 Depth of the product: 548 mm
 Net weight: 34.1 kg
 Required niche size for installation (HxWxD): 820 x 600 x 550 mm
 Door panel options: Possible but accessory
 Door hinge: Right reversible
 Number of Adjustable Shelves in fridge compartment (Stck): 3
 Shelves for Bottles: No
 Frost free system: No
 Interior ventilator: No
 Reversible Door Hinge: Yes
 Length of electrical supply cord: 230 cm
 Noise level: 38 dB(A) re 1 pW
 Multi-Flow Air Tower: No
 Economy setting: No
 Cold technology: 1 compressor/1 cold circuit
 Fast cooling switch: No
 Temperature Controlled Drawer: No
 Humidity Control Drawer: No
 Number of Door Bins - Refrigerator: 3
 Door bin adjustability - Refrigerator: No
 Tilt-out door bins in fridge: Yes
 Gallon Storage: Yes
 Number of Gallon storage: 1
 No. of shelves in fridge: 3
 Motorized Shelf: No
 Material of the shelves: Glass, plastic
 Door opened indicator freezer: No
 Connection rating: 90 W
 Fuse protection: 13 A
 Voltage: 220-240 V
 Frequency: 50 Hz
 Approval certificates: CE, VDE
 Main colour of product: N/A
 Door panel options: Possible but accessory
 Installation type: Built-under
 Noise level: 38 dB(A) re 1 pW
 Energy Star Qualified: No
 Plug type: GB plug
 Required cutout/niche size for installation (in): x x
 Dimensions of the packed product: 35.03 x 26.37 x 24.40
 Net weight: 75.000 lbs



Included accessories

1 x egg tray

Optional accessories

KFZ10AX0 :
 KSZGGM00 :
 KUZ20SX0 :



Serie | 6, Built-under fridge, 82 x 60 cm, flat hinge KUR15AFF0G

The built-under refrigerator with MultiBox: ideal storage location for your fresh fruits and vegetables.

Performance and Consumption

- EU19_EEK_D: F
- Total Volume : 137 l
- Annual Energy Consumption: 114 kWh/a
- Climate Class: SN-ST
- EU19_Fast freezer facility_D
- Noise Level : 38 dB , EU19_Noise emission class_D: C

-
- Fully integrated

Functions

- Ventilation through plinth
- Easy clean interior

Design features

- Mechanical control
- 1 compressor
- Automatic defrost fridge

Design features

- 3 safety glass shelves in fridge compartment of which 3 are height adjustable
- 1 removable door storage compartments.
- Bottle holder in x-deep door tray
- Bright interior LED fridge light

Freshness System

Key features - Fridge section

- Right hinged door, door reversible
- Connection value 90 W
- 220 - 240 V

Dimension and installation

- Niche Dimensions: 82 cm H x 60 cm W x 55 cm D
- Dimensions: 82 cm H x 59.8 cm W x 54.8 cm D

Key features - Freezer section

- KUR15AFF0G

Country Specific Options

- Based on the results of the standard 24-hour test. Actual consumption depends on usage/position of the appliance.

Additional features

Serie | 6, Built-under fridge, 82 x 60 cm, flat hinge KUR15AFF0G

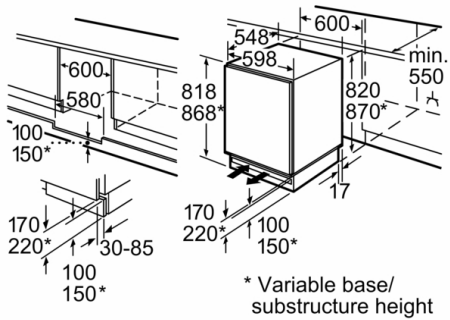

Space for electrical connection next to the appliance on the left or right-hand side.
Ventilation space in the base.

Measurements in mm

measurements in mm
Recommended gap dimensions for flat hinges

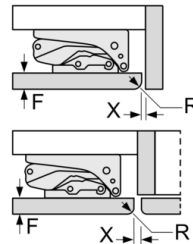

F	R	X
16-19	0-3	2.5
20	0-1	3
	2-3	2.5
21	0-1	3
	2-3	2.5
22	0	4
	1	3.5
	2-3	3

The gap dimensions recommended in the table must be adhered to in order to ensure that appliance doors do not collide with anything when they are opened, and to avoid causing damage to kitchen units.

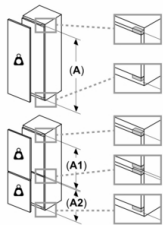

Maximal permissible weight of the unit fronts

Fitted unit fronts that exceed the permissible weight may cause damage and result in functional impairment of the hinges

- Δ Weight
- A: Appliance door height including hinges in mm
- B: Undamped hinge, unit front in kg
- C: Damped hinge, unit front in kg

A	B	C
1500-1750	22	22
720-1400	19	19
A1	15	19
A2	15	19