

# Winslow Bar Stool

Assembly Instructions - Please keep for future reference

600/6400

600/5597

600/5580

600/6280

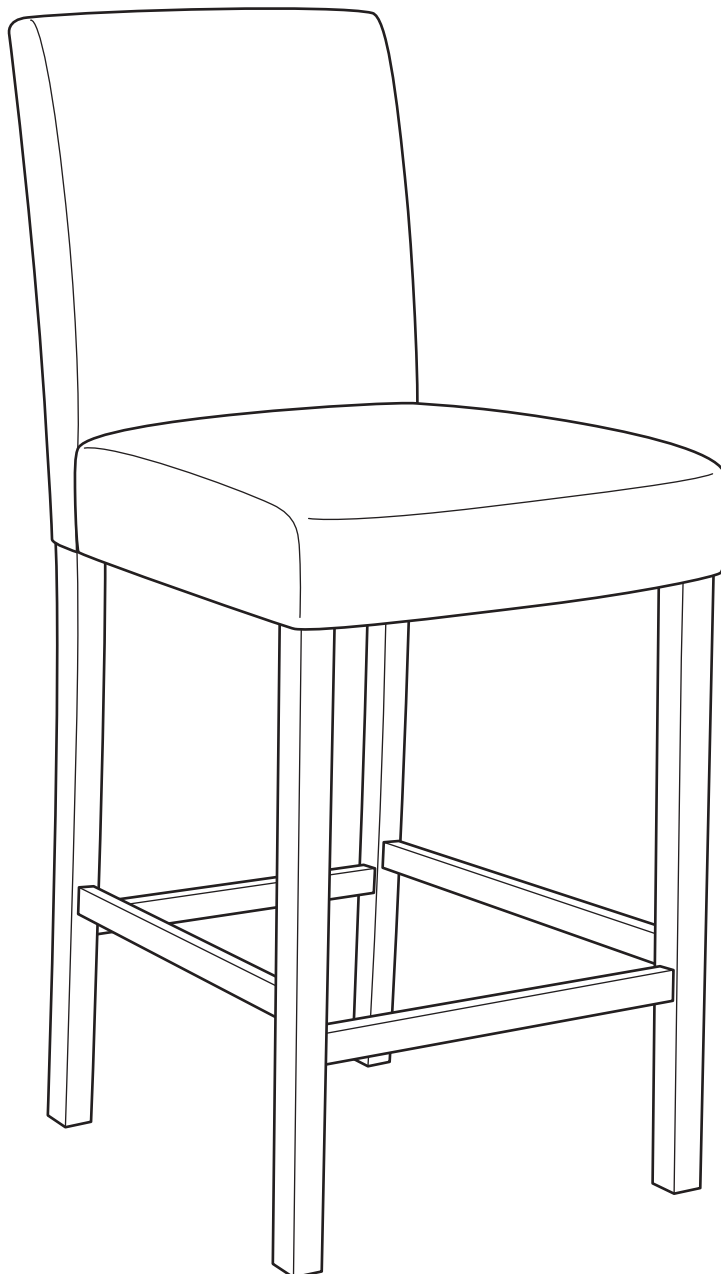

## Dimensions

Width - 41cm

Depth - 52cm

Height - 100.5cm

**Important** - Please read these instructions fully before starting assembly

If you need help or have damaged or missing parts, call the **Customer Helpline: 08456 400800**



# Safety and Care Advice

## Important - Please read these instructions fully before starting assembly

- Assemble this product on a flat surface.
- Assemble all parts loosely before tightening any bolts.
- Do not discard any of the packaging until you have checked that you have all the parts and the pack of fittings.

- Discard all extra fittings and keep fittings out of reach of children.
- Unit weight: 6.9kgs.
- Maximum safe weight of user: 110kgs.
- Retain Assembly Instructions for future reference.



- We do not recommend the use of power drill/drivers **for inserting screws**, as this could damage the unit. Only use hand screwdrivers.
- Dispose of all packaging carefully and responsibly.

## Warnings

- This product should only be used on firm, level ground.
- Make sure the legs remain in contact with the ground.
- Do not stand on the product.

## Care and maintenance

- Please clean the product using either damp (not wet) cloth and a mild domestic soap solution or by using an appropriate polish.
- Do not use any abrasive materials when cleaning.
- From time to time check that there are no loose bolts on this unit.

# Components - Parts

If you have damaged or missing components, call the **Customer Helpline: 08456 400800**

Please check you have all the parts listed below

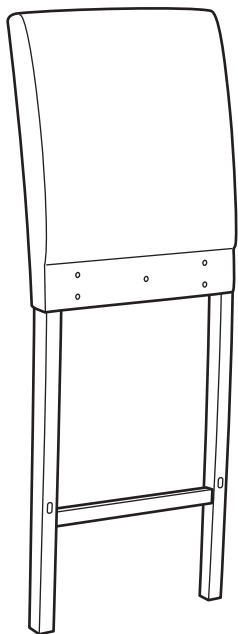

**1** Backrest  
(39.5 x 11 x 100cm)



**2** Front right leg  
(4 x 4 x 59.5cm)



**3** Front left leg  
(4 x 4 x 59.5cm)



**4** Seat  
(41 x 41 x 11.5cm)



**5** Front stretcher  
(34.5 x 2.5 x 3cm)







**6** Side stretcher x 2  
(41 x 2.5 x 3cm)

# Components - Fittings

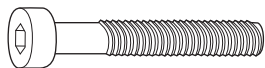
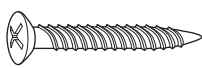
Please check you have all the fittings listed below

**Note:** The quantities below are the correct amount to complete the assembly. In some cases more fittings may be supplied than are required.

<p><b>A</b> </p> <p>M8 x 55mm Bolt x 9</p>	<p><b>B</b> </p> <p>50mm Screw x 6</p>	<p><b>C</b> </p> <p>Spring washer x 9</p>
<p><b>D</b> </p> <p>Flat washer x 9</p>	<p><b>E</b> </p> <p>Allen key x 1</p>	

**Ruler** - Use this ruler to help correctly identify the screws

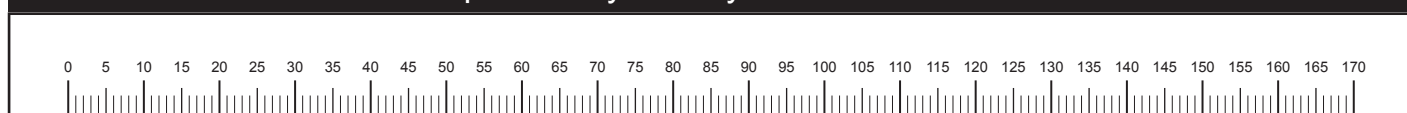

# Assembly Instructions

## Step 1

### Attaching backrest

Place the backrest on a flat protected surface.

Peel off bottom cloth cover of seat by pulling the cloth from the back side of the seat.

Position the seat **4** on the backrest **1** as shown and fix using bolts **A**, spring washers **C** and washers **D**. Tighten bolts using allen key **E**.

**Note:**

Use oval head of allen key on tight angles.

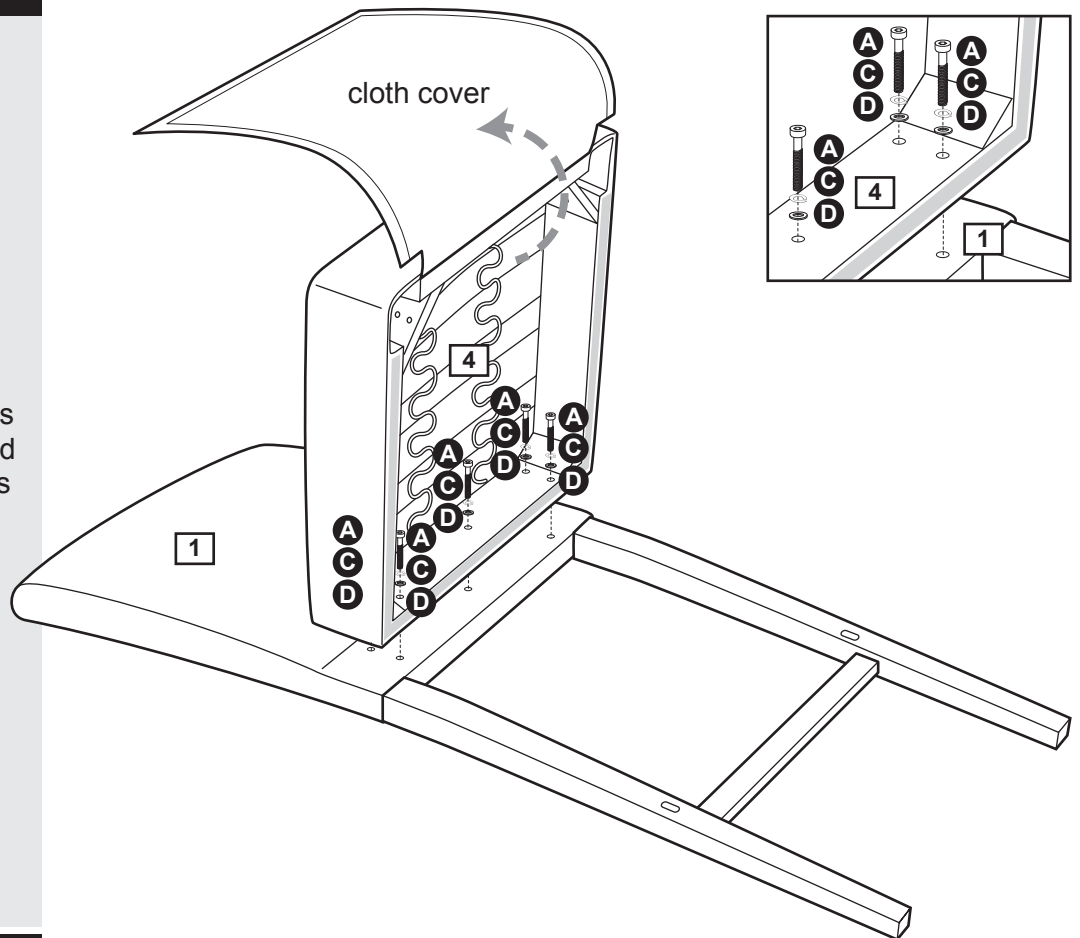

## Step 2

### Attaching side stretchers

Position the side stretchers **6** and insert it into holes on the back rest **1** as shown.



**Note:**

For the correct assembly of the side stretcher **6** to the backrest, the green arrow sticker shall be pointing up.

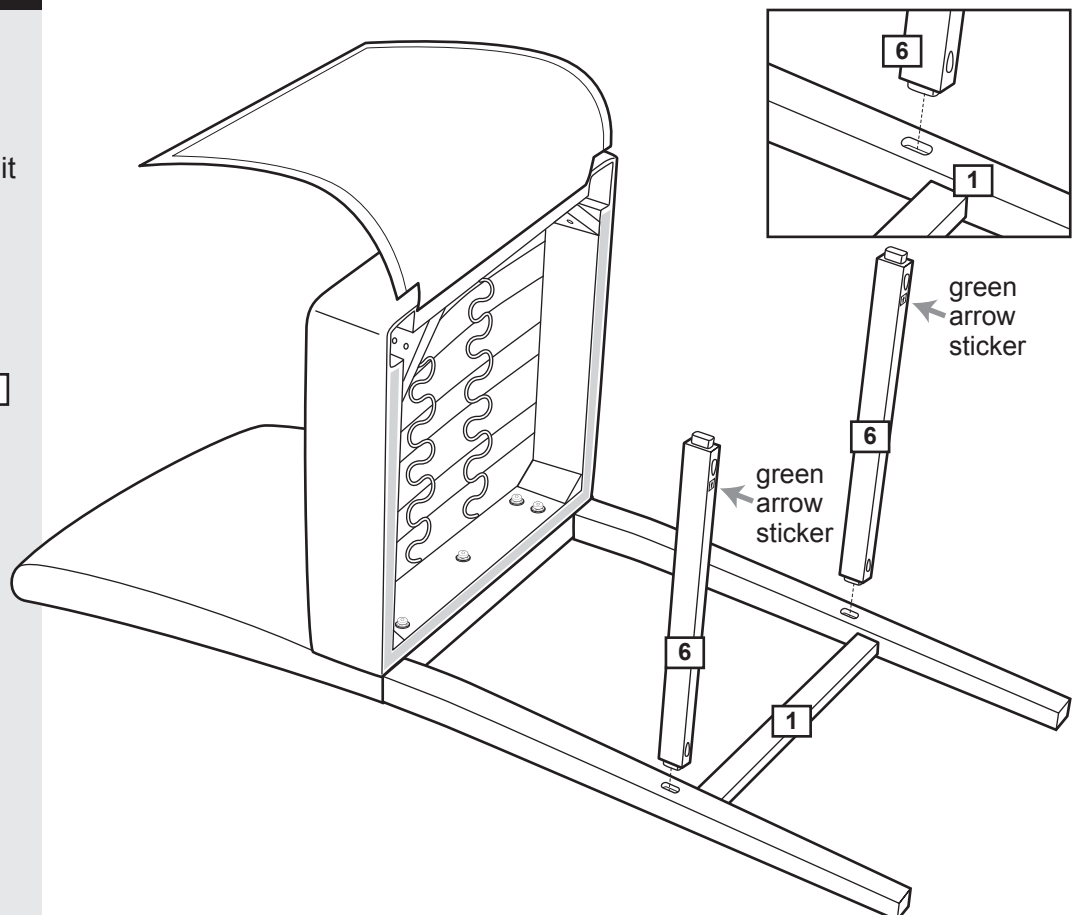

# Assembly Instructions

## Step 3

### Attaching front legs

**a:** Correctly position the front legs **2** & **3** and insert it into holes on the seat **4** as shown.



**Note:** Identify the front right leg **2** which is labeled with 'R' sticker and the front left leg **3** with 'L' sticker.

**b:** Carefully move up the front legs and insert the side stretchers **6** into holes on the front legs as shown.

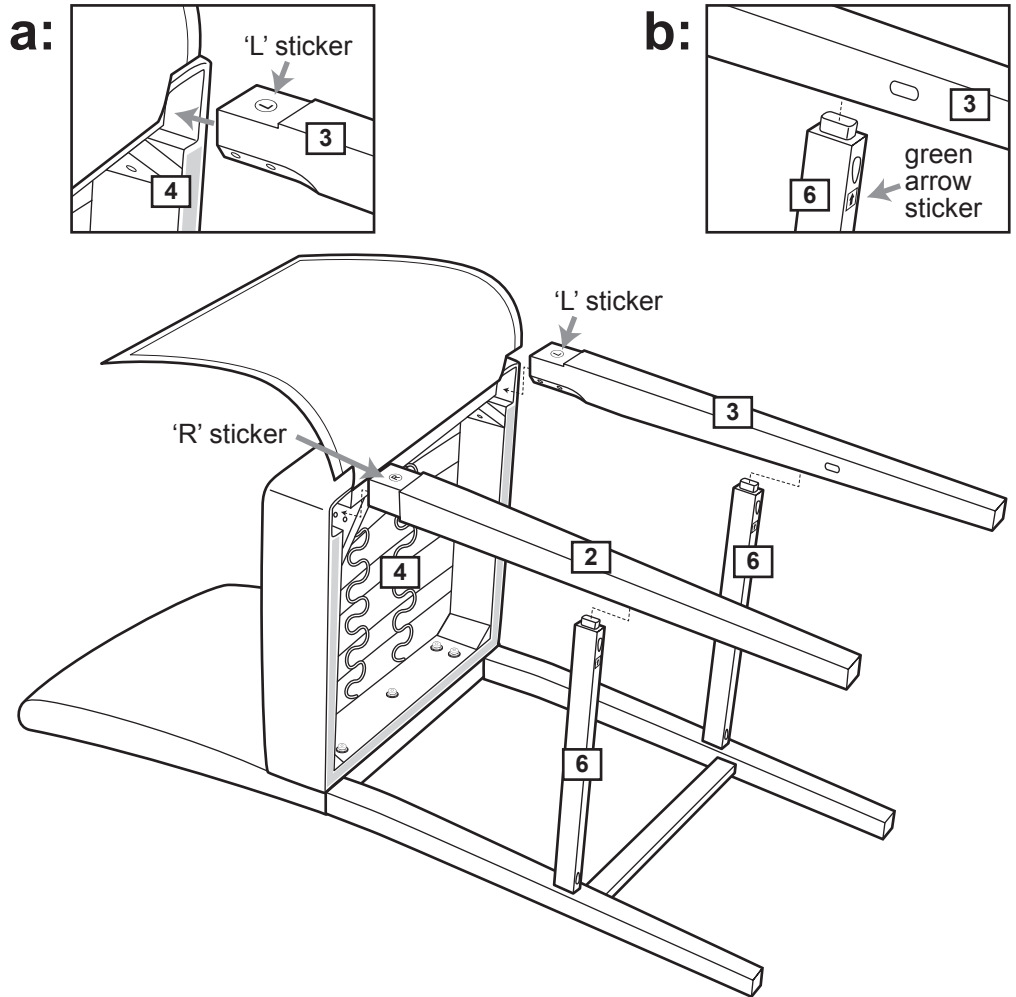

## Step 4

### Attaching front stretcher

Position the front stretcher **5** and carefully insert it into holes on the front legs **2** & **3** as shown.

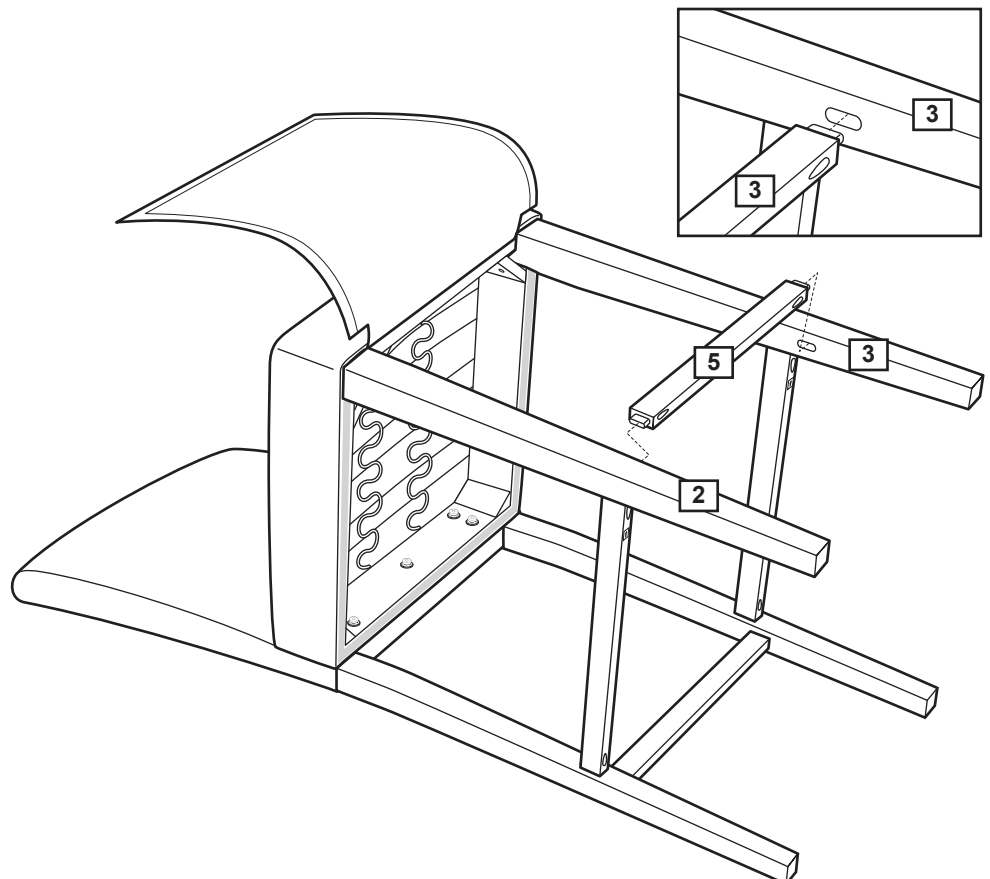

# Assembly Instructions

## Step 5

### Fixing front legs

Secure the front legs **2** & **3** to seat **4** using bolts **A**, spring washer **C** & washers **D**. Tighten bolts using allen key **E**.

#### Note:

Use oval head of allen key on tight angles.

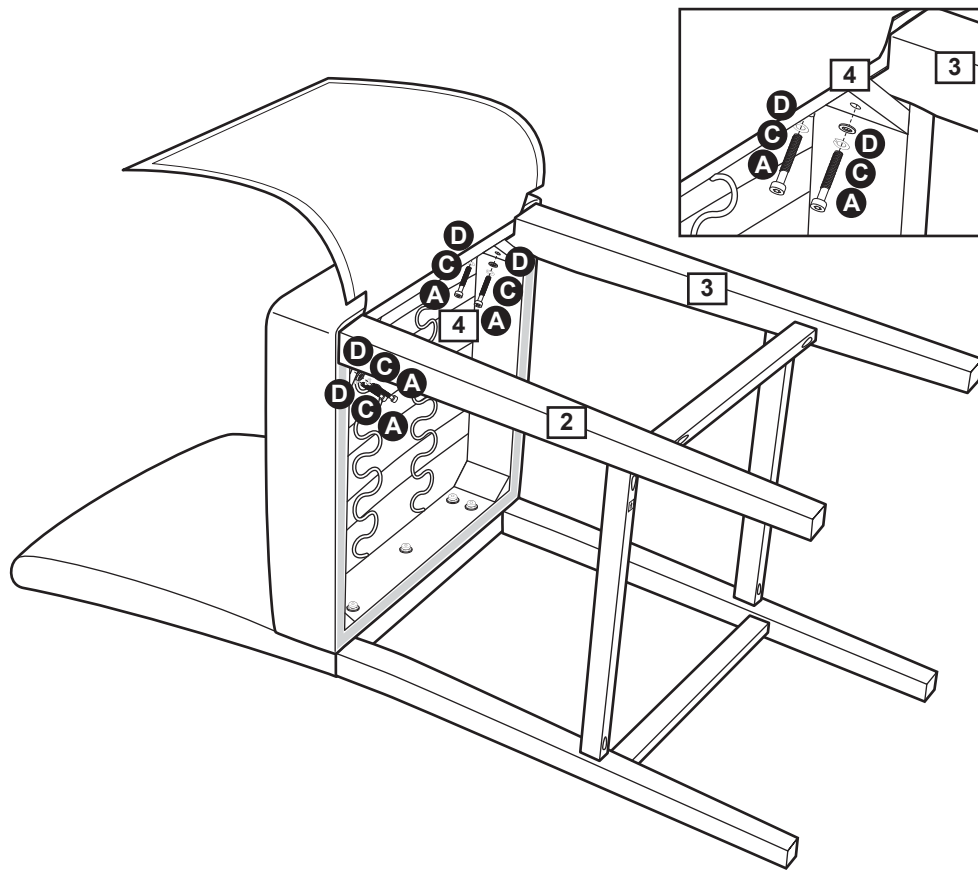

## Step 6

### Fixing stretchers

Carefully turn the bar stool upside down on a raised protected surface.

Secure the stretchers **5** & **6** using screws **B** and tighten using a crosshead screwdriver.

Re-attach the bottom cloth cover as shown and secure with the fasteners attached.

Carefully turn the bar stool upright and place on a flat surface.

**Assembly is complete.**

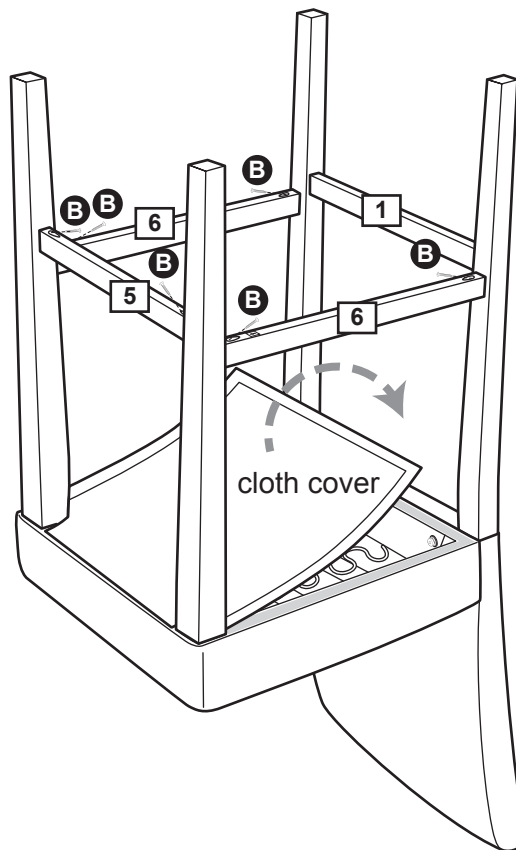
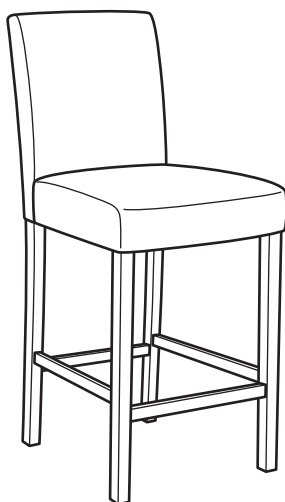
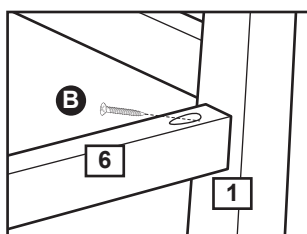

If you need help or have damaged or missing parts, call the **Customer Helpline: 08456 400800**