

Assembly Instructions

Step 3

Note : Stand the chair on a level floor.

a: Tighten all bolts.

Note : Step 3 is essential to prevent the chair from wobbling caused by uneven legs.

b: Sit on the chair to level the legs.

c: After sitting test, re - tighten bolts ,if adjustment is needed.

d: It is highly recommend to re - tighten all the bolts after using the chair for 7 days.

Note : Please keep allen key to re - tighten all bolts when required.

Assembly is complete.

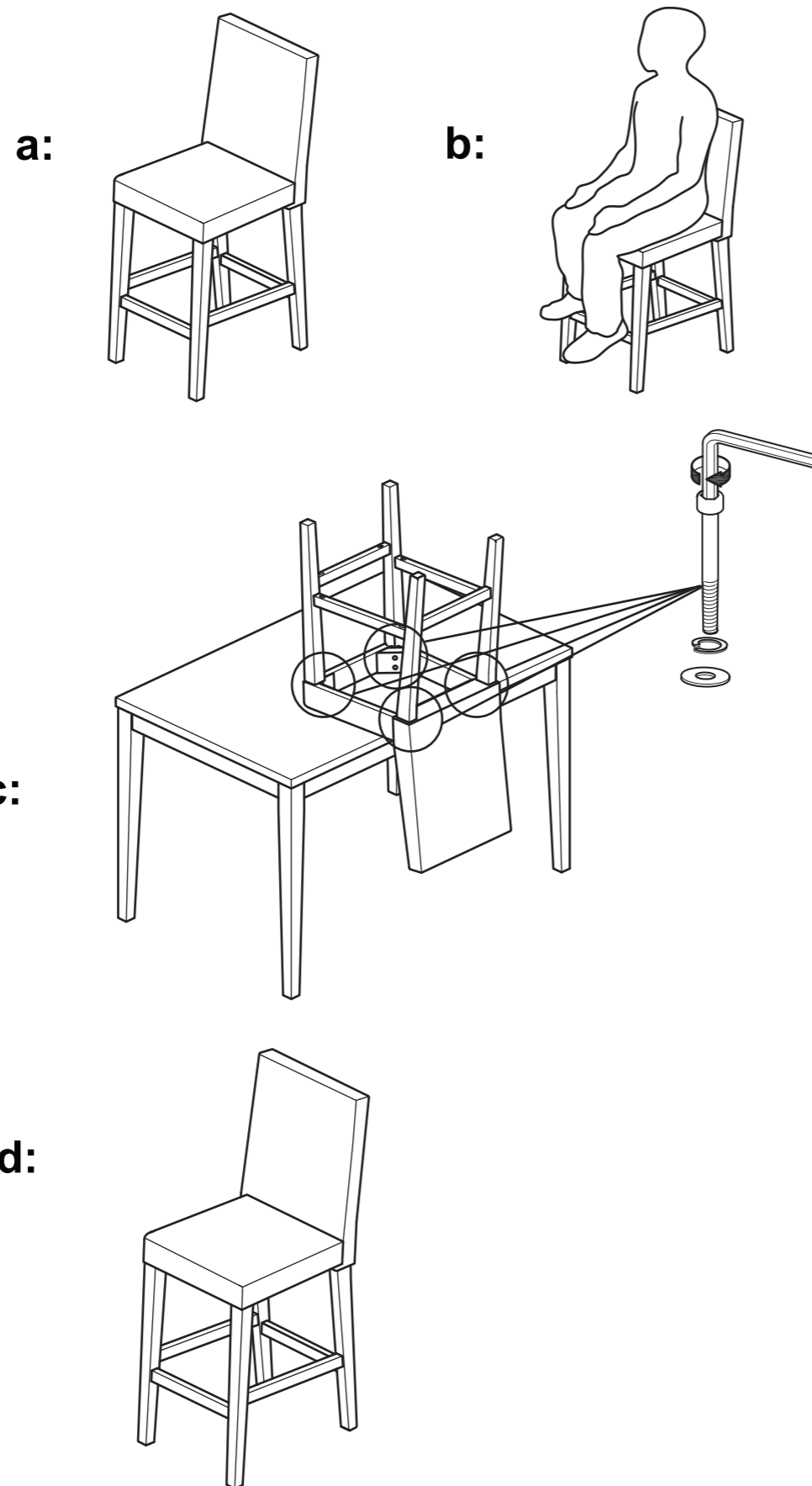

Winslow Bar stool

Assembly Instructions - Please keep for future reference

600/5580

600/5597

600/6280

600/6400

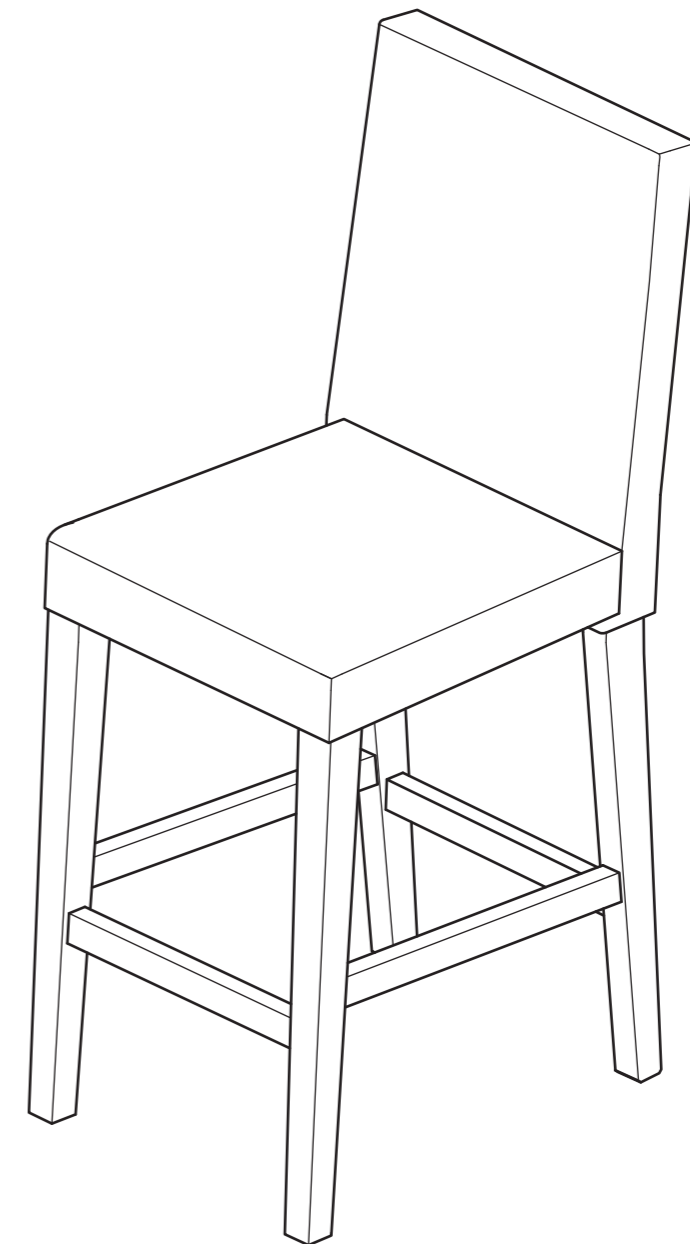

Dimensions

Width - 40cm
Depth - 53cm
Height - 100cm

Important – Please read these instructions fully before starting assembly

If you need help or have damaged or missing parts, call the **Customer Helpline: 08456 400800**

If you need help or have damaged or missing parts, call the **Customer Helpline: 0845 6400800**

! Safety and Care Advice

Important – Please read these instructions fully before starting assembly

- Check you have all the components and tools listed on page 2 and 3.

- Remove all fittings from the plastic bags and separate them into their groups.

- Keep children and animals away from the work area, small parts could choke if swallowed.

- Make sure you have enough space to layout the parts before starting.

- Do not stand or put weight on the product during assembly, this could cause damage.

- Assemble the item as close to its final position (in the same room) as possible.

- Assemble on a soft level surface to avoid damaging the unit or your floor.

- Parts of the assembly will be easier with 2 people.



- We do not recommend the use of power drill/drivers **for inserting screws**, as this could damage the unit. Only use hand screwdrivers.

- Dispose of all packaging carefully and responsibly.

- Maximum safe weight of user: 110 Kgs.

Care and maintenance

- Only clean using a damp cloth and mild detergent, do not use bleach or abrasive cleaners.

- From time to time check that there are no loose screws on this unit.

- This product should not be discarded with household waste. Take to your local authority waste disposal centre.

Assembly Instructions

c: Fit the front stretcher rail **7** to the right leg **3** and left leg **4**.

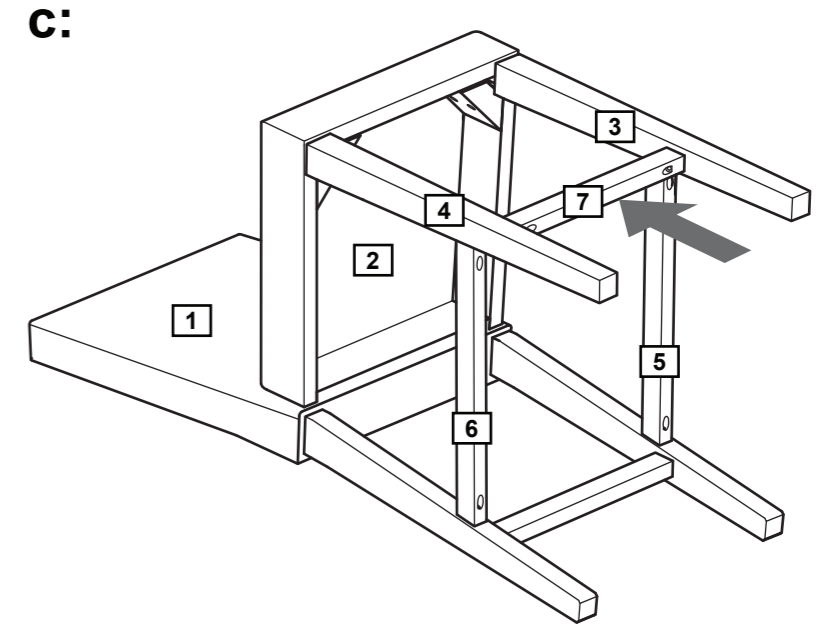

d:

d: Turn over the chair. Screw the screw **E** into the pre - drilled holes on the front stretcher rail **7** and the right side stretcher rail **5** and the left side stretcher rail **7** using screwdriver.

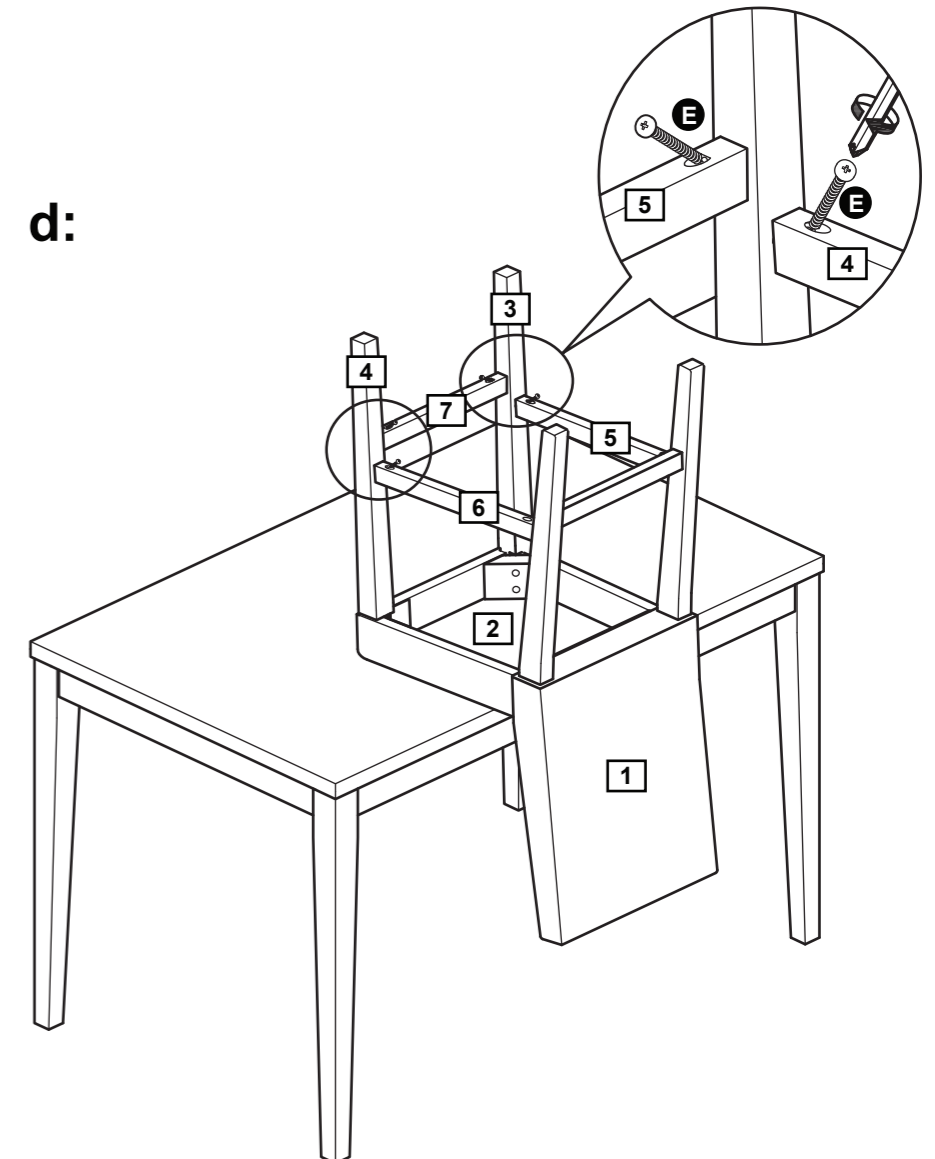

Assembly Instructions

Step 2

a: Attach left legs **4** to front corners of the seat frame. Use bolts **A** with spring washers **B** and washers **C** into each of the 2 holes in the front corners. Tighten bolts with allen key **F**.

Do not fully tighten.

b: Attach right legs **3** to front corners of the seat frame. Use bolts **A** with spring washers **B** and washers **C** into each of the 2 holes in the front corners. Tighten bolts with allen key **F**.

Do not fully tighten.

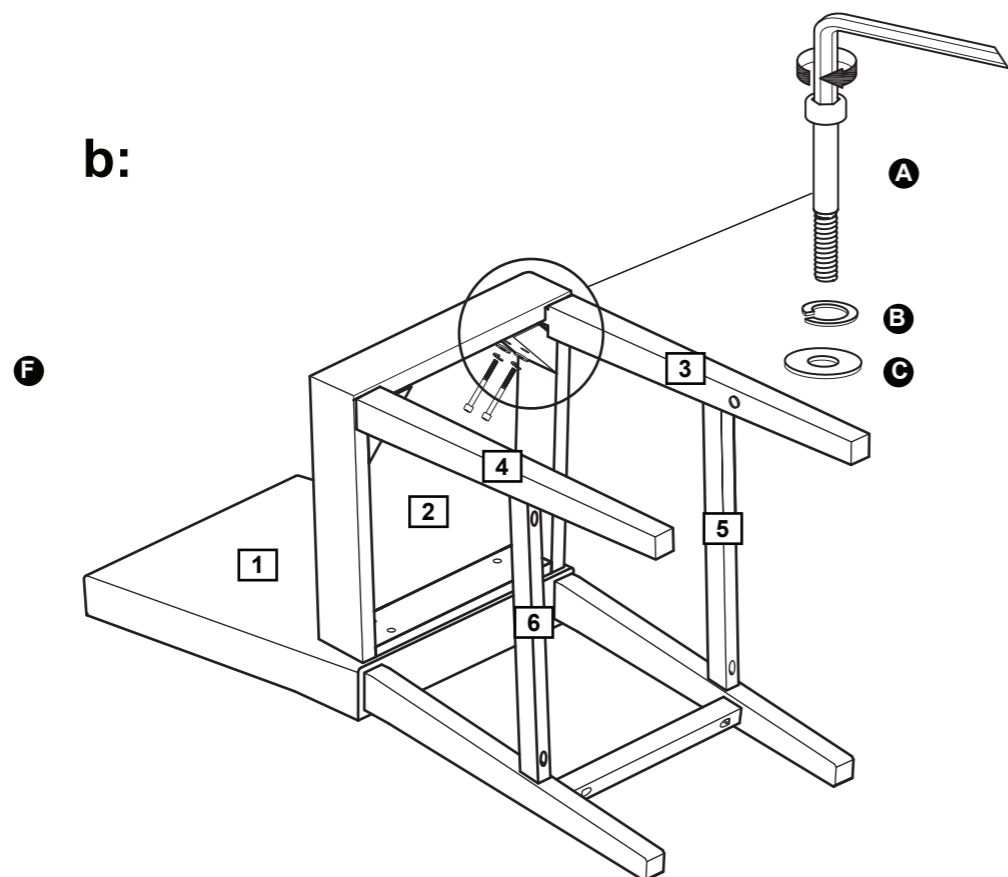
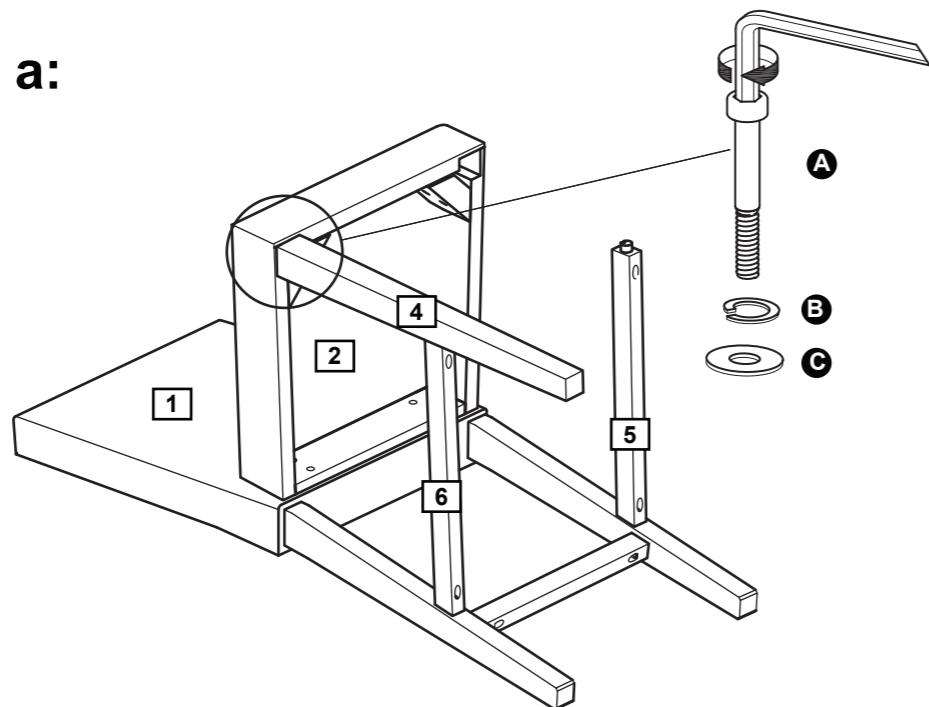

Components - Parts

If you have damaged or missing components, call the **Customer Helpline: 08456 400800**

Please check you have all the parts listed below

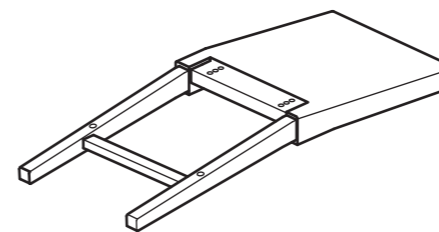

1 Chair back x 1

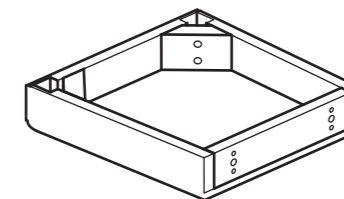

2 Seat x 1

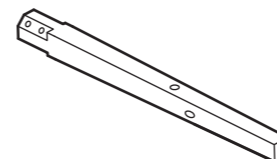

3 Right leg x 1

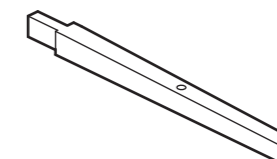

4 Left leg x 1



5 Right side stretcher rail x 1



6 Left side stretcher rail x 1

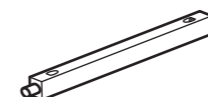





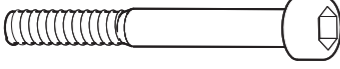

7 Front stretcher rail x 1

Components - Fittings

Please check you have all the fittings listed below

Note: The quantities below are the correct amount to complete the assembly. In some cases more fittings may be supplied than are required.

A 	B 	C 
Bolt x 8	Spring washer x 8	Washer x 8
D 	E 	F 
Wooden dowel x 2	Screw x 6	Allen key x 1

Tools required

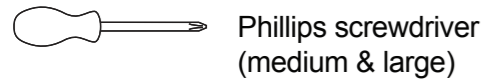

Ruler - Use this ruler to help correctly identify the screws

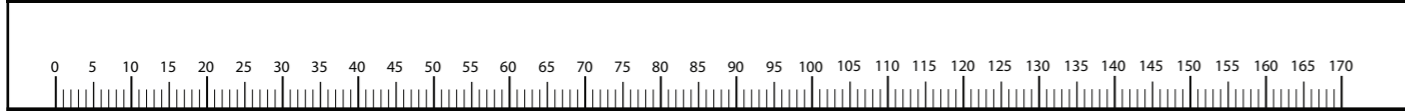

Assembly Instructions

Step 1

a: Insert wooden dowels **D** into each centre hole in the back of the seat **2**.

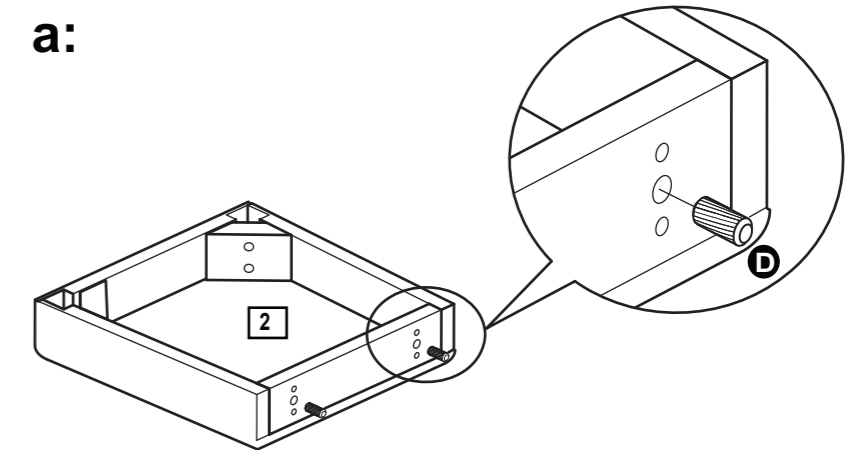

b: Insert bolts **A** with spring washers **B** and washers **C** through the holes at the back of the seat **2** into the chair back **1**. Tighten bolts with allen key **F**.

Do not fully tighten.

Screw the screw **E** into the pre - drilled holes on the right side stretcher rail **5** and the left side stretcher rail **6** using screwdriver.

