

Components

Ⓐ 1 x Left Side Panel

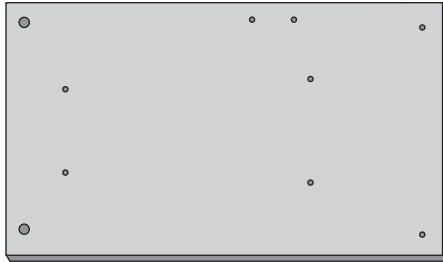

Ⓑ 1 x Right Side Panel

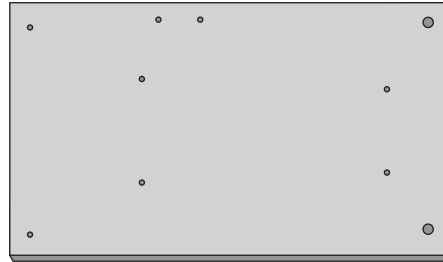

Ⓒ 1 x Table Top



Ⓓ 1 x Keyboard Drawer



Ⓔ 1 x Support

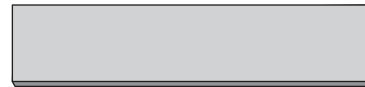

Ⓖ 2 x Front Castor

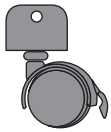

Ⓕ 2 x Castor

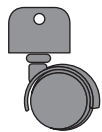

Ⓕ 1 x Shelf



Ⓖ 8 x Plastic Plug



Ⓚ 1 x Right Track



Ⓛ 1 x Left Track



Fittings

Ⓐ 4 x Locking Pin



Ⓑ 8 x Screw



Ⓒ 8 x Screw



Ⓓ 4 x Locking Nut



Ⓔ 4 x Screw



Ⓕ 4 x Nut



Functional Simple Workstation

Simple Assembly Instructions - Please keep for future reference

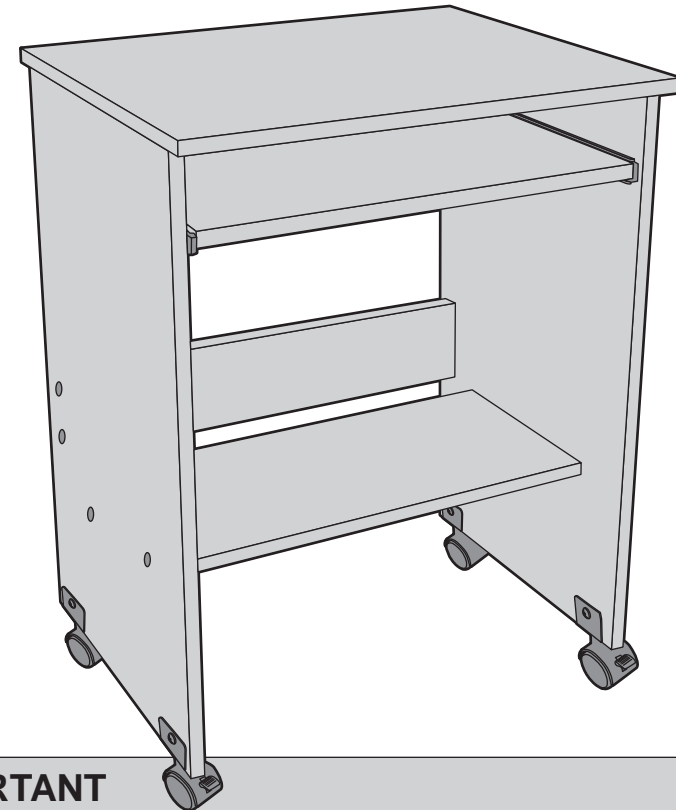

IMPORTANT

1. Read these instructions carefully and familiarise yourself with the procedure before assembling the unit.
2. Check that you have all the component parts following the list on the back cover and familiarise yourself with each part before proceeding.
3. Take all the fittings out of the plastic bag and separate them into their groups.
4. Ensure you have enough space to lay out all the parts before assembly.
5. To avoid scratching it is recommended that you assemble the unit on a soft level surface.

Assembly Instructions

Stage 1 – Fitting the Side Panels

NOTE: It would be useful to ask someone to help you at this stage.

1. Use Screws **C** to fix the Right Track **K** on the Right Side Panel **B**.
See fig. 1.

NOTE: The front part of the Track should be close to the edge of the panel.

2. Follow the same method as in fig. 1 using Screws **C** to fix the Left Track **L** onto the Left Side Panel **A**.
3. Use Screws **B** to fix the Left Side Panel **A** and Right Side Panel **B** onto the Support **E** and Shelf **F**.
See fig. 2.

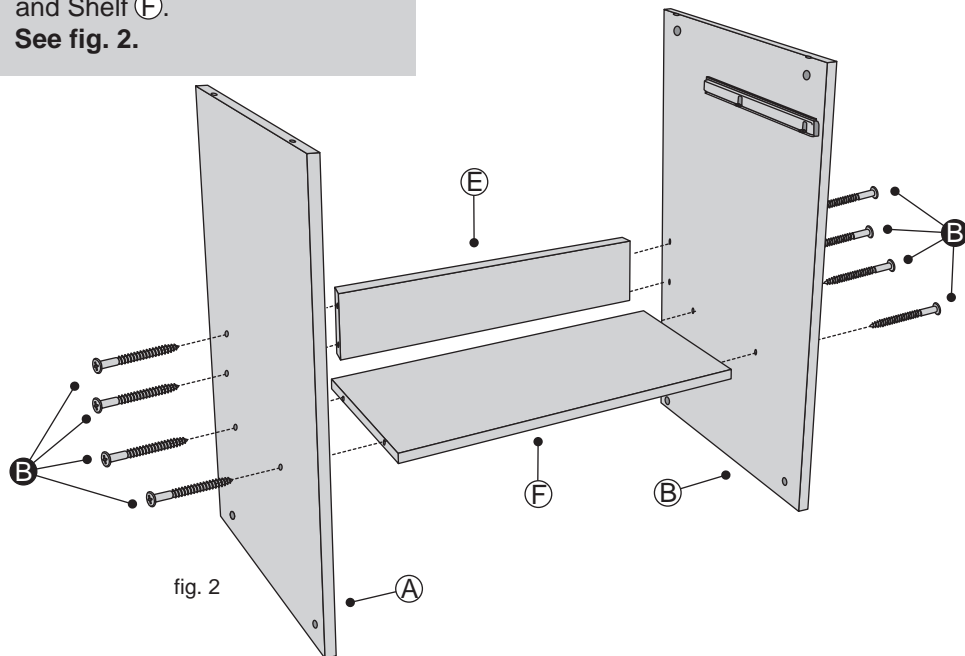
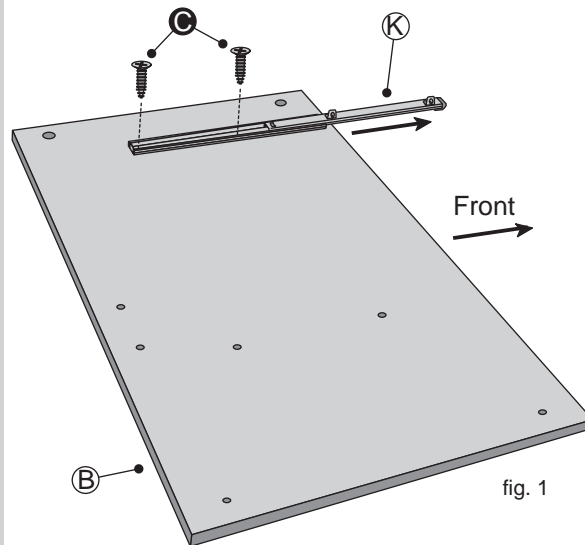

Assembly Instructions

Stage 2 – Fitting the Table Top

NOTE: It would be useful to ask someone to help you at this stage.

1. Screw Locking Pin **A** into the Table Top **C**.
See fig. 3.

2. Carefully locate the Table Top **C** on top of the unit.
See fig. 4.

3. Use Locking Nuts **D** to fix the Table Top **C** onto the unit.
See fig. 4.

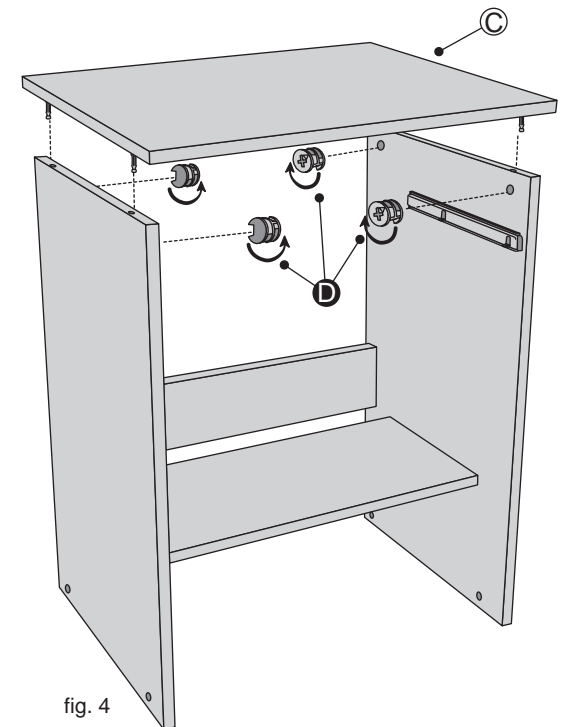
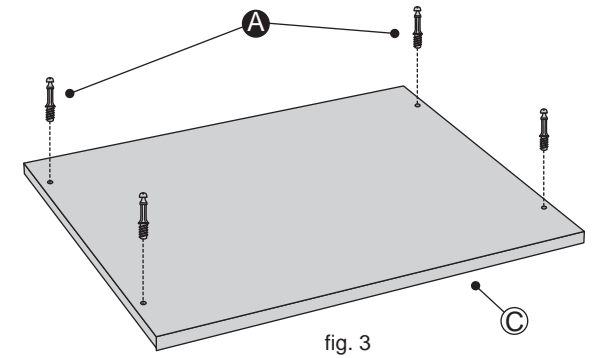

Assembly Instructions

Stage 3 – Fitting the Castors

NOTE: It would be useful to ask someone to help you at this stage.

1. Use Screws **E** and Nuts **F** to fix the Front Castors **G** and Castors **H** onto the unit.
See fig. 5.

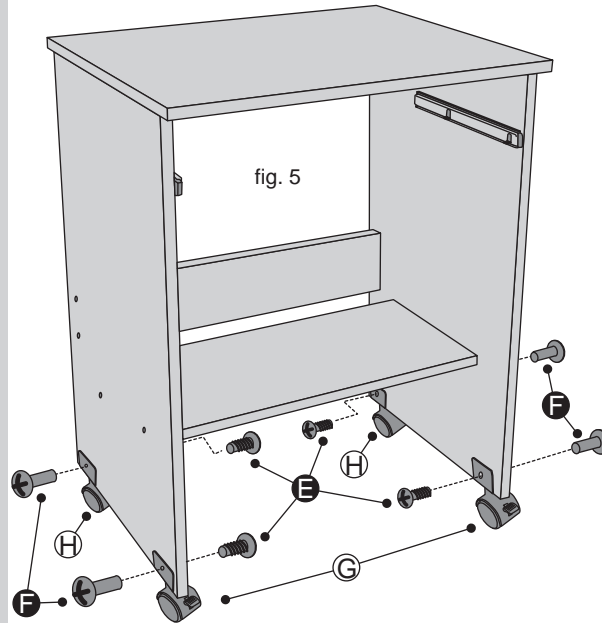

2. Use Screws **C** to fix the Keyboard Drawer **D** onto the Tracks.
See fig. 6.

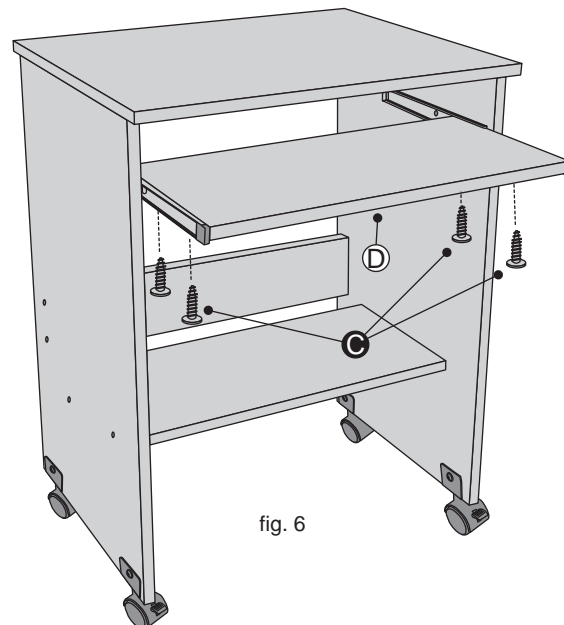

Assembly Instructions

Stage 4 – Finishing the Unit

NOTE: It would be useful to ask someone to help you at this stage.

1. Use Plastic Plugs **J** to cover the Screw Heads.
See fig. 7.

2. Carefully place the unit in the desired location.
See fig. 8.

NOTE: The Front Castors **G** feature a locking arm. We recommend you lock the castors when you have finally positioned the unit in place.

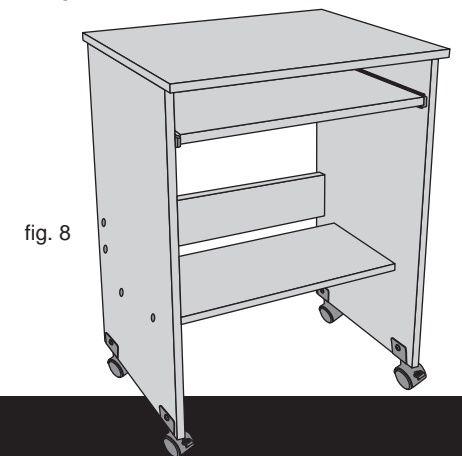
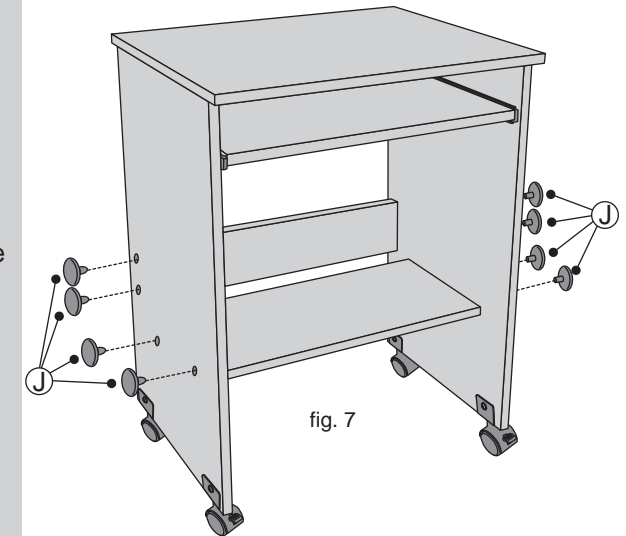

Care and Maintenance

Safety

To avoid any risk of suffocation to animals or children dispose of the plastic bags immediately.

Cleaning

As with all surfaces clean with a damp cloth and mild detergent, do not use bleach or abrasive products.

Fitting

From time to time please ensure there are no loose screws on the product.