

Shark®

Rocket™

OWNER'S GUIDE

HV320UKT

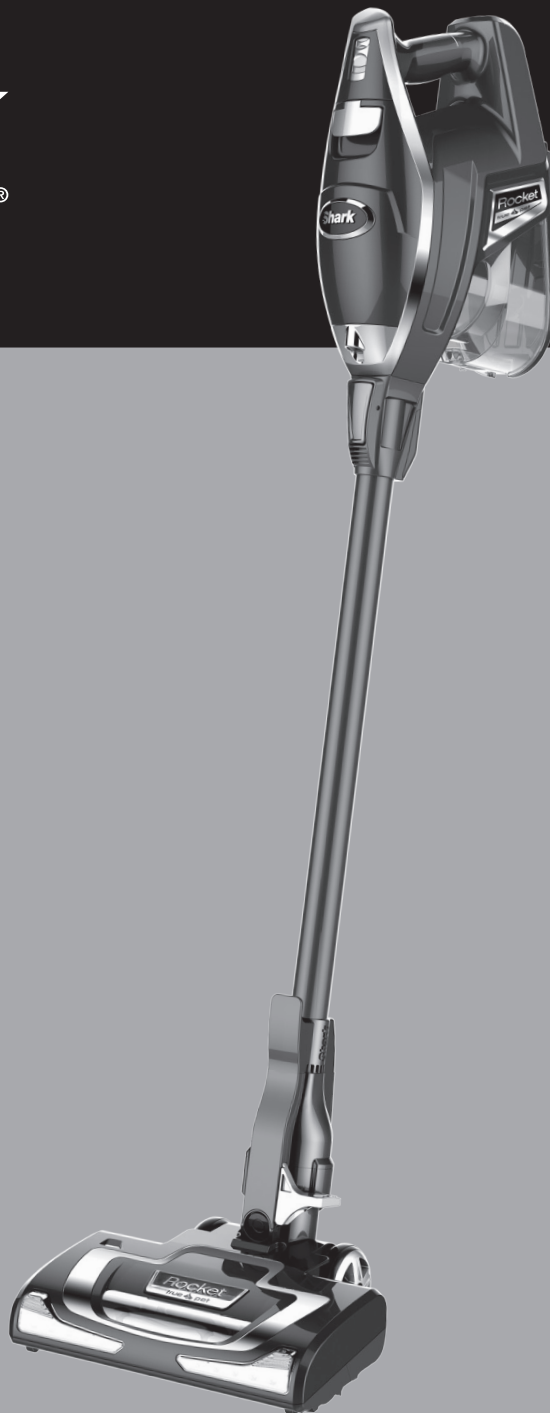

www.sharkclean.eu



0800 862 0453

Thank you for purchasing the Shark® Rocket™ Ultra-Light Upright vacuum cleaner.

This Owner's Guide is designed to help you get a complete understanding of your new vacuum cleaner. Please read it carefully and keep for future reference.

For a list of what is included with this model, refer to inside flap of box.

We are constantly striving to improve our products, therefore the specifications contained herein are subject to change without notice.

If you should have a question about your Shark® Rocket™, please call the Shark® Customer service line at 0800 862 0453.

THANK YOU!

REGISTER YOUR PURCHASE:

 www.sharkclean.eu

 0800 862 0453

RECORD THIS INFORMATION:

Model Number: _____

Date of Purchase (Keep receipt):

TECHNICAL SPECIFICATIONS:

Voltage: 220-240V~, 50Hz

Watts: 500W

RECOMMENDED FILTER CLEANING SCHEDULE:

See the MAINTENANCE section for filter cleaning instructions

Pre-Motor Filter Kit (Foam & Felt): **1080FTV320** Every month

Post-motor filter: **1084FTV320** Every year

This appliance complies with the WEEE-Directive 2012/19/EU on the disposal of electrical and electronic equipment (WEEE).



This marking indicates that this product should not be disposed with other household wastes throughout the EU. To prevent possible harm to the environment or human health from uncontrolled waste disposal, recycle it responsibly to promote the sustainable reuse of material sources. To return your used device, please use the return and collection systems or contact the retailer where this product was purchased. They can take this product for environmental safe recycling.

This appliance complies with the European directives for electromagnetic compatibility (EMC) 2004/108/EC and its revisions, as well as Low Voltage Directive (LVD) 2006/95/EC and its revisions.



IMPORTANT SAFEGUARDS

When using an electrical appliance, basic safety precautions should always be observed, including the following:

WARNING

This appliance is not intended for use by persons with reduced physical, sensory or mental capabilities, or lack of experience and knowledge, unless they have been given supervision or instruction concerning use of the appliance by a person responsible for their safety.

Children shall not use this appliance and close supervision is necessary for any appliance being used near children

CAUTION

THE POWER NOZZLE, WAND, MOTORIZED BRUSH AND HANDLE CONTAIN ELECTRICAL CONNECTIONS:

- These are not serviceable parts.
- Do not use to vacuum any liquids.
- Do not immerse in water when cleaning.
- Prior to use, inspect for damage. Discontinue using if damaged.

TO REDUCE THE RISK OF FIRE, ELECTRIC SHOCK OR INJURY:

- 1 DO NOT use outdoors or on wet surfaces.
- 2 Unplug from electrical outlet when not in use and before servicing.
- 3 DO NOT use with damaged cord or plug.
- 4 DO NOT USE if the appliance is not working, has been dropped, dropped into water, damaged or left outdoors.
- 5 NO SERVICEABLE PARTS. Incorrect re-assembly or repair can cause a risk of electrical shock or injury to persons when the appliance is used. Contact Customer Service.
- 6 DO NOT pull or carry vacuum cleaner by the cord or use the cord as a handle.
- 7 DO NOT unplug by pulling on cord; to unplug, grasp the plug, not the cord.
- 8 DO NOT handle plug or vacuum cleaner with wet hands.
- 9 DO NOT run the vacuum cleaner over the power cord, close a door on the cord or pull cord around sharp corners.
- 10 The use of an extension cord is not recommended.
- 11 DO NOT leave vacuum cleaner unattended when plugged in.
- 12 Keep cord away from heated surfaces.
- 13 Turn off all controls before plugging or unplugging the vacuum cleaner.
- 14 Always turn off the vacuum cleaner before connecting or disconnecting power nozzle.
- 15 Store your vacuum cleaner with the power cord secured around the two cord holders - as shown in the STORAGE section.
- 16 This vacuum does NOT stand upright on its own.

GENERAL USE

- 17 Use only as described in this manual.
- 18 DO NOT put any objects into openings. DO NOT use with any opening blocked; keep free of dust, lint, hair, and anything that may reduce air flow.
- 19 Keep your work area well lit.
- 20 Keep the vacuum cleaner moving over the carpet surface at all times to avoid damaging the carpet fibres.
- 21 DO NOT place vacuum cleaner on unstable surfaces such as chairs or tables.
- 22 DO NOT use without dust cup and/or filters in place.

WAND ATTACHMENTS

- 23 DO NOT use if air flow is restricted; if the air paths, the wand, or the accessories become blocked, turn the vacuum cleaner off. Remove all obstructions before you turn on the unit again.
- 24 Keep the end of the wand and accessory openings away from face and body.
- 25 Keep cleaning tools and wand suction openings away from hair, face, fingers, uncovered feet, or loose clothing.
- 26 Only use manufacturer's recommended attachments.

DUST CUP/FILTERS/ACCESSORIES

Before turning on the vacuum:

- 27 Make sure that all filters are thoroughly dry after routine cleaning.
- 28 Make sure that dust cup and all filters are in place after routine maintenance. Refer to MAINTENANCE section for filter cleaning instructions.
- 29 Make sure accessories are free of blockages.
- 30 Use only manufacturer's recommended accessories and replacement parts.

GENERAL CLEANING

- 31 DO NOT pick up large-sized objects.
- 32 DO NOT pick up hard or sharp objects such as glass, nails, screws or coins that could damage the vacuum cleaner.
- 33 DO NOT pick up smoking or burning objects such as hot coals, cigarette butts, or matches.
- 34 DO NOT pick up flammable or combustible materials such as lighter fluid, petrol, or kerosene or use vacuum in areas where they may be present.
- 35 DO NOT pick up toxic solutions such as chlorine bleach, ammonia, or drain cleaner.
- 36 DO NOT use in an enclosed space where vapours are present from paint, paint thinner, moth-proofing substances, flammable dust or other explosive or toxic materials.
- 37 DO NOT vacuum up any liquids.
- 38 DO NOT immerse vacuum cleaner in water or other liquids.
- 39 DO NOT use outdoors or on wet surfaces; use only on dry surfaces.
- 40 Use extra care when cleaning on stairs.

SAVE THESE INSTRUCTIONS

ASSEMBLY

- 1 Insert the tube into the floor nozzle connector.
- 2 Insert the handheld portion into the top of the tube.
- 3 This vacuum comes with a detachable clip to store up to two accessories on board. Snap the detachable clip onto the tube. Store one accessory on top holder and one accessory on bottom holder.

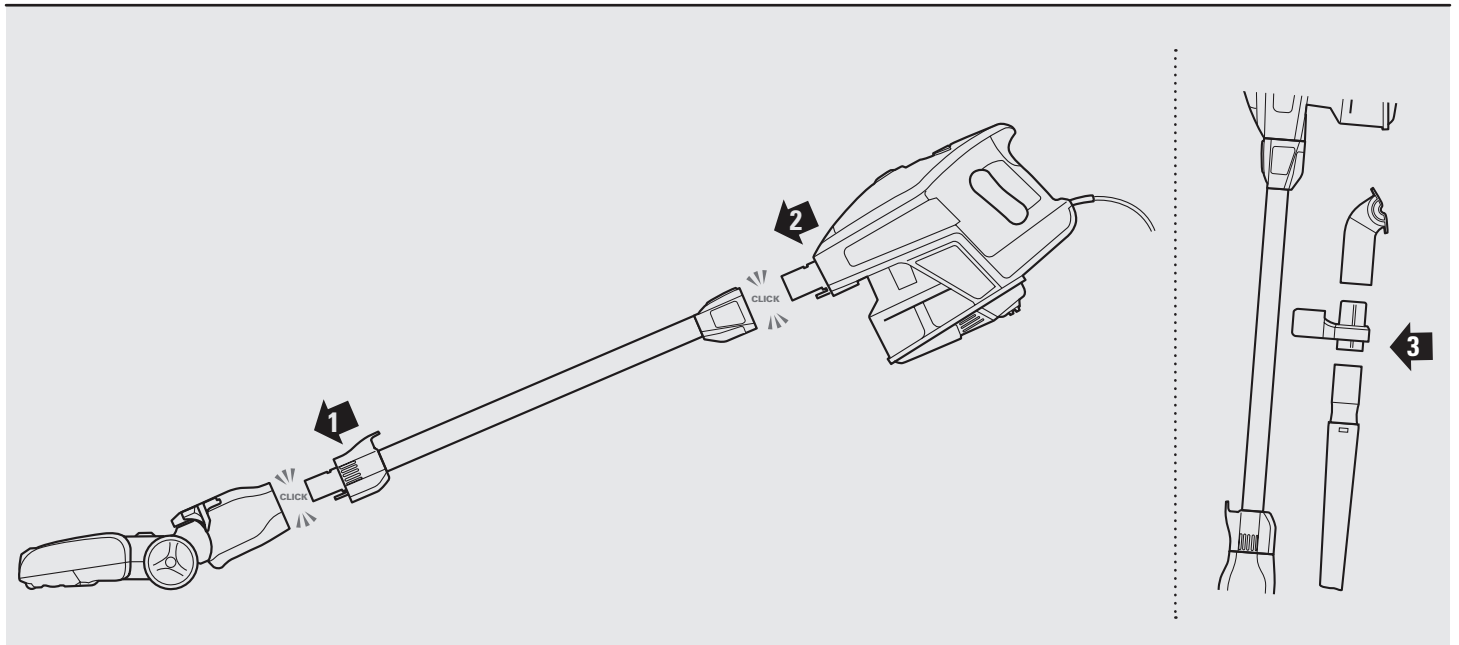

FLOOR CLEANING

This vacuum has a 2-speed POWER slider switch, optimized for bare floor, delicate area rug and carpet cleaning.

The floor nozzle is equipped with headlights that illuminate the floor surface being cleaned. The lights turn on in either speed setting.

- 1 Plug the unit into an outlet. Slide the POWER switch to the first position to clean bare floor surfaces and delicate area rugs. The brush roll will spin slowly to help with debris pick-up.
- 2 Slide the POWER switch to the second position to clean carpets. The brush roll will spin faster to help pick up debris below the surface.

NOTE: This vacuum does NOT stand upright on its own. When taking a break, rest it against a wall or piece of furniture or lay it flat on the floor.

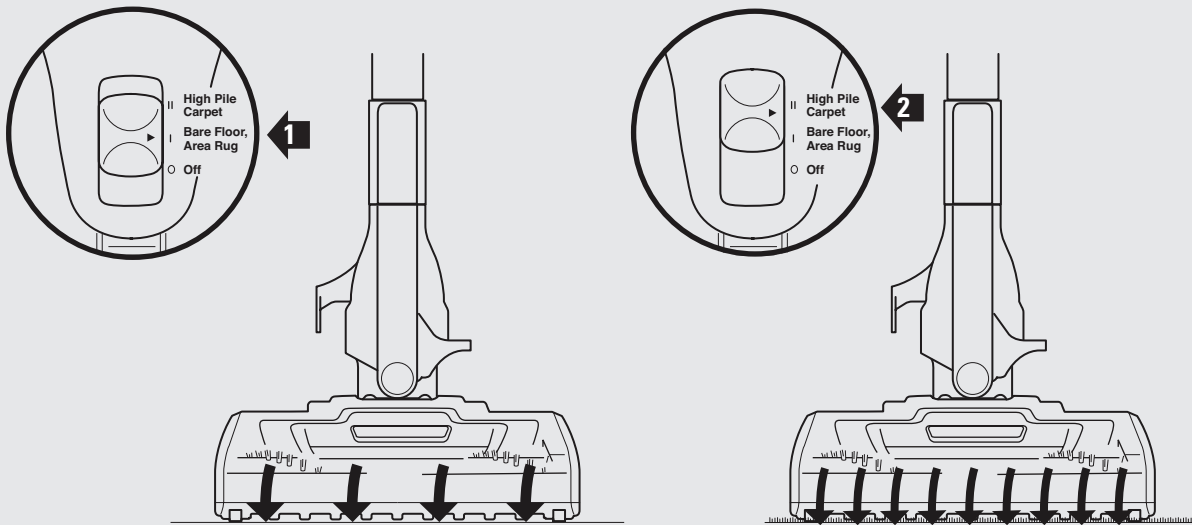

ABOVE FLOOR CLEANING

This vacuum has the reach to clean up above floors or in tight spaces by using the tube. It also has the convenience of a handheld vacuum when using it without the tube and a light to illuminate the cleaning surface.

- 1 Stand the vacuum upright. Step on the foot pedal on the floor nozzle and pull the tube up to disconnect it from the floor nozzle. Attach desired cleaning accessory.
- 2 Press the button on the top of the tube to pull and disconnect it from the handheld portion. Attach desired cleaning accessory. The LED light in the handheld turns on automatically when the power is on.

NOTE: Select cleaning accessories are included with this model. Additional accessories are available for purchase at www.sharkclean.eu or by calling 0800 862 0453.

For a list of what is included with this model, refer to inside flap of box.

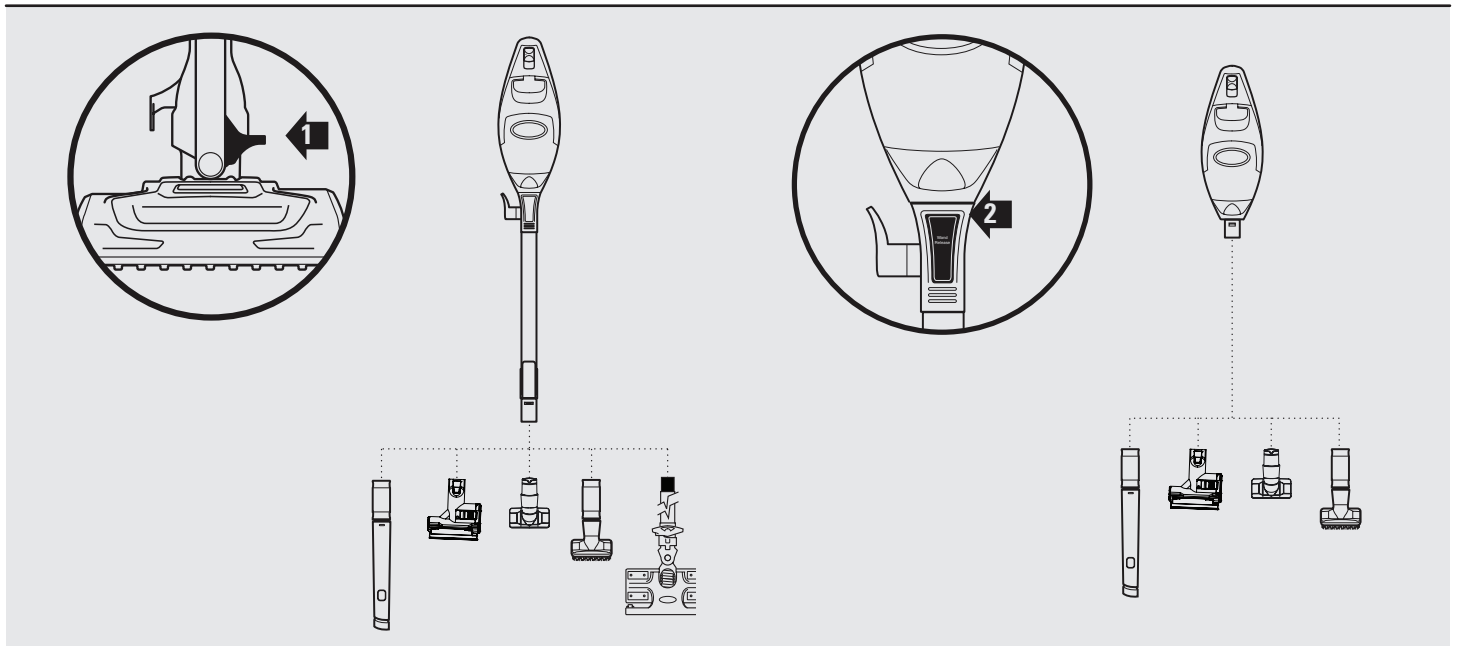

STORAGE

There are two recommended ways to store this vacuum.

OPTION 1: Press the button on the top of the tube and pull to separate it from the handheld portion of the vacuum. There is a hook on the bottom of the handheld portion. Hook it onto the hanger that is on the bottom portion of the tube. Wrap the cord around the two cord hooks. The unit is now ready to be stored.

OPTION 2: Use the wall mount included in the vacuum box. Drill two 5/16" holes and insert the plastic anchors (also included) into the wall. Use a Phillips head screwdriver to screw the wall mount into the plastic anchors. Hook the bottom of the handheld portion of the vacuum onto the hanger portion of the wall mount.

For more detailed instructions, please refer to the instruction sheet included with the wall mount kit.

OPTION 1

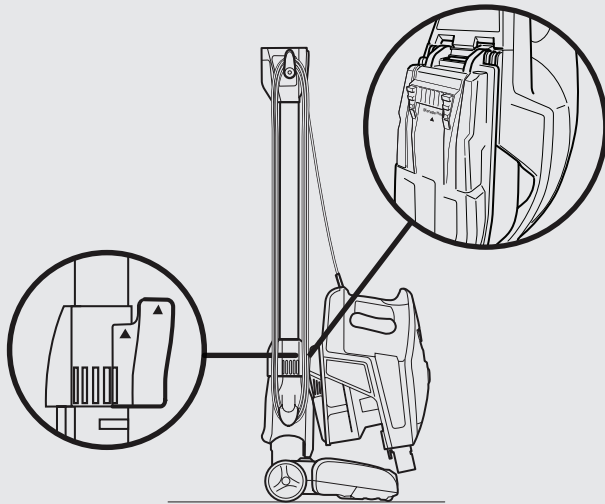

OPTION 2

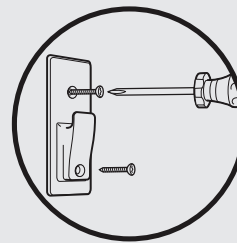

45 cm Crevice Tool

228FFJV300

Extendable with rubberised end flexes to reach tight areas.

ACCESSORIES

NOTE: Select cleaning accessories are included. Others are available for purchase at www.sharkclean.eu or by calling 0800 862 0453.

For a list of what is included with this model, refer to inside flap of box.

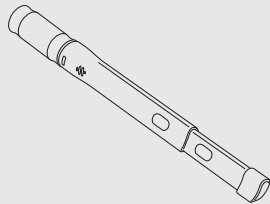

Dusting Brush

229FFJV300

Cleans hard surfaces and upholstery.



Dust-Away™ With Washable Microfibre Pad

XDAV300

Vacuums and dusts bare floors using washable or disposable pads.

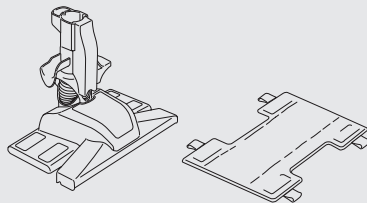

On-Board Upholstery Tool

166FLIHV3



TruePet™ Motorized Brush

3107FV320V220

Picks up pet hair, loose debris, and powerfully deep cleans dander out of upholstery and surfaces.

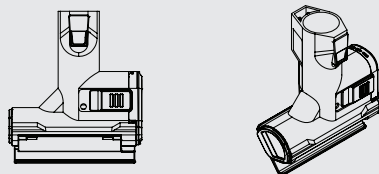

DUST-AWAY™ ATTACHMENT & CLEANING PAD INSTRUCTIONS

MICROFIBRE PAD

- 1 Slip two of the tabs between the suction nozzle and the duster base and attach them to the front fasteners on the base. Then pull the other two tabs tightly around to the back fasteners on the base. For best results, ensure that the pad is flat against the bottom surface and secured tightly.
- 2 Use the Dust-Away™ to clean dry bare floor surfaces. Do not use to clean damp floors or wet / sticky messes. Only use pads provided by Shark®, which are designed to work with the Dust-Away™ attachment.
- 3 Wash the pads separately with warm water either in the washing machine or by hand using liquid detergent.

Do not use bleach or fabric softeners as they may damage or leave a coating that will reduce the cleaning performance of the pads.

Tumble dry low or line dry to extend the life of the microfibre fabric.

For best floor cleaning results, we recommend replacing your microfibre pads every 3-4 months following normal use.

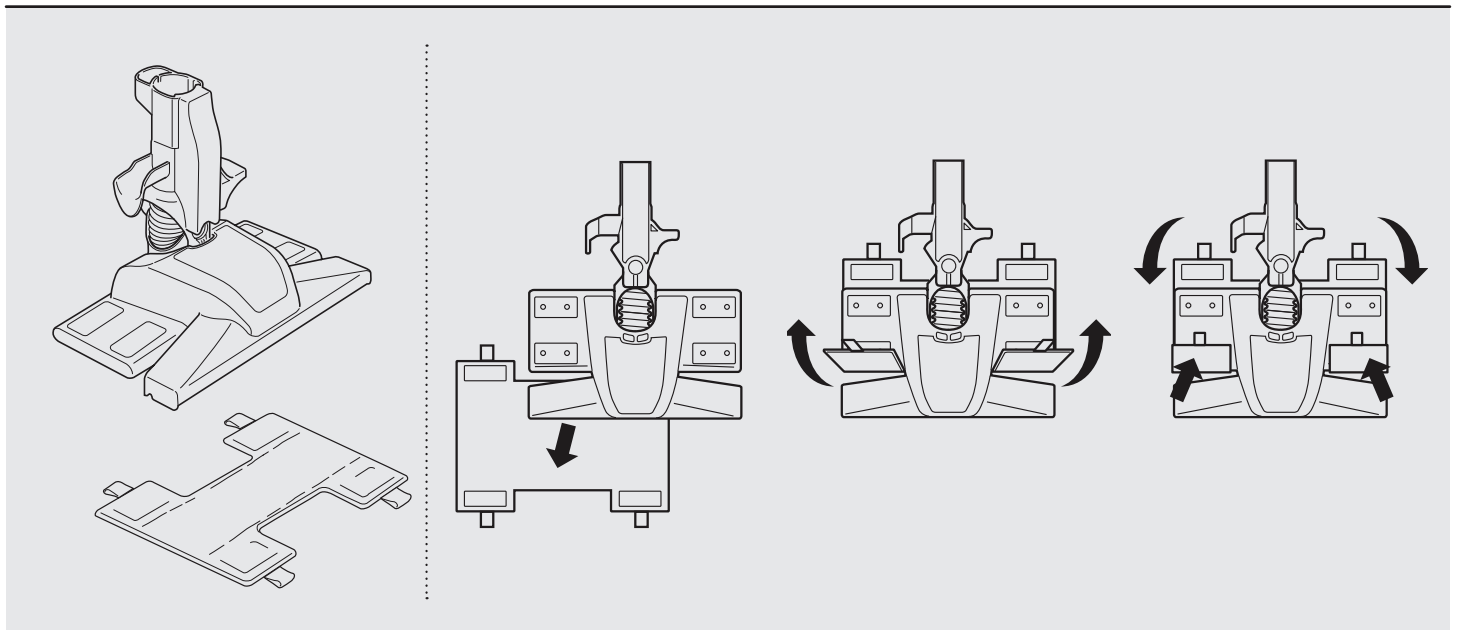

MAINTENANCE

To keep your vacuum's suction power optimal, follow these instructions.

EMPTY THE DUST CUP

- 1 Detach the handheld portion from the rest of the vacuum by pressing the button on the top of the tube to pull it away from the handheld portion.

OR

Separate the dust cup from the vacuum by squeezing the two "dust cup release" buttons on both sides of the base together and pulling it straight out. Rest the vacuum on a piece of furniture or lay it flat on the floor.

- 2 Holding the dust cup over a garbage bag or can, press the empty button on the front of the dust cup. The bottom lid will open, allowing the debris to fall out.
- 3 Clean the dust screen inside the dust cup as required.
- 4 When finished emptying the dust cup, close the bottom lid and insert dust cup back into handheld and you will hear it lock in place.

CLEAN THE FILTERS

- 5 Access the pre-motor filter by lifting the latch on the top of the handheld portion of the vacuum. Remove and rinse the foam and felt filters every month. Hand wash only. Let air dry completely before replacing. Tap loose dirt off filters between washes as needed. Insert the felt filter first and then place the foam filter on top of it.
- 6 Access the post-motor filter under the handle. Remove and rinse once a year. Hand wash only. Let air dry completely before replacing.

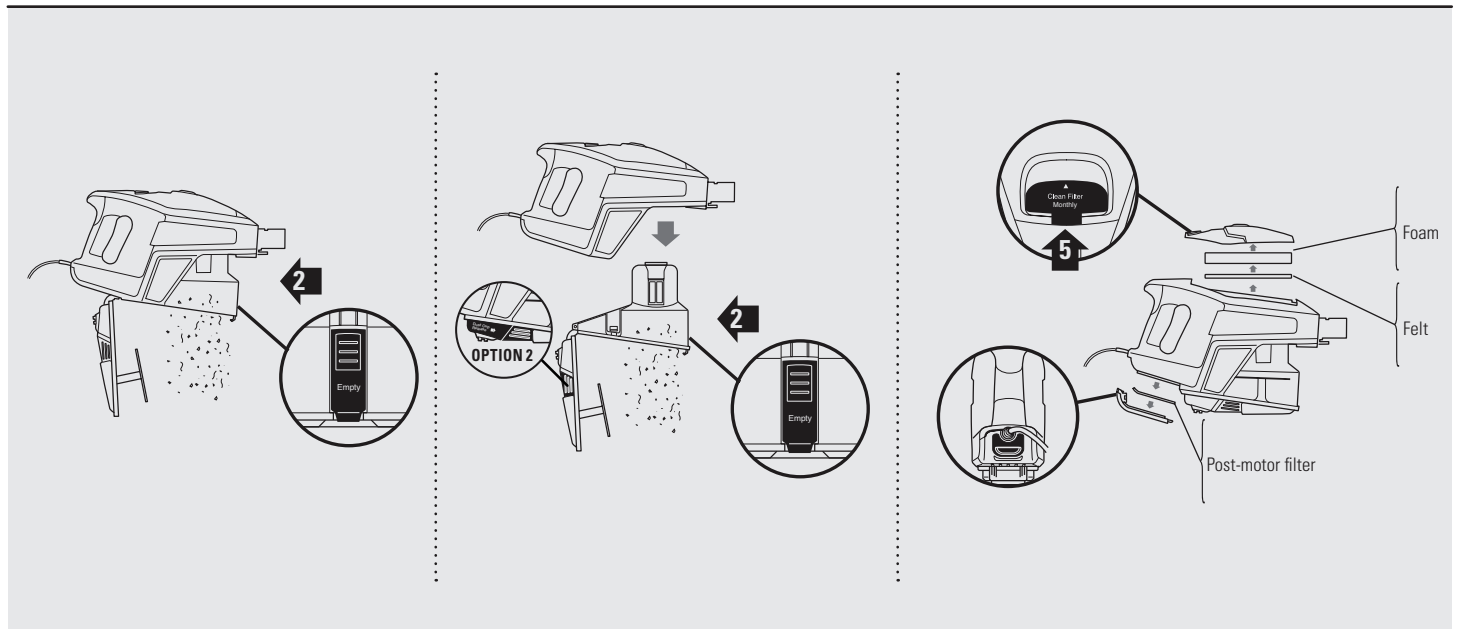

MAINTENANCE

Make sure unit is off and cord unplugged.

CHECK FOR BLOCKAGES

REMOVE AND INSPECT:

1 HANDHELD AND TUBE

- a Remove the tube from the handheld portion and check all dust cup intake openings.
- b Remove the floor nozzle from the tube and check the tube for blockages.

2 BOTTOM OF FLOOR NOZZLE

- c Use a coin to unlock the three locks on the bottom of the floor nozzle.
- d A portion of the base is removable to allow for better access to the brush roll and exposure to the airway. Shine a flashlight from the bottom to check for possible blockage in the airway.
- e Remove any string, carpet fibres or hair that may be wrapped around the brush roll. There is a groove on the brush bar that allows a pair of scissors to cut across it to loosen up the debris.
- f To reassemble, replace base by lining it up along the front of the nozzle. Push down to snap into place. Lock the three locks.

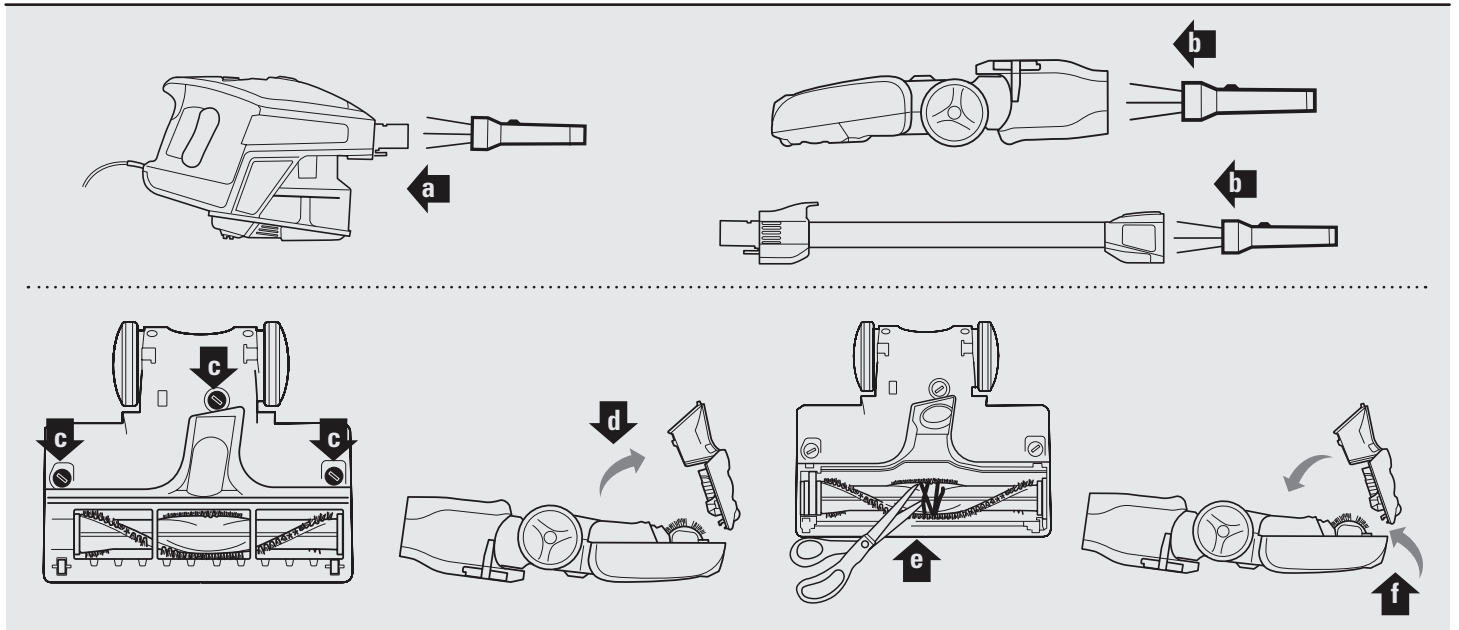

TROUBLE- SHOOTING GUIDE

Vacuum is not picking up dirt. No suction or light suction.

- Check filters to see if they need cleaning. Follow instructions for rinsing and drying the filters before re-inserting back into the vacuum.
- Dust cup may be full; empty dust cup.
- Check tube, tube connections, nozzles and accessories for blockages; clear blockages if required.
- Remove any string, carpet fibers or hair that may be wrapped around the brush roll.

Vacuum lifts area rugs

- Suction is powerful. Take care when vacuuming area rugs or rugs with delicately sewn edges.
- Turn off the unit to disengage the brush roll and restart with the POWER button.

Brush roll does not spin

- If brush roll indicator light on the floor nozzle turns red, the brush roll has stopped spinning. Immediately turn off and unplug vacuum, disconnect the nozzle and remove blockage before reconnecting and turning vacuum back on.
- If brush roll indicator light on the floor nozzle is green, the blockage has been successfully cleared. If the light is still red, please contact customer service at 0800 862 0453.

Vacuum turns off on its own

- This vacuum cleaner is equipped with a motor protective thermostat. If for some reason your vacuum overheats, the thermostat will automatically turn the unit off. Should this occur, perform the following steps to restart the motor thermostat:
 1. Turn the unit off.
 2. Unplug the vacuum.
 3. Empty the dust cup and clean filters.
 4. Check for blockages in tube, accessories and inlet openings.
 5. Allow the unit to cool for a minimum of 30 minutes.
 6. Plug in the vacuum.
 7. Restart the unit by turning the power on.





WARRANTY TERMS AND CONDITIONS

These conditions set out the conditions and scope of our guarantee. They do not affect the agreement between you and your retailer, your statutory rights or any other obligations of your retailer.

IMPORTANT: Please keep your receipt at all times. It will be used for verification purposes if you need to use your extended guarantee, and your guarantee may be invalidated if you cannot produce your receipt.

Term of the free Shark guarantee

We understand that your new Shark machine needs to operate properly for as long as possible. The following guarantees reflect our confidence in the quality of your product and its manufacturing:

- One year unconditional guarantee of all Shark machines against all defects of workmanship and materials
- An additional extended 4 years guarantee for all Shark Vacuum cleaners.
- A free parts and labour guarantee for every Shark machine. You can find online support at www.sharkclean.eu/uk, or you can contact our customer service helpline and speak to a Shark representative directly. Our helpline is open Monday to Friday from 9.00am to 6.00pm and is free to call.

Both the one year and the extended 4 years guarantees cover your machine from the date of purchase as stated on your receipt or delivery note.

Shark understands that in some circumstances, you may want to repair your Shark machine after the relevant guarantee has elapsed. In such circumstances, please contact our free phone customer service help line on 0800 862 0453 and enquire about our out-of-warranty program.

Scope of the free Shark guarantee

In addition to your legal rights as a consumer, the free Shark guarantee covers repair or replacement of your Shark machine (at Shark's discretion), including all parts and labour.

The free Shark guarantee does not cover the following:

- Blockages – For details of how to unblock your vacuum cleaner, please refer to the Operating Manual.
- Normal wear and tear including to the brush bar, fuse, belt, batteries etc.
- Accidental damage, faults caused by negligent use or care, misuse, neglect, careless operation or any other handling of the vacuum cleaner which does not comply with the Shark Operating Manual supplied with your machine.
- Use of the vacuum cleaner other than for normal domestic household purposes.
- Use of parts not assembled or installed in accordance with the operating instructions.
- Use of parts and accessories which are not Shark Genuine Components.
- Faulty installation (unless the installation was carried out by Shark).
- Repairs and alterations (unless carried out by Shark or its agents)

Extending your Shark guarantee

To benefit from the extended Shark guarantee, within 28 days of making your purchase you must register your guarantee online at www.sharkclean.eu/uk/register-guarantee. To register your guarantee, you will need your serial number (which can be found on the machine rating label) and the date you purchase the machine (as stated on your receipt or delivery note). When you submit your details online, we will confirm that we have received them instantly.

Once you have registered your guarantee, we may contact you using the details you have provided if needed. You can also opt to receive tips and advice on how to get the best out of your Shark machine and updates about our new Shark products and technology.

Genuine Shark parts and accessories

The same engineers who developed your Shark machine have developed our range of Shark spares and accessories.

The guarantee is invalidated if you use spare parts that are not Euro-Pro spare parts or are not approved by Euro-Pro.

For all Shark machines our full range of Shark spares and replacement parts can be found at www.sharkclean.eu/uk/parts, and our full range of Shark accessories can be found at www.sharkclean.eu/uk/accessories.



Shark®

Euro-Pro Europe Limited
15 Mariner Court
Calder Park
Wakefield
WF4 3FL

Freephone 0800 862 0453
www.sharkclean.eu



HV320UKT_40_IB_150622_1

© 2015 Euro-Pro Operating LLC

Printed in China

Illustrations may differ from actual product.