

10 Tier Rolling Shoe Rack

Assembly Instructions - Please keep for future reference

390/9665

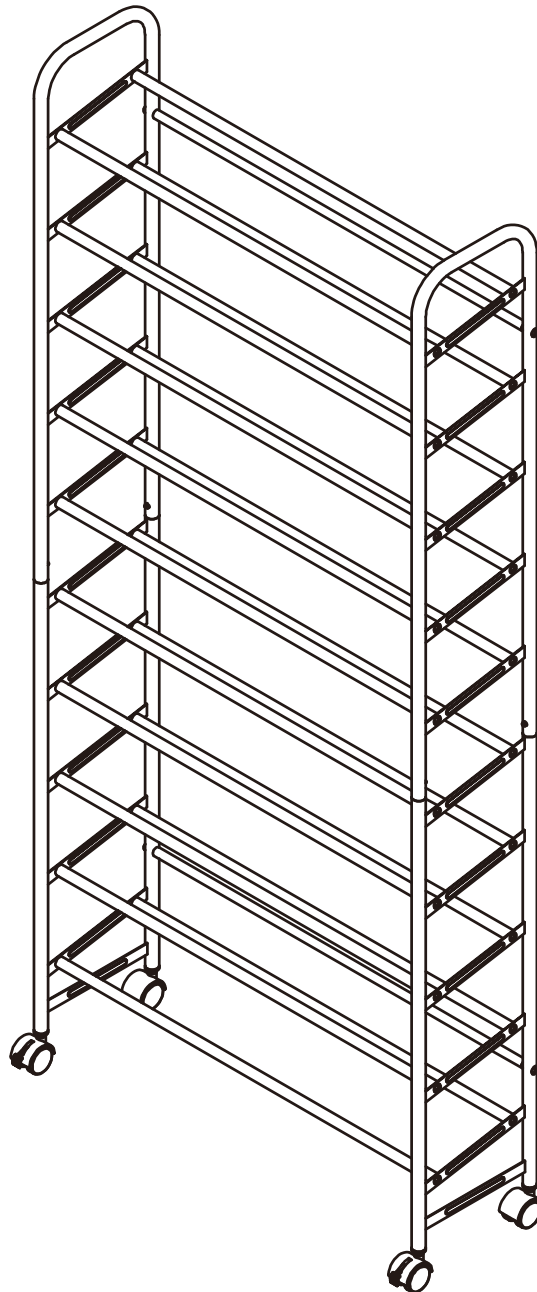

Dimensions

Width - 73cm

Depth - 22.5cm

Height - 163.5cm

Important – Please read these instructions fully before starting assembly

If you need help or have damaged or missing parts, call the **Customer Helpline: 03456 400800**



Safety and Care Advice

Important – Please read these instructions fully before starting assembly

- Check you have all the components and tools listed on the following pages.
- Remove all fittings from the plastic bags and separate them into their groups.
- Keep children and animals away from the work area, small parts could choke if swallowed.
- Make sure you have enough space to layout the parts before starting.

- During assembly do not stand or put weight on the product, this could cause damage.
- Assemble the item as close to its final position (in the same room) as possible.
- Assemble on a soft level surface to avoid damaging the unit or your floor.
- Parts of the assembly will be easier with 2 people.



- To reduce the likelihood of damaging your product please ensure that your power drill is set on a low torque setting.

Care and maintenance

- Only clean using a damp cloth and mild detergent, do not use bleach or abrasive cleaners.
- From time to time check that there are no loose screws on this unit.
- This product should not be discarded with household waste. Take to your local authority waste disposal centre.

Handy Hints

- Assemble all parts and bolts loosely during assembly, only once the product is complete should you fully tighten the bolts
- Regularly check and ensure that all bolts and fittings are tightened properly.

Components - Parts

If you have damaged or missing components, call the **Customer Helpline: 03456 400800**

Please check you have all the fittings listed below

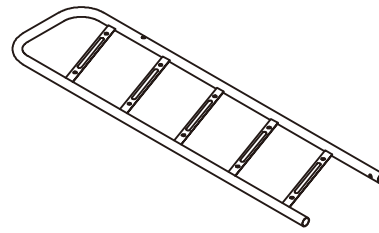
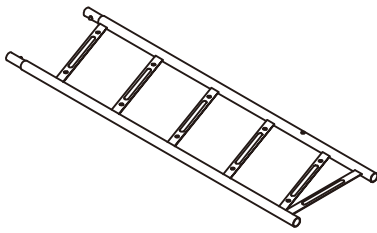

1 Lower Side Frame x 2

2 Upper Side Frame x 2

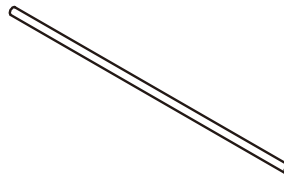
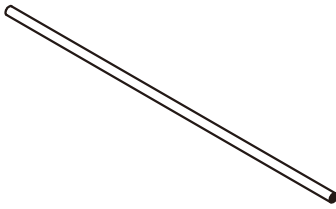

3 710 mm Black Coated Steel Tube x 20

4 694 mm Black Coated Steel Tube x 2

Components - Fittings

Please check you have all the fittings listed below

Note: The quantities below are the correct amount to complete the assembly. In some cases more fittings may be supplied than are required.

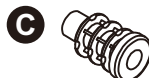

18 mm Screw x 40

28 mm Screw x 4

Plastic Insert x 4

Regular Castor x 2

Castor with stopper x 2

Tools required

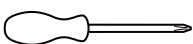

Screwdriver

Assembly Instructions

Step 1

Connect **3** 710 mm Black Coated Steel Tube with **2** Upper Side Frame using **A** Screw.

Connect **4** 694 mm Black Coated Steel Tube with **2** Upper Side Frame using **B** 28mm Screw.
See fig 1.

Now finished the upper part of shoe rack.

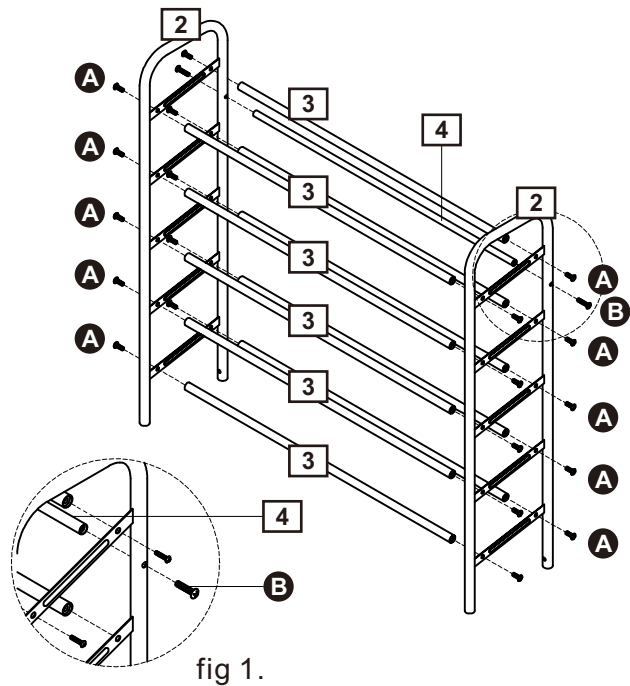

Step 2

Repeat above processes for the lower part of shoe rack.

Connect **4** 694 mm Black Coated Steel Tube with **1** Lower Side Frame.
See Fig 2.

Insert **C** Plastic Insert to **1** Lower Side Fram and insert **D** Regular Castors and **E** Castors with Stoppers respectively.

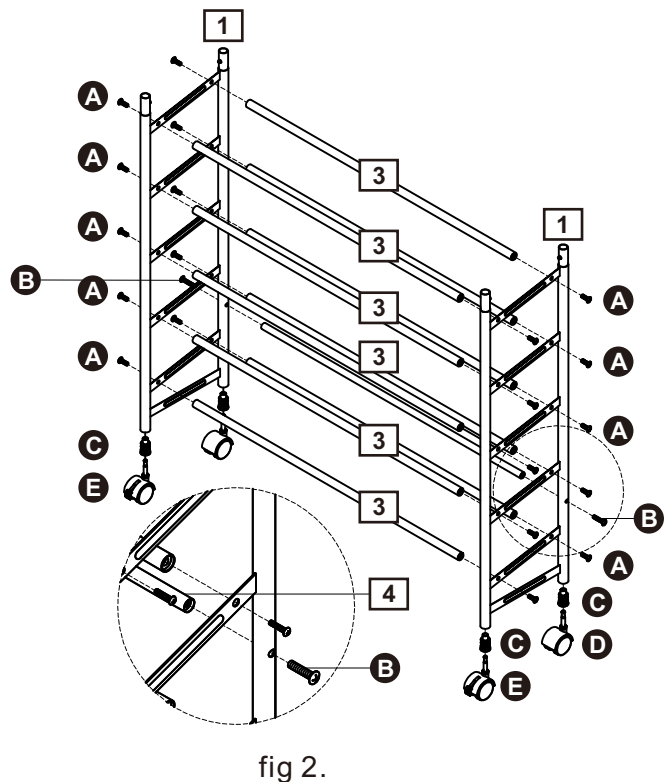

Assembly Instructions

Step 3

Connect the upper part of shoe rack with lower part of shoe rack together.

Note: It would be useful to ask someone to help you at this stage.

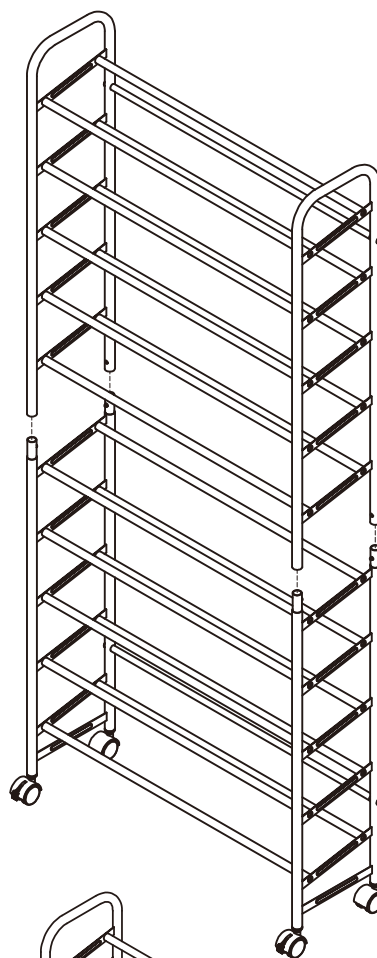

Assembly is complete.

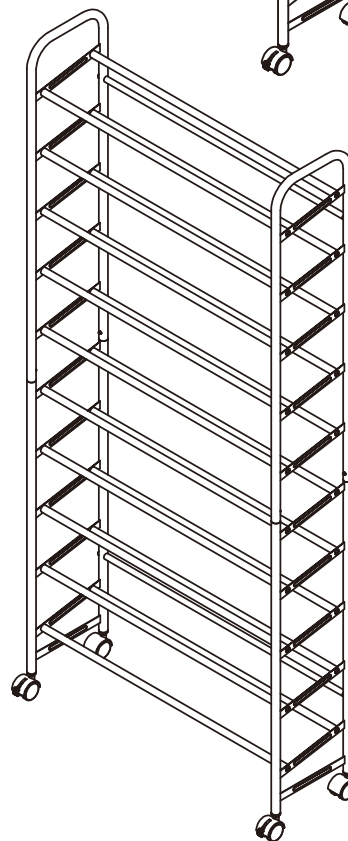

If you need help or have damaged or missing parts, call the **Customer Helpline: 03456 400800**