

Breville®

Turn **on** your creativity™



HotCup™ water dispenser
boils water in seconds

PRODUCT SAFETY

READ CAREFULLY AND KEEP FOR FUTURE REFERENCE

This appliance can be used by children aged from 8 years and above and persons with reduced physical, sensory or mental capabilities or lack of experience and knowledge if they have been given supervision or instruction concerning use of the appliance in a safe way and understand the hazards involved. Children shall not play with the appliance. Cleaning and user maintenance shall not be made by children unless they are older than 8 and supervised. Keep the appliance and its cord out of the reach of children aged less than 8 years.

Never use a power base other than the one supplied with the appliance.

Never fill the kettle above the MAX marking. If the kettle is overfilled, boiling water may be ejected.

If the supply cord is damaged, it must be replaced by the manufacturer, its service agent or similarly qualified persons in order to avoid a hazard.

- ⚠ This appliance generates heat during use. Adequate precaution must be taken to prevent the risk of burns, scalds, fires or other damage to persons or property caused by touching the exterior whilst in use or during cooling.
- ⚠ Never use this appliance for anything other than its intended use. This appliance is for household use only. Do not use this appliance outdoors.
- ⚠ Always ensure that hands are dry before handling the plug or switching on the appliance.
- ⚠ Always use the appliance on a stable, secure, dry and level surface.
- ⚠ Never use a power base other than the one supplied with the appliance.
- ⚠ This appliance must not be placed on or near any potentially hot surfaces (such as a gas or electric hob).
- ⚠ Do not use the appliance if it has been dropped, if there are any visible signs of damage or if it is leaking.
- ⚠ Ensure the appliance is switched off and unplugged from the supply socket after use and before cleaning.
- ⚠ Always allow the appliance to cool before cleaning or storing.
- ⚠ Never immerse any part of the appliance or power cord and plug in water or any other liquid.
- ⚠ Never let the power cord hang over the edge of a work top, touch hot surfaces or become knotted, trapped or pinched.
- ⚠ Never leave the appliance unattended when in use.
- ⚠ Beware of steam coming from the spout or lid especially during refilling. Never open the lid during the boiling cycle.
- ⚠ Never fill the appliance when it is positioned on the power base.
- ⚠ Never use the appliance without sufficient water in it for it to operate correctly.
- ⚠ Never allow the appliance to boil dry.
- ⚠ Always operate the appliance with a cup or suitable container placed below the dispensing nozzle.

IDENTIFYING THE PARTS

1. Removeable drip tray

No mess, just lift it off the power base and rinse under the tap. Holds over 1 cup of water before it needs emptying.

2. Removable stainless steel drip tray cover

3. Dispensing nozzle

4. Stop button

Press to immediately stop the boil sequence or to stop water that is being dispensed.

5. Start button

Press to start the boil sequence.

6. Dispensing control

This control allows you to select the amount of water dispensed by your HotCup™. Move it towards ▼ for less water or ■ for more water.

7. Lid flap release button

Press to open the lid flap only and fill the water tank.

8. Lid

9. Water chamber

10. Power base

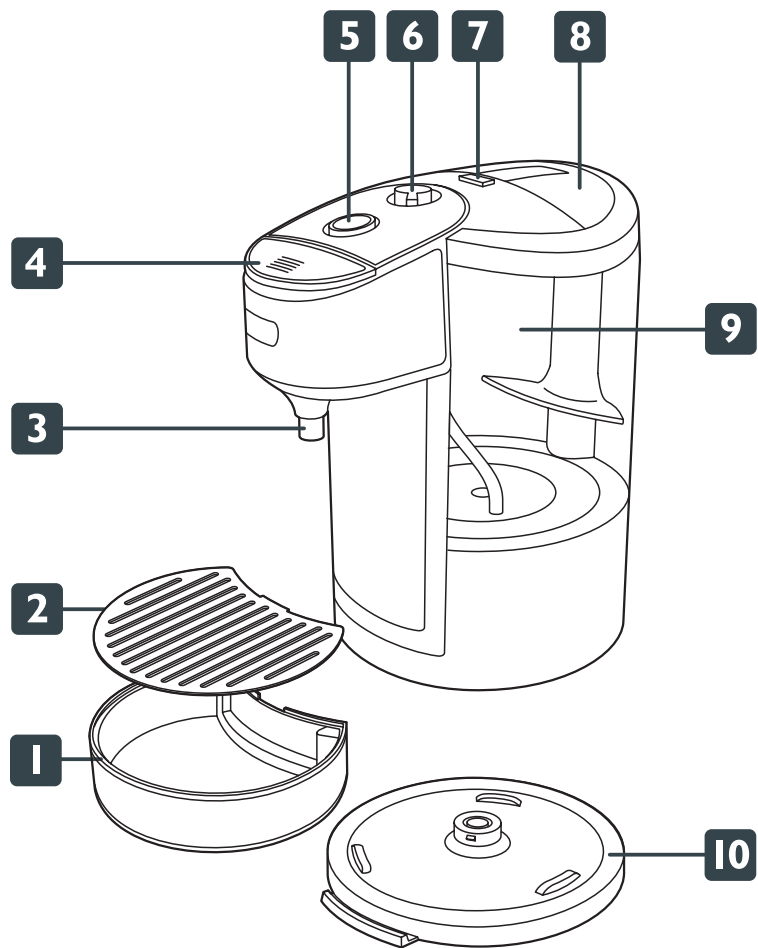



USING YOUR HOTCUP™

Before using your HotCup™ for the first time

- Remove your HotCup™ carefully from the box. Remove any packaging and promotional material and position your HotCup™ on a dry, level, secure work surface away from the edge.
- Follow the instructions below and discard the first full tank of water. Repeat once more. This will remove any residues that may remain from the manufacturing process.

Using your HotCup™

▲ Always position your HotCup™ in such a way that the start button cannot be accidentally operated, especially by children. As you use your HotCup™, a certain portion of the water boiled will be transferred back to the water reservoir. This will mean the water reservoir may become hot. Always use care when handling your HotCup™.

1. Press the lid flap release button to open the lid.
2. Fill the water chamber from your cold tap up to the MAX mark.
3. Close the lid and press the stop button. This will make sure that your HotCup™ will not immediately start a boil cycle when you place it onto the power base.
4. Connect your HotCup™ to a mains supply socket.
5. Place a suitable cup or container with a tea bag, coffee, sugar, etc. below the dispensing nozzle. Never operate your HotCup™ without a cup or suitable container placed below the dispensing nozzle. Adjust the dispensing control to the required setting. The control adjusts the quantity of boiling water dispensed by your HotCup™. For smaller cups like teacups, set the control towards the  setting; for larger cups like coffee mugs, set the control towards the  setting. If you are not sure which setting to use, it's best to use a lower setting until you gain experience using your HotCup™.
6. Press the start button. The body will light up blue and your HotCup™ will start to boil.
7. The selected quantity of boiling water will be dispensed into the cup. Your HotCup™ is now ready to use again. If, after just having boiled, the start button doesn't operate, simply wait a few seconds before trying it again.

Stopping your HotCup™

If you have started the boil procedure and then decide you want to stop your HotCup™ for any reason, simply press the stop button. You can also stop water that is being dispensed by pressing the stop button. The boiled water will be safely transferred back into the water reservoir.

1



2

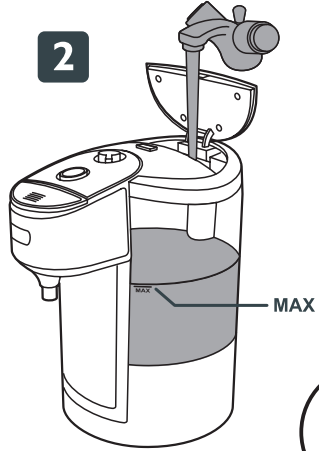

3

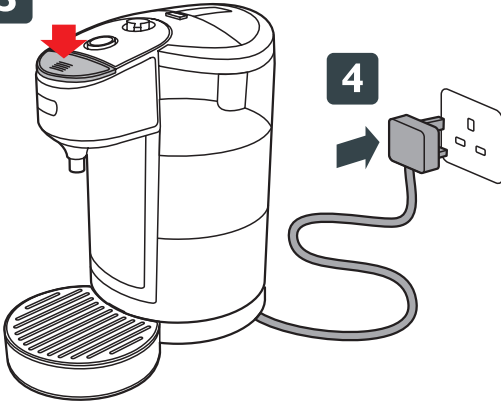

4

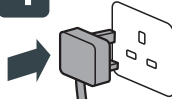

5

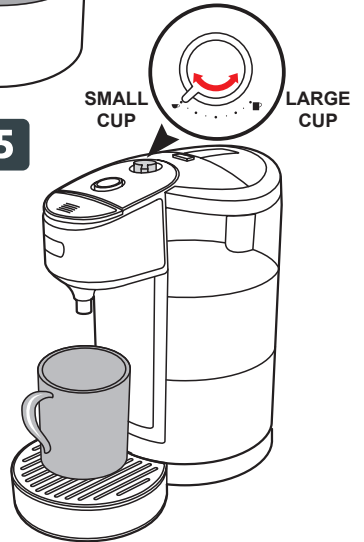

6

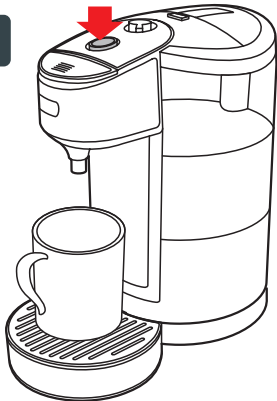

7



EMPTYING AND CLEANING

⚠ Always switch off and unplug your HotCup™ and allow it to completely cool before cleaning. Never immerse the base unit, power cord or plug in water or any other liquid. Do not use harsh abrasives, chemicals or oven cleaners.

Emptying your HotCup™

1. Fill your HotCup™ with a quantity of water that just covers the perforated stainless steel element cover.
2. Place a suitable cup or container below the dispensing nozzle. Set the dispense control to the **■** setting.
3. Press the start button.
4. After the water has been dispensed, empty the cup and replace it back under the dispensing nozzle.
5. Press the start button again.
6. Discard the water.

Your HotCup™ is now empty.

If your HotCup™ will not be used for an extended period (e.g. if you are on holiday), we recommend that you first empty it.

Before using your HotCup™ again, carry out several boil cycles discarding the water each time.

Cleaning

Clean the exterior surface of your HotCup™ with a damp cloth and then polish it with a soft, dry cloth. Do not use steel wool pads or harsh/abrasive cleaners.

1



2



3



4

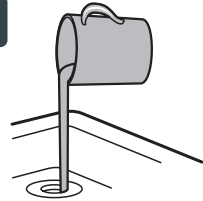

5



6

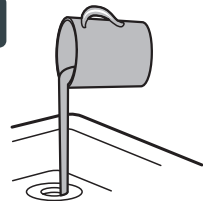

SAFETY AND EFFICIENCY

To ensure the safe and efficient operation of your HotCup™ it is important to descale it regularly. The harder your water the more regularly it will need doing. Your water company should be able to tell you how hard the water is in your area. Untreated scale deposits prevent the element conducting heat efficiently therefore wasting electricity. Scale can also cause your HotCup™ to malfunction or even cause premature failure.

Descaling using a proprietary descaling product

1. Fill your HotCup™ to the MAX fill level and place an empty cup on the drip tray. Press the start button and wait for the water to be dispensed into the cup.
2. Add a citric acid-based proprietary descaling product to the hot water in the cup and stir.
3. Tip the contents of the cup into your HotCup™ and close the lid.
4. Place the empty cup on the drip tray and press the start button.
5. Wait for the water to be dispensed into the cup.
6. Discard the water from the cup.
7. Repeat steps 4, 5 and 6 until the water level is at the MIN mark. Open the lid and empty any remaining water into the sink. Rinse your HotCup™ by filling it with clean water and emptying it into the sink (see *Emptying your HotCup™* on page 8). Fill your HotCup™ with fresh water to the MAX fill level and place an empty cup on the drip tray.
8. Press the start button and wait for the water to be dispensed into the cup.
9. Discard the water in the cup. Repeat steps 8 and 9 until the water level is at the MIN mark. Open the lid and empty any remaining water into the sink.

Descaling using vinegar or citric acid

1. You can use ordinary vinegar (white or malt) or citric acid to descale your HotCup™. Inexpensive, ordinary vinegar can be purchased in large bottles from any supermarket. Citric acid can be bought from pharmacies, home brewing/winemaking suppliers or on-line retailers.
2. If you are using vinegar, make up a solution of 1 cup of vinegar to 1 cup of water. If you are using citric acid, mix 30g of the citric acid with 500ml of water.
3. Pour the solution into your HotCup™, close the lid and allow it to stand for 1 hour.
4. Cycle your HotCup™ (as described in steps 4-6 above) until the level is at the MIN mark. Open the lid and empty any remaining solution into the sink. Rinse your HotCup™ several times by filling it with clean water and emptying it into the sink.
5. Fill your HotCup™ with fresh water to the MAX fill level and place an empty cup on the drip tray.
6. Press the start button and wait for the water to be dispensed into the cup.
7. Discard the water in the cup. Repeat steps 6 and 7 until the water level is at the MIN mark. Open the lid and empty any remaining water into the sink.
8. Finally, rinse your HotCup™ several times with clean water.

1



2



3

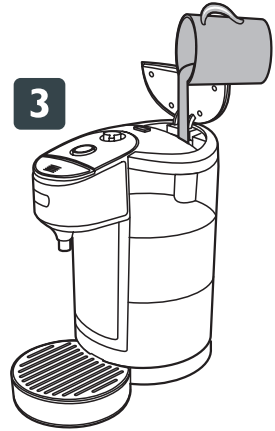

4

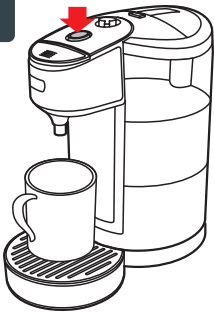

5



6

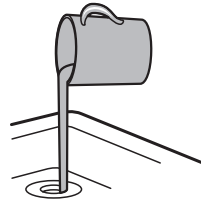

7

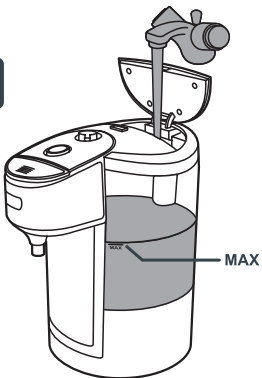

8



9

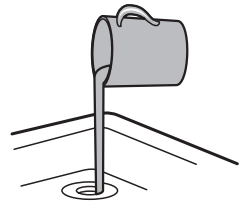

TROUBLESHOOTING

Problem	Possible Cause	Solution
The start switch will not stay in the on position.	Your HotCup™ has not reset itself after the boiling cycle.	Your HotCup™ is still too hot after the last boil cycle. Wait a few seconds for it to cool slightly before trying again.
The water tank does not illuminate and your HotCup™ does not dispense boiling water.	<ul style="list-style-type: none"> Your HotCup™ is not plugged in. Your HotCup™ is not positioned correctly on its power base. The fuse has blown. Your HotCup™ has boiled dry. 	<ul style="list-style-type: none"> Check your HotCup™ is plugged in and switched on at the supply socket. Check that the dispensing nozzle is positioned centrally over the drip tray. Check the fuse in the plug. Allow your HotCup™ to cool down completely then refill it with water.
Your HotCup™ does not dispense a full cup of water.	<ul style="list-style-type: none"> Your HotCup™ has excessive scale. The dispensing control may be set too low. 	<ul style="list-style-type: none"> Descal your HotCup™. Adjust the dispensing control.
Your HotCup™ produces excess steam but does not dispense boiling water.	<ul style="list-style-type: none"> There is not enough water in your HotCup™. Your HotCup™ has excessive scale. 	<ul style="list-style-type: none"> Fill with water up to the MAX marking then restart the boil cycle. Descal your HotCup™.
Your HotCup™ makes a noise and there is a 'clunk' sound after water has been dispensed.	This is the sound of the internal valve operating after the boil cycle finishes.	This is normal operation.
Water drips from the dispensing nozzle after the boil cycle has finished.	There is a residual amount of water left inside your HotCup™ after the boil cycle.	This is normal operation.
Steam comes out from behind the start button and behind the dispensing nozzle.	Steam is being vented in a controlled manner through designed vents.	This is normal operation.
The water reservoir is getting hot.	Hot water is being returned to the water reservoir.	This is normal operation.
Your HotCup™ immediately turns itself on when it is placed on the power base.	Your HotCup™ is already switched on.	Press the stop button.

CONNECTION TO THE MAINS SUPPLY

If the plug is not suitable for the socket outlets in your home, it can be removed and replaced by a plug of the correct type.

If the fuse in a moulded plug needs to be changed, the fuse cover must be refitted. The appliance must not be used without the fuse cover fitted.

If the plug is unsuitable, it should be dismantled and removed from the supply cord and an appropriate plug fitted as detailed. If you remove the plug it must not be connected to a 13 amp socket and the plug must be disposed of immediately.

If the terminals in the plug are not marked or if you are unsure about the installation of the plug please contact a qualified electrician.

Plug should be BS1363 approved
Fit a 13 Amp Fuse

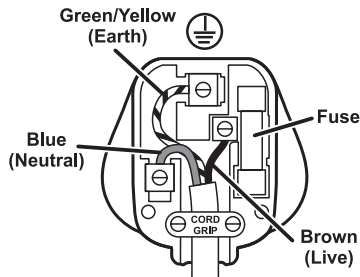

Ensure that the outer sheath of the cable
is firmly held by the clamp

TURN ON YOUR CREATIVITY™

Let the Breville® team help you turn on your creativity with a gateway to a world of food and drinks without limits. You don't have to travel far—just to your computer, tablet or mobile—where you will discover our FREE website with top tips and recipes to inspire your imagination. Join us now at:

www.turnonyourcreativity.com

Turn **on** your creativity®

AFTER SALES SERVICE

These appliances are built to the very highest of standards. There are no user serviceable parts. Follow these steps if the unit fails to operate:

Check the instructions have been followed correctly.

Check that the fuse has not blown.

Check that the mains supply is functional.

If the appliance will still not operate, return the appliance to the place it was purchased for a replacement. To return the appliance to the Customer Service Department, follow the steps below:

Pack it carefully (preferably in the original carton). Ensure the unit is clean.

Enclose your name and address and quote the model number on all correspondence.

Give the reason why you are returning it.

If within the guarantee period, state when and where it was purchased and include proof of purchase (e.g. till receipt).

Send it to our Customer Service Department at the address below:

**Customer Service Department
Jarden Consumer Solutions (Europe) Limited
Middleton Road, Royton, Oldham
OL2 5LN, UK
Telephone: 0161 621 6900 Fax: 0161 626 0391
e-mail: enquiriesEurope@jardencs.com**

GUARANTEE

Please keep your receipt as this will be required for any claims under this guarantee.

This appliance is guaranteed for 1 year after your purchase as described in this document.

During this guaranteed period, if in the unlikely event the appliance no longer functions due to a design or manufacturing fault, please take it back to the place of purchase, with your till receipt and a copy of this guarantee.

The rights and benefits under this guarantee are additional to your statutory rights, which are not affected by this guarantee. Only Jarden Consumer Solutions (Europe) Limited ("JCS (Europe)") has the right to change these terms.

JCS (Europe) undertakes within the guarantee period to repair or replace the appliance, or any part of appliance found to be not working properly free of charge provided that:

- you promptly notify the place of purchase or JCS (Europe) of the problem; and
- the appliance has not been altered in any way or subjected to damage, misuse, abuse, repair or alteration by a person other than a person authorised by JCS (Europe).

Faults that occur through, improper use, damage, abuse, use with incorrect voltage, acts of nature, events beyond the control of JCS (Europe), repair or alteration by a person other than a person authorised by JCS (Europe) or failure to follow instructions for use are not covered by this guarantee. Additionally, normal wear and tear, including, but not limited to, minor discoloration and scratches are not covered by this guarantee.

The rights under this guarantee shall only apply to the original purchaser and shall not extend to commercial or communal use.

If your appliance includes a country-specific guarantee or warranty insert please refer to the terms and conditions of such guarantee or warranty in place of this guarantee or contact your local authorized dealer for more information.

Waste electrical products should not be disposed of with household waste. Please recycle where facilities exist. E-mail us at enquiriesEurope@jardencs.com for further recycling and WEEE information.

Jarden Consumer Solutions (Europe) Limited
5400 Lakeside
Cheadle Royal Business Park
Cheadle
SK8 3GQ
UK

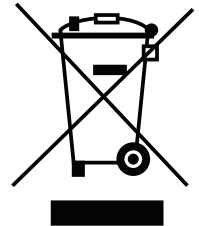

Breville®

Jarden Consumer Solutions (Europe) Limited
Cheadle Royal Business Park, Cheadle, SK8 3GQ, United Kingdom
e-mail: enquiriesEurope@jardencs.com
Telephone: 0161 621 6900

For Customer Service details, please see the website.

www.breville.co.uk

© 2015 Jarden Consumer Solutions (Europe) Limited

All rights reserved. Imported and distributed by Jarden Consumer Solutions (Europe) Limited,
Cheadle Royal Business Park, Cheadle, SK8 3GQ, United Kingdom.

The product supplied may differ slightly from the one illustrated due to continuing product development.

Printed in China